

TABLE OF CONTENTS

Description	Page Number
Table of Contents	1
Introduction	2
Question Procedure	2
Bidding Requirements	2 and 3
Award Requirements	3 and 4
Purchasing Information	4
General Terms and Conditions	
Certificate of Compliance Notice	
Insurance Requirements	
State of Missouri Wage Determination	
Purchasing Forms	4
Affidavit	
Acknowledgement of Addenda	
Exceptions	
Contractor's Utilization Plan	
Excel Spreadsheet Bid Form	
Public Works Information	5
Piper-Wind Architects Project Manual Volume 1	
Piper-Wind Architects Project Manual Volume 2	
Architects Plans	
Registered Truck Driver Ordinance	
Contractor License Requirements	
Proposed Work	5
Local Conditions Affecting Work	5
Period of Performance	5
Liquidated Damages	5
Safety Training	5
OSHA Training Requirements	5 and 6
Project Award	6
Public Works Forms	6
Equipment Questionnaire	
List of Contracts on Hand	
Annual Worker Eligibility Verification Affidavit	
List of Intended Subcontracts	
OSHA Ten Hour Training	
Sample Contract Agreement	
Public Works General Conditions	7 through 22
Public Works Special Conditions	23 through 55
Public Works Technical Specifications	56 through 85

1.0 INTRODUCTION

- 1.1 Jackson County, Missouri is seeking bids from qualified contractors for the **Construction Services for the Health Department Renovations** for the Jackson County, Missouri Public Works Department.
- 1.2 **Submission of Bids:** Bids must be submitted on-line through the Bonfire Portal at <https://jacksongov.bonfirehub.com> . Bids submitted by any other method will not be accepted.
- 1.3 **Point of Contact:** The Point of Contact for this Invitation to Bid is Barbara Casamento, Purchasing Administrator for Jackson County, Missouri.
- 1.4 **Project Location:** Jackson County, Mo. Health Department at 3651 NE Ralph Powell Road, Lee's Summit, Missouri 64064.
- 1.6 This will be Jackson County Public Works Project No. 3267.

2.0 QUESTION PROCEDURE

- 2.1 All Questions regarding this Invitation to Bid shall be communicated electronically through the Bonfire Portal via the Opportunity Q & A on the Invitation to Bid.
- 2.2 All questions must be received on the Bonfire Portal by 5:00 PM, CDT on June 1, 2022.
- 2.3 All questions will be answered in the form of Addenda to the Invitation to Bid on the Bonfire Portal.
- 2.4 There will not be any formal notification of Addenda, it is the Bidder's responsibility to check the Bonfire Portal for Addenda.
- 2.5 Bidders and their agents (including subcontractors, associates, consultants, or their agents **may not** contact any other County associate, staff or elected official regarding the matters covered by this Invitation to Bid during the solicitation and evaluation of bids.
- 2.6 Inappropriate contacts are grounds for **REJECTION OF YOUR BID.**

3.0 BIDDING REQUIREMENTS

- 3.1 Pre-Bid Meeting:
 - 3.1.1 Pre-Bid Meeting will be held on May 26, 2022 at 2:00 PM, CDT at the JCMO Health Department, 3651 NE Ralph Powell Road, Lee's Summit, Missouri 64064 on the First Floor. Attendance at the Pre-Bid Meeting is encouraged, however, if unable to attend the Pre-Bid Meeting, the building will be available for an additional walk-through.
 - 3.1.2 The additional walk through will take place on May 27, 2022 from 8 AM to 12 PM. Please call Howard Johnson, Jackson County Facility Assistant

Administrator at 816-810-1148 (mobile) or email at HJohnson@jacksongov.org to schedule an appointment. Attendees of the additional walk-through will meet on the First Floor of the building.

3.1.3 Attendance at the initial Pre-Bid Meeting or the Additional Walk-Through is **mandatory. If Bidder did not attend the Pre-Bid Meeting or the Additional Walk-Through, your Bid will be REJECTED.**

3.2 If Bidder is not located in the Greater Kansas City Metropolitan Area, bidder **MUST** provide detailed information with their bid on how the Specifications of this Invitation to Bid will be performed. Jackson County, Missouri reserves the right to determine if Bidder's plan for performance is acceptable.

3.3 State Sales Tax Exemption: Jackson County, Missouri is an exempt entity under Section 144.062, Revised Statutes of Missouri and will issue to the Successful Bidder and their subcontractors an exempt certificate. Bidders are instructed **not** to include sales tax in their prices.

3.4 Bid Bond Required:

3.4.1 Bid Bond in the amount of five percent (5%) of the total bid amount must be turned in to the Purchasing Department, Jackson County, Missouri Courthouse, 415 East 12th Street, Ground Floor, Room G-1, Kansas City, Missouri 64106 before the Response Deadline for this Invitation to Bid.

3.4.2 Bid Surety can be in the form of a Cashier's Check drawn on an acceptable bank, or a Bid Bond by a Surety Company acceptable to the Jackson County, Missouri Purchasing Department, authorized to do business in the State of Missouri and listed on the Federal Register.

3.4.3 Failure to provide a Bid Bond before the Response Deadline of this Invitation to Bid will lead to the **REJECTION OF YOUR BID.**

4.0 AWARD REQUIREMENTS

4.1 Certificate of Insurance: The Successful Bidder will be required to submit to the Purchasing Department a Certificate of Insurance meeting or exceeding the provisions of Item Fifteen of the General Conditions and Exhibit A included herein within Ten Business Days after receiving the Notification of Award. The Certificate of Insurance must be received by the Purchasing Department prior to the commencement of any work on this project.

4.2 Performance and Labor and Materials Bond Required: The Successful Bidder will be required to submit to the Purchasing Department a Performance Bond and Labor and Materials Payment Bond in the amount of 100% of the contract award within ten business days after Notification of Award. The bond must be in a form acceptable to the Director of Finance and Purchasing and executed by a Surety Company registered to do business in the State of Missouri and listed on the Federal Register. Bonds must be received by the Purchasing Department prior to the commencement of any work on this project.

- 4.3 **Maintenance Bond Required:** The Successful Bidder shall be required to submit a Maintenance Bond on the work being performed for a **Two-Year Maintenance Period**. The bond must be in a form acceptable to the Director of Finance and Purchasing, executed by a Surety Company authorized to do business in the State of Missouri and listed on the Federal Register. Successful Bidder shall submit a Maintenance Bond to Jackson County Public Works (JCPW) upon the Final Acceptance by the County.
- 4.4 **Project Exemption Certificate:** Jackson County, Missouri is an exempt entity under Section 144.062, Revised Statutes of Missouri. Upon request of the Successful Respondent, Jackson County will issue a project specific Missouri Sales Tax Exemption Certificate to the Successful Bidder and their named subcontractors to be utilized during the performance of this project. This certificate must be requested **prior to the purchase of any materials, supplies and/or equipment**. Under no circumstances will this certificate be back dated to cover materials, supplies or equipment already purchased.
- 4.5 **Compliance with Chapter 6:** The Jackson County Code for Minority, Women and Veteran Business Utilization will be required on this Invitation to Bid. The Contractor's Utilization Plan, included with Purchasing Forms as attachments herein, must be completed prior to Award. If Goals are set by Compliance, they are required, not suggested. Failure to comply will result in the REJECTION OF YOUR BID.
- 4.6 **Compliance with State Wage Determination:** Compliance with Prevailing Hourly Rate of Wages is required on any resulting contract pursuant Section 290.262 RSMo 1984 Division of Labor Standards, State of Missouri.

5.0 PURCHASING INFORMATION, INCLUDED AS SEPARATE ATTACHMENT:

General Terms and Conditions
Certificate of Compliance Notice
Insurance Requirements
State of Missouri Wage Determination

6.0 PURCHASING FORMS, INCLUDED AS A SEPARATE ATTACHMENT, TO BE DOWNLOADED, FILLED OUT AND SUBMITTED WITH YOUR BID:

Affidavit
Acknowledgement of Addenda
Exceptions
Contractor's Utilization Plan
Excel Spreadsheet Bid Form

7.0 PUBLIC WORKS INFORMATION

- 7.1 **Below are the attachments for this Invitation to Bid:**
- 7.1.1 Volume 1 Final Specifications for Health Department Renovation
 - 7.1.2 Volume 2 Final Specifications for Health Department Renovation
 - 7.1.3 Drawings for Health Department Renovations

- 7.1.4 Registered Truck Driver Ordinance
 - 7.1.5 Contractor License Requirements
 - 7.1.6 Geotechnical Report
 - 7.1.7 Phase 1 Environmental Site Assessment
- 7.2 **Proposed Work:** The Bidder shall furnish all materials, equipment, tools and labor required for interior renovations of portions of the interior of the building. Work items include ADA compliant items, associated mechanical, electrical and plumbing including all other incidental work in the most substantial and professional manner, and do everything required by the Contract Documents as defined herein.
- 7.3 **Local Conditions affecting work:** Each Bidder shall visit the site of the work and shall completely inform themselves relative to construction hazards and procedure, labor and all other conditions and factors, local and otherwise, which would affect prosecution and completion of the work and its cost. Such considerations shall include the arrangement and condition of existing structures and storage facilities, the procedure necessary for maintenance of uninterrupted operation of existing facilities for transportation, handling, and storage of materials and equipment. All such factors shall be properly investigated and considered in the preparation of bid. There will be no subsequent financial adjustment for lack of such information.
- 7.4 **Period of Performance: Time of the essence to the County on this project. The Completion Time will be One Hundred Twenty (120) Working Days excluding County holidays from the time the Notice to Proceed is issued. The Certificate of Occupancy for this Project shall be November 7, 2022.** If the Successful Bidder does not meet this deadline, then Liquidated Damages will be assessed in accordance with Special Conditions for JCPW Construction, Pages 49 through 79; SC49 LIQUIDATED DAMAGES.
- 7.5 **Liquidated Damages:** The Successful Bidder agrees that, should the bidder fail to complete the work in the time specified or such additional time as may be allowed by the engineer under the contract, the amount of liquidated damages to be recovered in accordance with Special Conditions SC-49 herein.
- 7.6 **Safety Training:** Contractors and sub-contractors who sign a contract to work on public works project provide a 10-Hour OSHA construction safety program, or similar program approved by the Department of Labor and Industrial Relations, to be completed by their on-site employees within sixty (60) days of beginning work on the construction project.
- 7.7 **OSHA Ten Hour Training Requirement:** Missouri Law, 292.675 RSMO, requires any awarded contractor and its subcontractor(s) to provide a ten-hour Occupational Safety and Health Administration (OSHA) Construction Safety Program (or a similar program approved by the Missouri Department of Labor and Industrial Relations as a qualified substitute) for their on-site employees (laborers, workmen, drivers, equipment operators, and craftsmen) who have not previously completed such a program and are directly engaged in actual construction of the improvement (or working at a nearby or adjacent facility used for construction of the improvement). The awarded contractor and its subcontractor(s) shall require all such employees to complete this ten-hour program,

pursuant to 292.675 RSMO, unless they hold documentation on their prior completion of said program. Penalties, for Non-Compliance include contractor forfeiture to the Contracting Authority in the amount of \$2,500, plus \$100 per contractor and subcontractor employee for each calendar day such employee is employed beyond the elapsed time period for required program completion under 292.675 RSMO.

7.8 **Project Award:** This project will be awarded to the lowest, responsive, responsible Bidder.

8.0 PUBLIC WORKS FORMS, INCLUDED AS A SEPARATE ATTACHMENT, TO BE DOWNLOADED, FILLED OUT AND SUBMITTED WITH YOUR BID:

Equipment Questionnaire
List of Contacts on Hand
Annual Worker Eligibility Verification Affidavit
List of Intended Subcontractors
OHSA Ten Hour Trainee Affidavit
Proposed Contract Agreement

PUBLIC WORKS GENERAL CONDITIONS

GC-3 DEFINITIONS

Any word, phrase, or other expression defined in this paragraph GC-3 and used in these Contract Documents shall have the meaning herein given:

- a. "Contract" or "Contract Documents" shall include all of the documents and drawings Included in this Invitation to Bid.
- b. "Owner" shall mean the corporation (municipal or otherwise), board, district, or other political subdivision, company, or firm, who is named and designated as the "Party of the First Part" in the Contract Agreement hereto attached and for whom the work covered by this Contract is to be performed, acting through its duly authorized officers or agents."
- c. "Contractor" shall mean the corporation, company, partnership, firm, or individual, named and designated in the Contract Agreement as the "Party of the Second Part" and who has entered into this Contract for the performance of the work covered thereby, and its, his, or their duly authorized agents and other legal representatives.
- d. "Engineer-Architect" or "A-E" shall mean the Director of the Jackson County Public Works Department, or authorized agent.
- e. "Inspector" shall mean the engineering, architectural or technical inspector or inspectors duly authorized by the Owner or Engineer-Architect, limited in each case to the particular duties entrusted to them.
- f. "Date of Contract" or words equivalent thereto shall mean the date written in the first paragraph of the Contract Agreement.
- g. "Day" or "days" unless herein otherwise expressly defined shall mean a calendar day or days of 24-hours each.
- h. "The Work" shall mean the work to be done and the equipment, supplies, and materials to be furnished under this Contract, unless some other meaning is indicated by the context.
- i. "Plans" or "the plans" or "the Contract Plans" shall mean and include all:
 - (1) Drawings caused by the Owner for this Invitation to Bid.
 - (2) All drawings submitted by the successful bidder with their proposal and by the Contractor to the Owner, when and as approved by the Engineer-Architect and
 - (3) All drawings submitted by the Owner or Engineer-Architect to the Contractor during the progress of the work as provided for herein.
- j. Whenever in these Contract Documents the words "as ordered," "as directed," "as required," "as permitted," "as allowed," or words or phrases of like import are used, it shall be understood that the order, direction, requirement, permission or allowance of the Owner and Engineer-Architect is intended.
- k. Similarly, the words "approved," "reasonable," "suitable," "acceptable," "properly," "satisfactory," or words of like effect and import, unless otherwise particularly Ispecified herein, shall mean approved, reasonable, suitable, acceptable, proper, or satisfactory in the judgment of the Owner and Engineer-Architect.
- l. Whenever any statement is made in the Contract Documents concerning the expression "it is understood and agreed," or an expression of like import, such expression means the mutual understanding agreement of the parties executing the Contract Agreement of which these general conditions are a part.

GC-4 VERBAL STATEMENTS NOT BINDING

It is understood and agreed that the written terms and provisions of this agreement shall supersede all prior verbal statements of any and every official and/or other representative of the Owner, and such statements shall not be effective or be construed as entering into, or forming a part of, or altering in any way whatsoever, the written agreement.

GC-5 TITLES AND SUBHEADINGS

The titles or subheadings used in this Contract and on the Plans and drawings and in the technical specifications, are understood to be for convenience of reference only, and shall not be taken or considered as being a part thereof, or as having any bearing on the interpretation thereof.

GC-6 COPIES OF CONTRACT

The Contractor's Bid as submitted, Bond Form(s), and the Contract Agreement shall be prepared. Five (5) of these copies, each containing the Bond (or Bonds) properly executed and the Contract Agreement signed by the Contractor, shall be submitted to and signed by the Owner; two (2) of the copies so signed shall be delivered to the Contractor—one (1) for their surety company and one (1) to the Engineer-Architect. Two (2) copies shall remain with the Owner.

GC-7 SCOPE, NATURE, AND INTENT OF TECHNICAL SPECIFICATIONS AND PLANS

The said Technical Specifications and Plans are intended to supplement, but not necessarily duplicate each other, and together constitute one complete set of technical specifications and plans, so that any work exhibited in the one and not in the other, shall be executed just as if it had been set forth in both, in order that the work shall be completed according to the complete design or designs as decided and determined by the Engineer-Architect. Should anything be omitted from the technical specifications and plans which is necessary to clear understanding of the work, or should it appear various instructions are in conflict, then the Contractor shall secure written instructions from the Engineer-Architect before proceeding with the construction affected by such omissions or discrepancies. It is understood and agreed that the work shall be performed and completed according to the true spirit, meaning, and intent of the Contract, Technical Specifications and Plans. The Contractor's responsibility for construction covered by conflicting requirements, not provided for by addendum prior to the time of opening bids for the work represented thereby shall not extend beyond the construction in conformity with the cheaper of the said conflicting requirements. Any increase in cost of work required to be done in excess of the cheaper of the conflicting requirement will be paid for as extra work as provided for herein.

GC-8 FIGURED DIMENSIONS TO GOVERN

Dimensions and elevations shown on the plans shall be accurately followed, even though they differ from scaled measurements. No work shown on the plans, the dimensions of which are not indicated, shall be executed until the required dimensions have been obtained from the Engineer-Architect.

GC-9 CONTRACTOR TO CHECK PLANS AND SCHEDULES

The Contractor shall check all dimensions, elevations, and quantities shown on the Plans, and schedules given to them by the Engineer-Architect and shall notify the Engineer-Architect of any discrepancy between the Plans and the conditions on the ground, or any error or omission in Plans, or in the layout as given by stakes, points, or instructions, which they may discover in the course of the work. The Contractor will not be allowed to take advantage of any error or omission in the Plans or Contract Documents, as full instructions will be furnished by the Engineer-Architect should such error or omission be discovered, and the Contractor shall carry out such instructions as if originally specified.



GC-10 DRAWINGS TO BE FURNISHED BY CONTRACTOR

The Contractor shall check and verify all field measurements and shall furnish/ all shop, fabrication, assembly, and other drawings required by the technical specifications; drawings of equipment and devices, offered by the Contractor for approval of the Engineer-Architect, in sufficient detail to adequately show the construction and operation thereof; drawings showing essential details of any changes in design of construction proposed, for consideration of the Owner, by the Contractor in lieu of the design or arrangement required by the Contract or any item of extra work thereunder; and all required special wiring and piping layouts. Not less than three (3) preliminary copies of each such drawing shall be submitted to the Engineer-Architect for their check and approval, together with the same number of copies of each drawing required by the Engineer-Architect to be revised. On final approval, the Engineer-Architect shall be furnished with a total of not less than two (2) copies, and more when required, of each drawing as finally approved; such number to include any copies of preliminary or revised drawings which are approved as submitted. After due approval by the Engineer-Architect, all such drawings shall become a part of the Contract Documents and the work or equipment shown thereby shall be in conformity

Contract Documents and the work or equipment shown thereby shall be in conformity therewith unless required by the Owner. No work shall be performed in connection with the fabrication or manufacture of material or equipment shown by any drawing thereof, nor shall any accessory, appurtenance, or device not fabricated or manufactured by the Contractor or their subcontractor, be purchased until the drawing or drawings therefor have been approved as stipulated, except at the Contractor's own risk and responsibility. The Engineer- Architect's check and approval of drawings submitted by the Contractor will be for, and will cover, only general conformity to the Plans and technical specifications and will not constitute a blanket approval of all dimensions, quantities, and details of the material Or equipment shown nor shall such relieve the Contractor of their responsibility for errors contained in such drawings.

GC-11 APPROVED EQUAL

If the Contractor desires to substitute materials, appliances, equipment, etc., specified in the technical specifications, the Contractor shall request, in writing, an approval from the Engineer-Architect. Said materials; appliances, equipment, etc. can only be used as approved equal after receipt from the Engineer-Architect of written approval thereof. If the Engineer-Architect is not familiar with the products for which the Contractor desires approval as an equal, they will reserve the right to have the products submitted to an independent testing laboratory of their choosing, to determine if the substitute product is an equal. The costs of such tests shall be borne by the Contractor or the parties offering the product as an approved equal.

GC-12 OWNERSHIP OF DRAWINGS

All drawings, technical specifications and copies thereof furnished by the Engineer-Architect are their property. They are not to be used on other work, and, with the exception of the signed contract set, are to be returned to them on request, at the completion of the work.

GC-13 SAMPLES

The Contractor shall furnish for approval, with such promptness as to cause no delay in their own work or in that of any other Contractor, all samples as directed by the Engineer-Architect. The Engineer-Architect shall check and approve such samples, with reasonable promptness, only for conformance with the design concept of the project and for compliance with the information given in the Contract Documents. The work shall be in accordance with approved samples.



GC-14 CONTRACTOR TO FURNISH STAKES AND HELP

When the documents or technical specifications require that the Engineer-Architect perform staking, the Contractor shall furnish without charge, competent employees from their force and such tools, stakes, and other materials as the Engineer-Architect may require for the proper staking out of the work, and in making measurements and surveys, and in establishing temporary or permanent reference marks in connection with said work the Contractor shall perform all work necessary to locate all construction on the site for building projects. A registered land surveyor employed by the Contractor shall locate the building corners.

GC-15 LINES AND GRADES

All work done under this Contract shall be done to the lines, grades, and elevations shown on the Plans. The Contractor shall keep the Engineer-Architect informed, a reasonable time in advance, of the times and places at which they wish to do work, in order that lines and grades may be furnished and necessary measurements for record and payment may be made with the minimum of inconvenience to the Engineer-Architect and of delay to the Contractor. This paragraph applies to projects for which the Engineer-Architect is to make staking surveys and payment is on a unit price basis.

GC-16 WORK DONE WITHOUT LINES OR GRADES

Any work done without being properly located and established by base lines, offset stakes, bench marks, or other basic reference points located, established, or checked by the Engineer-Architect, may be ordered removed and replaced at the Contractor's cost and expense.

GC-17 PRESERVATION OF MONUMENTS AND STAKES

The Contractor shall carefully preserve all monuments, bench marks, reference points, and stakes, and in case of willful or careless destruction of the same will be charged with the resulting expense of replacement. The Contractor shall have no claim for damages or extension of time due to such destruction. In case of any permanent monuments, bench marks, section corner and quarter-section corner monuments which must be removed or disturbed during construction, the Contractor shall carefully protect and preserve the same until they have properly referenced for relocation and replacement. The Contractor shall furnish, at their own expenses, a duly qualified and Missouri licensed land surveyor to reference and reestablish, after completion of construction, with permanent markers as is normally used in these locations. The Contractor shall also furnish a certificate sealed by the land surveyor with a statement that the monument recovered was reset in the same location prior to final acceptance of the project by the Owner.

GC-19 CONTRACTOR'S OFFICE AT SITE OF WORK

During the performance of this Contract, the Contractor shall maintain a suitable office at or near the site of the work which shall be the headquarters of a representative authorized to receive drawings, instructions, or other communications or articles from the Owner or the Owner's agents; and any such communications given to the said representative, or delivered at the Contractor's office at the site of the work in their absence, shall be deemed to have been given to the Contractor.

GC-20 RESPONSIBILITY OF CONTRACTOR

The Contractor shall furnish all transportation, tools, equipment, machinery, and plant, and all suitable appliances, requisite for the execution of this Contract and shall be solely answerable for the same and for the safe, proper, and lawful construction, maintenance, and use thereof. They shall cover and protect their work from damage, and all injury to the same (before the completion and acceptance of this contract) shall be made good by them. The Contractor shall be solely answerable for all damage to the Owner or the property of the Owner, to other contractors or other employees of the Owner, to the neighboring premises, or to any private or personal property, due to improper, illegal, or negligent conduct of theirs or their subcontractors, employees, or agents in and about said work, or in the execution of the work covered by this Contract, or any extra work undertaken as herein provided, or to

any defect in, or the improper use of, any scaffolding, shoring, apparatus, ways, works, machinery, or plant.

GC-23 RELATIONS WITH OTHER CONTRACTORS

The Contractor shall cooperate with all other contractors who may be performing work on behalf of the Owner, and workmen who may be employed by the Owner, on any work in the vicinity of the work to be done under this Contract, and they shall so conduct their operations as to interfere to the least possible extent with the work of such contractors or employees. The Contractor shall promptly make good, at their own expense, any injury or damage that may be sustained by other contractors or employees of the owner at their hands. Any difference or conflict which may arise between the Contractor and other contractors or between the Contractor and the employees of the Owner, in regard to their work shall be adjusted and determined by the Engineer-Architect. If the work of the Contractor is delayed because of any acts or omissions of any other contractor or contractors, the Contractor shall have no claim against the Owner on that account other than for an extension of time. When two or more contracts are being executed at one time in such a manner that work on one contract may interfere with that of another, the Engineer-Architect shall decide which contractor shall cease work and which shall continue, or whether the work on both contracts shall progress at the same time, and in what manner. When the territory of one contract is the necessary or convenient means of access for the transportation or movement of employees, materials, or appliances required for the execution of another contract, such privileges of access or any other reasonable privilege may be granted by the Engineer-Architect to the Contractor so desiring, to the extent and amount, in the manner, and at the time, which may be reasonably necessary.

GC-24 DEFENSE OF SUITS

In case any action at law or suit in equity is brought against the Owner or any of its officers or agents for or on account of the failure, omission, or neglect of the Contractor to do and perform any of the covenants, acts, matters, or things by this Contract undertaken to be done or performed, or for any injury or damage caused by the negligence or alleged negligence, of the Contractor or their subcontractors, or their employees or agents, the Contractor shall indemnify and save harmless the Owner, and officers and agents of the Owner, of and from all losses, costs, damages, expenses, judgments, or decrees whatever arising out of such actions or suits as may be brought as aforesaid.

GC-25 METHODS OF OPERATION

The Contractor shall give to the Engineer-Architect full information in advance as to their Plans for carrying on any part of the work. If at any time before the beginning or during the progress of the work, any part of the Contractor's plant or equipment or any of their methods of executing the work, appear to the Engineer-Architect to be unsafe, inefficient, or inadequate to ensure the required quality, or rate of progress, of the work, they may order the Contractor to increase or improve their facilities or methods, and the Contractor shall promptly comply with such orders, but neither compliance with such orders nor failure of the Engineer-Architect to issue such orders shall relieve the Contractor from their obligations to secure the degree of safety, the quality of work, and the rate of progress required by this Contract. The Contractor alone shall be responsible for the safety, adequacy, and efficiency of their plant, equipment, and methods. The approval by the Engineer-Architect of any plan or method of work proposed by the Contractor shall not relieve the Contractor of any responsibility therefor, and such approval shall not be considered as an assumption by the Owner, or any officer, agent, or employee thereof, of any risk or liability, and the Contractor shall have no claim under this Contract on account of the failure or inefficiency of any plan or method so approved. Such approval shall be considered, and shall mean that the Engineer-Architect has no objection to the Contractor's use or adoption, at their risk and responsibility, of the plan or method so proposed by the Contractor.



GC-26 SUGGESTION TO CONTRACTOR ADOPTED AT HIS OWN RISK

Any plan or method of work suggested by the Engineer-Architect, or other representative of the Owner, to the Contractor, but not specified or required, if adopted or followed by the Contractor in whole or in part, shall be used at the risk and responsibility of the Contractor, and the Engineer-Architect and the Owner will assume no responsibility therefor.

GC-27 AUTHORITY AND DUTY OF THE ENGINEER-ARCHITECT

It is mutually agreed by and between the parties to this Contract, that the Engineer-Architect shall inspect all work included herein. In order to prevent delays and disputes and to discourage litigation, it is further agreed by and between the parties to this Contract that the Engineer-Architect shall in all cases determine the amounts and quantities of the several kinds of work which are to be paid for under this Contract; that they shall determine all questions in relation to said work and the construction thereof; that they shall in all cases decide every question which may arise relative to the execution of this Contract on the part of said Contractor; that their decisions and findings shall be the conditions precedent to the right, of the parties hereto, to any action on the Contract, and to any rights of the Contractor to receive any money under this Contract provided, however, that should the Engineer-Architect render any decision or give any directions which, in the opinion of the Contractor, is not in accordance with the meaning and intent of this Contract, the Contractor may file with the Engineer-Architect within thirty (30) days, their written objection to the decision or direction so rendered. It is the intent of this agreement that there shall be no delay in the execution of the work, and the decision or directions of the Engineer-Architect as rendered shall be promptly carried out.

GC-28 INSPECTION

It is agreed by the Contractor that the Owner shall be and is hereby authorized to appoint or employ (either directly or through the Engineer-Architect) such architects, engineers, and inspectors as the Owner may deem proper, to inspect the materials furnished and the work performed under this Contract, and to see that the said materials are furnished, and the said work performed, in accordance with the Plans and technical specifications therefore. The Contractor shall furnish all reasonable aid and assistance required by the Engineer-Architect, or by the inspectors, for the proper inspection and examination of the work and all parts thereof. The Contractor shall regard and obey the directions and instructions of the Engineer-Architect, or any inspector so appointed, when the same are consistent with the obligations of this Contract and the Technical Specifications therefore, provided, however, that should the Contractor object to any order given by any subordinate architect, engineer, or inspector, the Contractor may make written appeal to the Engineer-Architect for their decision. Architects, engineers, inspectors and other properly authorized representatives of the Owner or Engineer-Architect shall be free at all times to perform their duties, and intimidation or attempted intimidation of any one of them by the Contractor or by any of their employees shall be sufficient reason, if the Owner so decides, to annul the Contract. Such inspection shall not relieve the Contractor from any obligation to perform said work strictly in accordance with the Plans and technical specifications or any modifications thereof as herein provided, and work not so constructed shall be removed and made good by the Contractor at their own expense, and free of all expenses to the Owner, whenever so ordered by the Engineer-Architect, without reference to any previous oversight or error in inspection. The Engineer-Architect does not assume any responsibility for work or action of the Contractor.

If work on any project is subject to the approval of the Federal Highway Administration, representatives of the Missouri Highways and Transportation Commission and the Federal Highway Administration shall have access to the project for the purpose of inspecting and reviewing work being performed by any contractor or subcontractor on the project. Contractors and subcontractors shall maintain books, account, ledgers, invoices, drafts, documents, pages, and other business records pertaining to the performance of this project and shall require that such materials be available at the Contractor's field or permanent business offices at all reasonable times during the performance of the Contract and for

three years from date of final FHWA voucher acceptance under the Contract, for inspection by authorized representatives of the Commission and/or the Federal Highway Administration.

GC-29 NO WAIVER OF RIGHTS

Neither the inspection by the Owner or any of the owner's officials, employees, or agents, nor any order by the owner for payment of money, nor any payment for, or acceptance of, the whole or any part of the work by the Owner or Engineer-Architect, nor any extension of time, nor any possession taken by the Owner or its employees, shall operate as a waiver of any provision of this Contract, or of any power herein reserved to the Owner, or any right to damages herein provided, or shall any waiver of any breach in this Contract be held to be a waiver of any other or subsequent breach.

GC-30 SUPERINTENDENCE OF WORK

The Contractor shall provide and maintain, continually on the site of the work during its progress, adequate and competent superintendent of all operations for and in connection with the work being performed under this Contract, either personal or by a duly authorized superintendent or other representative. The superintendent or other representative of the Contractor on the work, and who has charge thereof, shall be fully authorized to act for the Contractor and to receive whatever orders as may be given for the proper prosecution of the work, or notices in connection therewith.

GC-31 ORDERS TO CONTRACTOR'S AGENT

Whenever the Contractor is not present on any part of work where it may be desired to give directions, orders may be given by the Engineer-Architect or his representative, to, and shall be received and obeyed by, the superintendent or foreman who may have charge of the particular part of the work in reference to which such orders are given.

GC-32 PROTECTION OF PROPERTY AND PUBLIC LIABILITY

The Contractor shall assume full responsibility for the protection of all public and private property, structures, sewers, and utilities, both above and below ground, along, beneath, above, across, or near the site or sites of the work being performed under this Contract, or which are in any manner affected by the prosecution of the work or the transportation of employees or materials in connection therewith. Barriers shall be kept placed at all times to protect persons other than those engaged on or about the work from accident, and the Contractor will be held responsible for all accidents to persons or property through any negligence of themselves or their employees. The Contractor shall indemnify, defend, and save harmless the Owner against all damages to such property, structures, and utilities, together with all claims for damages for personal injury, including accidental death, arising out of their operations in connection with this Contract. All property so damaged shall be repaired or replaced to a condition equal to its condition immediately prior to the time of damage, and to the satisfaction of the owner thereof. The Contractor shall give reasonable notice to the owner or owners of public or private property and utilities when such property is liable to injury or damage through the performance of the work, and shall make all necessary arrangements with such owner or owners relative to the removal and replacement or protection of such property or utilities. All permits and licenses required in the prosecution of any and all parts of the work shall be obtained and paid for by the Contractor. The Contractor shall satisfactorily shore, support, and protect any and all structures, and all pipes, sewers, drains, conduits, and other facilities, and shall be responsible for any damage resulting thereto. The Contractor shall not be entitled to any damages or extra pay on account of any postponement, interference, or delay caused by any such structures and facilities being on the line of the work, whether they are shown on the Plans or not.



GC-34 MODIFICATIONS AND ALTERATIONS

In executing the Contract Agreement, the Contractor agrees that the Owner shall have the right to make such modifications, changes, and alterations, as the Owner may see fit, in the line, grade, form, arrangements, dimensions, extent, or plan, of the work agreed to be done or any part thereof, or in the materials to be used therein, either before or after the beginning of construction thereof, without affecting the validity of the Contract and the performance, payment, and maintenance bond contained therein. Where any modification, change, or alteration increases the quantity of work to be performed and is within the scope of a fair interpretation thereof, such increase shall be paid for according to the quantity of the work actually done, either at unit prices included in the Contract, or, in the absence of such unit prices, as extra work. Modifications and alterations, which reduce the quantity of work to be done, shall not constitute a claim for damages or for anticipated profits on work involved in such reduction. The Engineer-Architect shall determine, on an equitable basis, the amount of:

- a. Credit due the Owner for Contract work not performed, as a result of modifications or alterations authorized hereunder, where the value of the omitted work is not fixed by unit prices in the Contract.
- b. Allowance to the Contractor for any actual loss incurred in connection with the purchase, delivery, and subsequent disposal of materials and equipment required for use on the work as originally planned but which could not be used in any part of the work as actually built.
- c. Any other adjustment of the contract amount where the method to be used in making such adjustment is not clearly defined in the Contract Documents. All orders for modifications, changes, or alterations in the work as herein provided shall be in writing, either by the Engineer-Architect under the authority of the Owner or by the Owner directly.

GC-35 EXTRA WORK

The term "extra work" as used in this Contract, shall be understood to mean and to include all work that may be required by the Engineer-Architect or Owner to be performed by the Contractor to accomplish any change or alterations in, or addition to, the work shown by the Plans, or required or reasonably implied by the technical specifications, which is not covered by the proposal and not otherwise provided under "Modifications and Alterations" herein. It is agreed that the Contractor shall perform all extra work under the direction of the Engineer-Architect, when and as so ordered in writing by the Engineer-Architect or Owner. When such extra work is ordered, it shall be paid for either by a lump sum or by unit prices mutually agreed upon by the Owner and Contractor in writing, or if such agreement cannot be made, on a force account basis, to be compensated in the following manner:

- a. Labor. For all labor and foreman in direct charge of the specific operations, the Contractor shall receive the rate of wage (or scale) agreed upon in writing before beginning work for each and every hour that said labor and foreman are actually engaged in such work. The Contractor shall receive the actual costs paid to, or in behalf of, employees by reason of subsistence and travel allowances, health and welfare benefits, pension fund benefits or other benefits, when such amounts are required by collective bargaining agreement or other employment contract generally applicable to the classes of labor employed on the work.
An amount equal to twenty percent (20%) of the sum of the above items will also be paid the Contractor.
- b. Bond Insurance and Tax. For property damage, liability, and workmen's compensation insurance premiums, unemployment insurance contributions and social security taxes on the force account work, the Contractor shall receive the actual cost, to which cost six percent will be added. The Contractor shall furnish satisfactory evidence of the rates paid for such bond, insurance, and tax.

- c. **Materials.** For materials accepted by the Engineer-Architect and used, the Contractor shall receive the actual cost of such materials delivered on the work, including transportation charges paid by him (exclusive of machinery rentals as hereinafter set forth), to which cost 15 percent will be added.
- d. **Equipment.** For any machinery or special equipment (other than small tools) including fuel and lubricants, plus transportation costs, the use of which has been authorized by the Engineer-Architect, the Contractor shall receive the rental rates agreed upon in writing before such work is begun for the actual time that such equipment is in operation on the work, to which rental sum fifteen percent (15%) will be added.
- e. **Miscellaneous.** No additional allowance will be made for general superintendent, the use of small tools, or other costs for which no specific allowance is herein provided.
- f. **Compensation.** The Contractor's representative and the Engineer-Architect shall compare records of the cost of work done as ordered on a force account basis.
- g. **Statements.** No payment will be made for work performed on a force account basis until the Contractor has furnished the Engineer-Architect with duplicate itemized statements of the cost of such force account work detailed as follows:
 - (1) Name, classification, date, daily hours, total hours rate, and extension for each laborer and foreman.
 - (2) Designation, dates, daily hours, total hours, rental rate, and extension for each unit of machinery and equipment.
 - (3) Quantities of materials, prices, and extensions.
 - (4) Transportation of materials.
 - (5) Cost of property damage, liability and workmen's compensation insurance premiums, unemployment insurance contributions, and social security tax.
 - (6) Statements shall be accompanied and supported by received invoices for all materials used and transportation charges. However, if materials used on the force account work are not specifically purchased for such work but are taken from the Contractor's stock, then in lieu of the invoices the Contractor shall furnish an affidavit certifying that such materials were taken from their stock, that the quantity claimed was actually used, and that the price and transportation claimed represent the actual cost to the Contractor.The Contractor shall not begin any work for which price payments under classifications are not provided in the contract without first bringing the matter to the attention of the Engineer-Architect and no bills or charges for "Extra Work" will be allowed except for that ordered in writing before its execution.

GC-36 PROVISION FOR EMERGENCIES

Whenever, in the opinion of the Engineer-Architect, the Contractor has not taken sufficient precaution for the safety of the public or the protection of the work to be constructed under this contract, or of adjacent structures or property which may be injured by processes of construction on account of such neglect, and whenever, in the opinion of the Engineer-Architect, an emergency shall arise and immediate action shall be considered necessary in order to protect public or private, personal or property interests, then the Engineer-Architect, with or without notice to the Contractor, may provide suitable protection to the said interests by causing such work to be done and material to be furnished and placed as the Engineer-Architect may consider necessary and adequate. The cost and expense of such work and materials so furnished shall be borne by the Contractor, and, if the same shall not be paid on presentation of the bills therefore, such costs shall be deducted from any amounts due (or to become due) the Contractor. The performance of such emergency work under the direction of the Engineer-Architect shall in no way relieve the Contractor of responsibility for damages which may occur during or after such precaution has been duly taken by the Engineer-Architect.

GC-38 RIGHT OF OWNER TO TERMINATE CONTRACT

If the work to be done under this Contract shall be abandoned by the Contractor; or if this Contract shall be assigned by them otherwise than as herein provided; or if the Contractor should be adjudged a bankrupt, or if a general assignment of their assets be made for the benefit of their creditors, or if a receiver should be appointed for the Contractor or any of their property; or if at any time the Engineer-Architect shall certify in writing to the Owner that the performance of the work under this Contract is being unnecessarily delayed, or that the Contractor is willfully violating any of the conditions or covenants of this Contract or the technical specifications therefore, or that they are executing the same in bad faith or otherwise not in accordance with the terms of said Contract, or if the work be not substantially completed within the time to which such completion date may be extended; then the Owner may serve written notice upon the Contractor and their surety of said Owner's intention to terminate this Contract, and, unless within five (5) days after the serving of such notice upon the Contractor, a satisfactory arrangement be made for the continuance thereof, this Contract shall cease and terminate. In the event of such termination, the Owner shall immediately serve notice thereof upon the surety and the Contractor, and the surety shall have the right to take over and complete the work, provided, however, that if the surety does not commence performance thereof within thirty (30) days from the date of said notice of termination, the Owner may take over the work and prosecute same to completion, by Contract or otherwise, for the account of the Contractor. The Contractor and their surety shall be liable to the Owner for any and all excess cost sustained by the Owner by reason of such prosecution and completion including compensation for additional architectural, engineering, managerial and administrative expense; and in such event the Owner may take possession of, and utilize in completing the Work, all such materials, equipment, tools, and plant as may be on the site of the work and necessary therefore.

GC-39 SUSPENSION OF WORK ON NOTICE

The Contractor shall delay or suspend the progress of the Work or any part thereof, whenever they shall be so required by verbal order of the Owner or Engineer-Architect at the moment it is issued. Said verbal order will be confirmed by written order at the request of the Contractor which shall note the time the verbal order was issued. The Contractor shall delay or suspend the progress for such periods of time as required to comply with directions issued by Owner or Engineer-Architect, provided that, in the event such delay or suspension of the progress of the Work, or any part thereof, the time for completion of the Work so suspended or delayed by such suspensions shall be extended for a period equivalent to the time lost; however, such order of the Owner or Engineer-Architect shall not otherwise modify or invalidate any of the provisions of this Contract. In the event that the work shall be stopped by order of the Owner or Engineer-Architect, any expense which, in the opinion and judgment of the Engineer-Architect, is caused thereby shall be paid by the Owner to the Contractor.

GC-40 LOSSES FROM NATURAL CAUSES

All loss or damage arising out of the nature of the work to be done, or from the action of the elements, or from floods or overflows, or from ground water, or from unusual obstructions or difficulties, or any other natural or existing circumstance either known or unforeseen, which may be encountered in the prosecution of the said work shall be sustained and borne by the Contractor at their own cost and expense.

GC-41 LAWS AND ORDINANCES

The Contractor shall keep themselves fully informed of all existing and current regulations of the Owner and County, State and National laws which in any way limit or control the actions or operations of those engaged upon the work or affecting the materials supplied to or by them. The Contractor shall at all times observe and comply with all ordinances, laws, and regulations, and shall protect and indemnify



the Owner and the Owner's officers and agents against any claims or liability arising from or based on any violation of the same.

GC-42 SANITARY REGULATIONS

In general, the operations of the Contractor shall be in full conformity with all of the rules and regulations of boards and bodies having jurisdiction with respect to sanitation. The Contractor shall supply safe and sufficient drinking water to all of their employees. The Contractor shall obey and enforce all sanitary regulations and orders, and shall take precautions against infectious diseases and the spread of same.

GC-43 CHARACTER OF EMPLOYEES

The Contractor shall employ only employees, who are competent to perform the work assigned to them and (in the case of skilled labor), who are adequately trained and experienced in their respective trades and who do satisfactory work. In all cases, local labor shall be given preference when available. Whenever the Engineer-Architect shall notify the Contractor that any employee on the work is, in their opinion, incompetent, unfaithful, or disorderly, or who uses threatening or abusive language when on the work to any person representing the Owner, such employee shall be immediately discharged from the work and shall not be reemploy thereon except with the consent of the Engineer-Architect.

GC-44 SATURDAY, SUNDAY, HOLIDAY, AND NIGHT WORK

No work shall be done between the hours of 6:00 p.m. and 8:00 a.m., nor on Saturdays, Sundays, or legal holidays, without the written approval or permission of the Engineer-Architect in each case, except such work as may be necessary for proper care, maintenance, and protection of work already done or equipment, or in the case of an emergency. The Contractor may establish night work as a regular procedure, with the written permission of the Engineer-Architect. The Engineer-Architect, however, may revoke such permission, at any time if the Contractor fails to maintain at night, adequate equipment for the proper prosecution and control of the work, and all operations performed thereunder.

GC-45 UNFAVORABLE CONSTRUCTION CONDITIONS

During unfavorable weather, wet ground, or other unsuitable construction condition, the Contractor shall confine their operations to work, which will not be affected adversely thereby. No portion of the work shall be constructed under conditions, which would affect adversely the quality of efficiency thereof unless, by special means or precautions approved by the Engineer-Architect, the Contractor shall be able to perform the work in a proper and satisfactory manner.

GC-46 BEGINNING, PROGRESS, AND TIME OF COMPLETION OF WORK

The Contractor shall, within ten (10) days after being instructed to do so in a written notice from the Owner, commence the work to be done under this Contract; and the rate of progress shall be such that the work shall have been completed in accordance with the terms of the Contract on or before the termination of the construction period named in the bid, subject to any extension or extensions of such time made as hereinafter provided. The Contractor may be required to furnish the Engineer-Architect with a tentative schedule setting forth in detail the procedure they propose to follow, and giving the dates on which they expect to start and to complete separate portions of the work. If at any time, in the opinion of the Engineer-Architect, proper progress is not being maintained, such changes shall be made in the schedule of operations as the Engineer-Architect shall direct or approve.

GC-47 HINDRANCES AND DELAYS

In executing the Contract Agreement, the Contractor expressly covenants and agrees that, in undertaking to complete the work within the time therein fixed, they have taken into consideration and made allowances for all hindrances and delays incident to such work, whether growing out of delays in



securing materials or employees or otherwise. The Contractor shall make no charge for hindrances or delays from any cause during the progress of the work, or any portion thereof, embraced in this Contract, except as provided in "GC-39 Suspension of Work on Notice".

GC-48 EXTENSION OF TIME

Should the Contractor be delayed in the final completion of the Work by any act or neglect of the Owner or Engineer-Architect, or of any employee of either, or by any other Contractor employed by the Owner, or by strikes, fire, or other cause or causes outside of and beyond the control of the Contractor and which could have been neither anticipated nor avoided, then an extension of time sufficient to compensate for the delay shall be granted by the Owner provided, however, that the Contractor shall give the Owner, and the Engineer-Architect, within ten (10) consecutive days from the start of such delay, notice in writing of the cause of delay in each case. Extensions of time will not be granted for delays caused by unfavorable weather, unsuitable ground conditions, inadequate construction force, or the failure of the Contractor to place orders for equipment or materials a sufficient time in advance to ensure delivery when needed.

GC-49 LIQUIDATED DAMAGES

It is mutually understood and agreed by and between the parties to this Contract, in signing the agreement thereof, that time is of the essence of this Contract, and that in the event that the said Contractor shall fail in the performance of the work specified and required to be performed within the period of time stipulated therefor in the Contract agreement binding said parties, after due allowance for any extension or extensions of time which may be granted under the provisions of the preceding paragraph, the said Contractor shall pay unto the said Owner, as stipulated liquidated damages and not as a penalty, the sum indicated in the Special Conditions for each and every calendar day that the Contractor shall be in default. In case of joint responsibility for any delay in the final completion of the work covered by this Contract, where two or more separate contracts are in force at the same time and cover work on the same project and at the same site, the total amount of liquidated damages assessed against all contractors under such contracts, for any one (1) day of delay in the final completion of the work, will not be greater than the amount listed in Special Conditions, and the amount assessed against any one Contractor for one (1) day of delay will be based upon the individual responsibility of such Contractor for the aforesaid delay as determined by, and in judgment of the Owner. The Owner shall have the right to deduct said liquidated damages from any moneys in its hands, otherwise due, or to become due, to said Contractor, or to sue for and recover compensation for damage for nonperformance of this Contract at the time stipulated herein and provided for.

GC-50 TESTS OF MATERIALS OFFERED BY CONTRACTOR

All specified and required tests for approval of source of materials shall be made at the expense of the Contractor by a properly equipped laboratory of established reputation, whose work and testing facilities shall be approved by the Owner. Approval of materials based on acceptable tests will apply only while such materials as furnished equal or exceed the tested samples or test specimens in quality and minimum requirements. Any change in origin, method of preparation, or manufacture of such materials will require new tests and approval thereof. Reports of all tests shall be furnished to the Owner in as many certified counterparts as may be required by the said owner.

GC-51 TESTING OF COMPLETED WORK

Before final acceptance, all parts of the work shall be tested and each part shall be in good condition and working order and shall be placed in such condition and order, at the expense of the Contractor. All tests of completed work required under this Contract shall be made under the direction of the Engineer-Architect by and at the expense of the Contractor, whom shall repair at their own expense all damage resulting from the testing.



GC-52 REMOVAL OF CONDEMNED MATERIALS AND STRUCTURES

The Contractor shall remove from the site of the work, without delay, all rejected and condemned materials or structures of any kind brought to or incorporated in the work, and upon their failure to do so, or to make satisfactory progress in so doing, within forty-eight (48) hours after the serving of a written notice from the Engineer-Architect ordering such removal, the condemned material or structures may be removed by the owner and the cost of such removal be taken out of the money that may be due or may become due the Contractor on account of or by virtue of this Contract. No such rejected or condemned material shall again be offered for use by the Contractor under this or any other contract under this project.

GC-53 PLACING WORK IN SERVICE

If desired by the Owner, portions of the work may be placed in service when completed and the Contractor shall give proper access to the work for this purpose, but such use and operation shall not constitute an acceptance of the work, and the Contractor shall be liable for defects due to faulty construction until the entire work under this Contract is finally accepted and for a year thereafter as stipulated in paragraph GC-55.

GC-54 DISPOSAL OF TRASH AND DEBRIS

The Contractor shall not allow the site of the work to become littered with trash and waste materials but shall maintain the same in a neat and orderly condition throughout the construction period. The Engineer-Architect shall have the right to determine what is or is not waste material or rubbish and manner and place of disposal. On or before the completion of the work the Contractor shall (without charge) carefully clean out all pits, pipes, chambers, or conduits, and shall tear down and remove all temporary structures built by them and shall remove all rubbish of every kind from the tracts or grounds which they have occupied and shall leave them in a first class condition.

GC-55 DEFECTIVE WORKMANSHIP AND MATERIALS

During a period of one (1) year from and after the date the final acceptance by the Owner of the work embraced by this Contract, the Contractor shall make all needed repairs arising out of defective workmanship or materials, or both, which, in the judgment of the Owner, shall become necessary during such period. If within ten (10) days after the mailing of a notice in writing to the Contractor, or their agent, the said Contractor shall neglect to make, or undertake with due diligence to make, the aforesaid repairs, the Owner is hereby authorized to make such repairs at the Contractor's expense providing, however, that in case of an emergency where, in the judgment of the Owner, delay would cause serious loss or damage, repairs may be made without notice being sent to the Contractor, and the Contractor shall pay the cost thereof.

GC-56 EQUIPMENT GUARANTY

All mechanical and electrical equipment and devices, and every part thereof, which are furnished by the Contractor under the terms of this Contract shall be guaranteed by the Contractor and their surety against defective workmanship, faulty design, mechanical and physical defects, leakage, breakage, and other damage or failure, under normal operation of the equipment and devices under specified conditions, for a period of one (1) year, unless specified in the Technical Specifications for a longer period from and after the date of acceptance thereof by the Owner, and each item of equipment or part thereof thus proving to be defective within the specified period of the guaranty shall be replaced (without cost to the Owner) by the manufacturer of the defective item of equipment, by the Contractor, or by their surety under the terms of the performance, payment and maintenance bond. This equipment guaranty shall also apply to, and shall include, any and all replacements of defective



equipment or parts made thereunder, and the period of the guaranty of each such replacement shall be from and after the date of installation thereof.

GC-57 CLAIMS FOR LABOR AND MATERIALS

The Contractor shall indemnify and save harmless the Owner from all claims for labor and materials furnished under this Contract, or any alterations or modifications thereof, and shall furnish the owner with satisfactory evidence, when called for by it, and that all persons, firms, or corporations, who have done work or furnished materials under this Contract, for which the Owner may become liable under the laws of the State, have been fully paid or satisfactorily secured, and in case such evidence is not furnished, an amount necessary or sufficient, within the discretion of the Owner, to meet the claims of the persons, firms and corporations, aforesaid, in addition to any other moneys that are to be retained, as herein specified, from the money due the Contractor under this Contract, shall be retained until the liabilities aforesaid shall be fully discharged or satisfactorily secured.

GC-59 ESTIMATED QUANTITIES

The Contractor agrees that the quantities of work as stated in this Invitation to Bid, or indicated on the Plans, are accurate for the construction shown, and that during the progress of the work the Owner may find it advisable, and it shall have the right, to omit portions of the Work and to increase or decrease the quantities, and that the Owner reserves the right to add to or take from any items as may be deemed necessary or desirable. Under no circumstances or conditions will the Contractor be paid anything on account of anticipated profits upon the work or any portion thereof covered by this Contract, which has not actually entered into the construction of said improvements.

GC-60 MONTHLY ESTIMATES AND PAYMENTS

- a. Unit Price Contracts: On or about the first day of each month, the Engineer-Architect will make an approximate estimate of the value of the work done and unused materials delivered for, and stored on, the site of the work during the previous calendar month. The Contractor shall furnish to the Engineer-Architect such detailed information as requested to aid them as a guide in the preparation of monthly estimates.
- b. Lump Sum Contracts: On or about the first day of each month the Contractor shall submit to the Engineer - Architect an itemized application for payment, supported to the extent required by the Engineer-Architect by receipts or other vouchers, showing payments for materials and labor, payments to subcontractors and such other evidence of the Contractor's right to payment as the Engineer-Architect may direct. If payments are made on valuation of work done, the Contractor shall, before the first application, submit to the Engineer-Architect a schedule of values of the various parts of the work, including quantities, aggregating the total sum of the Contract, divided so as to facilitate payments to subcontractors in accordance with such forms as the Engineer-Architect and the Contractor may agree upon, and, if required, supported by such evidence as to its correctness as the Engineer-Architect may direct. This schedule, when approved by the Engineer-Architect shall be used as a basis for Certificates for Payment, unless it is found to be in error. In applying for payments, the Contractor shall submit a statement based upon this schedule. If payments are made on account of materials not incorporated in the work but delivered and suitably stored at the site, or at some other location agreed upon in writing, such payments shall be conditioned upon submission by the Contractor of bills of sale or such other procedure as will establish the Owner's title to such material or otherwise adequately protect the Owner's interest including applicable insurance.
- c. Certification for Payments: On or about the 10th day of the month the Engineer-Architect shall submit payment estimates or certificates of payment to the Owner. After the Owner shall have approved each such estimate, the Owner shall pay to the Contractor ninety-five percent (95%)

of the amount of such estimated sum within thirty (30) days after receipt of payment certificate. If the Owner shall at any time fail to make the Contractor a monthly estimate at the time herein specified, such failure shall not be held to vitiate or void this Contract.

GC-61 LIENS

Neither the final payment nor any part of the retained percentage shall become due until the Contractor shall deliver to the Owner a complete release of all liens arising out of the Contract, or receipts in full in lieu thereof and, if required in either case, an affidavit that so far as they have knowledge or information the releases and receipts include all the labor and material for which a lien could be filed, but the Contractor may, if any subcontractor refuses to furnish a release or receipt in full, furnish a bond satisfactory to the Owner, to indemnify themselves against any lien. If any lien remains unsatisfied after all payments are made, the Contractor shall refund to the Owner all moneys that the latter may be compelled to pay in discharging such a lien, including all costs and a reasonable attorney's fee.

GC-62 COMPLETION AND ACCEPTANCE OF WORK

The Contractor shall make final corrections promptly as instructed and/or listed in writing by the Engineer-Architect. Upon completion of the work the Engineer-Architect shall satisfy themselves, by examination and test, that the work has been finally and fully completed in accordance with the Plans, Technical Specifications, and Contract and report such completion to the Owner.

GC-63 FINAL ESTIMATE AND PAYMENT

After official approval and acceptance of the work by the Owner, the Engineer-Architect shall be authorized to prepare a final estimate of the work done under this Contract and the value thereof. Such final estimate shall be submitted to the Owner within ten (10) days after its preparation has been authorized as aforesaid, and the Owner shall within thirty (30) days after said final estimate is made and certified, pay the entire sum found to be due hereunder, after deducting all amounts to be kept and retained under any provision of this Contract. All prior estimates and payments shall be subject to correction in the final estimate and payment, but in the absence of error or manifest mistake, it is agreed that all estimates, when approved by the Owner, shall be conclusive evidence of the work done and materials furnished.

GC-64 RELEASE OF LIABILITY

The acceptance by the Contractor of the last payment shall operate as, and shall be, a release to the Owner and every officer and agent thereof, from all claims and liability to the Contractor for anything done or furnished for, or relating to the work, or for any act or neglect of the Owner or any person relating to or affecting the work, and following such acceptance, no persons, firm, or corporation, other than the signer of this Contract as Contractor, will have any interest hereunder, and no claim shall be made or be valid, and neither the Owner nor any employee or agent thereof shall be liable or be held to pay any money, except as herein provided.

GC-65 CLAIMS FOR ADJUSTMENT AND DISPUTES

If for any reason the Contractor deems that additional compensation is due to them for work or materials not clearly provided for in the Contract, Plans, or Technical Specifications, or previously authorized as extra work, they shall notify the Engineer in writing of their intention to claim such additional compensation before they begin the work on which they base the claim. If such notification is not given or the Engineer is not afforded proper opportunity by the Contractor for keeping strict account of actual cost as required, then the Contractor hereby agrees to waive any claim for such additional compensation.



Such notice by the Contractor and the fact that the Engineer has kept account of the cost of the work shall not in any way be construed as proving or substantiating the validity of the claim.

When the work, on which the claim for additional compensation is based, is work that has been completed, the Contractor shall, within fifteen (15) calendar days after completion of the work in question, submit their written claim to the Engineer who will present it to the Owner for consideration. Claims submitted at times other than those herein specified will not be considered. Each notice of claim shall contain an itemized statement showing completely and fully the items and amounts forming the basis of the claim.

Nothing in this subsection shall be construed as a waiver of the Contractor's right to dispute final payment based on differences in measurements or computations.

END OF SECTION



PUBLIC WORKS SPECIAL CONDITIONS

These Special Conditions constitute modifications, deletions and additions to the General Conditions (GC). Where any part of the General Conditions is so modified by these Special Conditions the unaltered provision shall remain in effect.

SC-1 SCOPE OF WORK (GC-1)

The work provided for in these specifications shall consist of furnishing all labor, materials, equipment, and other services necessary to complete the work as described herein.

SC-6 COPIES OF CONTRACT (GC-6)

Six (6) copies of the contract documents will be prepared by the County. All copies will be submitted to the Contractor and the Contractor shall execute the Contract Agreements, insert executed copies of the required Performance Bonds, Certificate of Liability Insurances, Power of Attorney, and submit all copies to the County. THE DATE OF THE CONTRACT AGREEMENT AND BOND FORMS SHALL BE LEFT BLANK FOR FILLING IN BY THE COUNTY.

The County will execute all copies, insert the date of contract on the Performance Bonds and Power of Attorney, retain four (4) copies, and forward two (2) copies to the Contractor, one of which should be forwarded to the surety company.

SC-7 SCOPE, NATURE AND INTENT OF SPECIFICATIONS AND PLANS (GC-7)

- (1) All work on this project shall conform to the project drawings Jackson County, Missouri Invitation to Bid No. 41-22 and to the Contract Documents.
- (2) The work shall also conform to referenced standard drawings and to other drawings or information thereto as may be furnished by the Owner prior to the opening of the bids or during construction.
- (3) The following specifications are hereby incorporated into the Contract Documents:
 - a. The "Missouri Standard Specifications for Highway Construction", 2022 edition plus quarterly supplements as published by the Missouri Department of Transportation (MoDOT) are hereby incorporated into the Contract Documents
 - b. "Standard Specifications and Design Criteria", Current Edition as published by the Kansas City Metropolitan Chapter of the American Public Works Association (APWA)
 - c. 2009 International Building Code published by the International Code Council
 - d. 2009 Uniform Plumbing Code
 - e. 2009 International Mechanical Code
 - f. 2008 National Electrical Code published by the International Code Council
 - g. 2009 International Uniform Fire Code published by the International Code Council

h. 2009 International Existing Building Code

- (4) All work shall be in accordance with the Technical Specifications incorporated into this Project Manual except where a conflict occurs. Should any conflict arise in the Contract Documents, Standard Specifications or Plans the following order of precedence shall be used:
 - a. Plans – or Appendix sheets
 - b. Technical Specifications
 - c. Special Conditions
 - d. General Conditions
- (5) The Contractor, Subcontractors, and fabricators shall be in compliance with all Local, State and Federal Regulations:
 - a. Occupational Safety and Health Act of 1970, (29CFR1910) Public Law #91-956, current provisions and regulations as pertains to Work being performed on this project. (OSHA)
 - b. Occupational Safety and Health Standards, Part 1910, Chapter 17 of Title 29, Code of Federal Regulations, current provisions and regulations as pertains to Work being performed on this project.
 - c. The Consumer Product Safety Act as it relates to building materials and construction.
 - d. Safety and Health Regulations for Construction, Part 1518, Chapter 13 of Title 29, Code of Federal Regulations, current provisions and regulations as pertains to Work being performed on this project.

SC-9 CONTRACTOR TO CHECK PLANS AND SCHEDULE (GC-9)

Modify GC-9 as follows:

- (1) The Contractor shall submit a proposed progress schedule for all work in the Contract. Scheduling shall provide for the least practical inconvenience to the traveling public and to the residents along the project.
- (2) The construction schedule shall be in a form approved by the Owner and shall include at least the following information for each significant work item:
 - a. Beginning date.
 - b. Scheduled percentage of completion at the end of each calendar month.
 - c. Ending date.

The schedule shall also show the scheduled percentage complete for the entire contract at monthly intervals.

- (1) The Owner will review the proposed progress schedule and may require the Contractor to revise it if, in the Owner's judgment, changes are required to accurately reflect the scheduled progress of the work or provide for completion of the project within the contract time. The revised schedule shall be submitted to the Owner for their approval within fourteen (14) days of notification to the Contractor that a revised schedule is required.
- (2) The Contractor will be required to revise their original approved progress schedules any time actual progress of the Work on the Contract lags the schedule progress by fifteen percent or more. A revised schedule shall be submitted to the Owner for their approval within fourteen (14) days of written notification to the Contractor that a revised schedule is required. Prior to the beginning or during the progress of the work, if subsurface or latent physical conditions are encountered at the site differing materially from those indicated in the contract or if unknown physical conditions of an unusual nature, differing materially from those ordinarily encountered and generally recognized as inherent in the work provided for in the Contract, are encountered at the site, the party discovering such conditions shall promptly notify the other party in writing of the specific differing conditions before they are disturbed and the affected work is performed.
- (3) Upon written notification the County will investigate the conditions and if they determine that the conditions materially differ and cause an increase or decrease in the cost or time required for the performance of any work under the contract, an adjustment will be made and the contract modified in writing accordingly. The County will notify the Contractor of their determination whether or not an adjustment of the Contract is warranted.
- (4) No contract adjustment, which results in a benefit to the Contractor, will be allowed unless the Contractor has provided the required written notice.
- (5) The County may withhold monthly Progress Payments otherwise due to the Contractor in the event that progress falls fifteen (15) percent behind the approved progress schedule for two consecutive months, and may continue to withhold payments until the Contractor has submitted an acceptable revised schedule and shown a good faith effort to implement same. The County's decision either to withhold or not withhold progress payment shall not waive or release any right the County has to withhold any subsequent progress payments, nor does it relieve the Contractor of their responsibility to complete the project within the contract time.
- (6) No alteration to project schedule will be allowed for this contract by the contractor unless approved by the County.**

SC-12 OWNERSHIP OF DRAWINGS (GC-12)

General Conditions GC-12 is modified as follows:

All drawings, specifications, calculations, electronic files and copies developed by the Contractor and/or their subcontractors for components of the project are the property of the County. They are not to be used on work unrelated to this project, and, with exception of the Contractor's signed contract sets, are to be returned to the County on request, upon completion of the work.

SC-19 CONTRACTOR'S OFFICE AT SITE OF WORK (GC-19)

General Conditions GC-19 is modified by adding the following:

- (1) **The Contractor is not required to have a field office at the project site** and no conditions have been made by the County for the field office, shops, or storage areas to be used by the Contractor. However, if desired, the Contractor may, on their own initiative, provide for any or all of the above items. The Contractor may store a limited amount of material and equipment inside of the building in a specified location with the permission of the County, if applicable.
- (2) **No direct payment will be made for the Contractor's office, shops or storage areas.**
- (3) Common-Use Field Office: Of sufficient size to accommodate needs of County, Engineer and construction personnel office activities and to accommodate Project meetings. Keep office clean and orderly.
- (4) Storage and Fabrication Sheds: None allowed on site. Use interior space as approved by the County only as necessary. Prior to start of construction, the County will coordinate with the Contractor an inside and outside area location of the Jackson County Health Department such as 1st Floor designated area or portions of the Parking Lot based on availability with County personnel for staging and storage area.

SC-20 RESPONSIBILITY OF CONTRACTOR (GC-20)

General Conditions GC-20 is modified by adding the following:

Modify GC-20, Responsibility of Contractor, by adding the following:

- (1) Site Plan: Show temporary facilities, utility hookups, staging areas, and parking areas for construction personnel.
- (2) Fire-Safety Program: Show compliance with requirements of NFPA 241 and authorities having jurisdiction. Indicate Contractor personnel responsible for management of fire prevention program.
- (3) The Contractor shall take the necessary precautions to keep loose aggregate, mud and debris from being deposited onto open lanes of the existing, or offsite, paving during construction operations. Should aggregate mud and debris become deposited upon such open lanes of existing paving, the Contractor shall promptly remove it at no additional cost to the County.

- (4) Before the work will be accepted by the County, the Contractor shall be required to remove all aggregate and debris resulting from their operation, which also includes cleaning of streets, ditches, creeks, and driveways of earth, sod or other objectionable material and shall dispose of such debris off the project. This cleanup shall be limited to the project limits.
- (5) It is the responsibility of the Contractor to coordinate all removal and construction activities with Utility Owners.
- (6) Electric Service: Comply with NECA, NEMA, and UL standards and regulations for temporary electric service. Install service to comply with NFPA 70.
- (7) The Contractor at their sole cost and expense will provide all potable and non-potable water, power, and telephone service required along the project route in connection with the work to be performed.
- (8) All power for lighting, operation of the Contractor's equipment, or for any other use by the Contractor, shall be provided by the Contractor at his sole cost and expenses.
- (9) Tests and Inspections: Arrange for authorities having jurisdiction to test and inspect each temporary and permanent utility before use. Obtain required certifications and permits.
- (10) Temporary Use of Permanent Facilities: Engage Installer of each permanent service to assume responsibility for operation, maintenance, and protection of each permanent service during its use as a construction facility before Owner's acceptance, regardless of previously assigned responsibilities.
- (11) Locate facilities within the building where they will serve Project adequately and result in minimum interference with performance of the Work. Relocate and modify facilities as required by progress of the Work.
- (12) Telephone Service: Provide temporary telephone service in common-use facilities for use by all construction personnel. Install one telephone line(s) for each field office.
 - a. Provide additional telephone lines for the following:
 - i. Provide a dedicated telephone line for each facsimile machine in each field office.
 - b. At each telephone, post a list of important telephone numbers.
 - i. Police and fire departments.
 - ii. Ambulance service.
 - iii. Contractor's home office.

- iv. Contractor's emergency after-hours telephone number.
 - v. Engineers' offices.
 - vi. Owner's office.
 - vii. Principal subcontractors' field and home offices.
 - c. Provide superintendent with cellular telephone or portable two-way radio for use when away from field office.

- (13) Dewatering Facilities and Drains: Comply with requirements of authorities having jurisdiction. Maintain Project site, excavations, and construction free of water.
 - a. Dispose of rainwater in a lawful manner that will not result in flooding Project or adjoining properties or endanger permanent Work or temporary facilities.
 - b. Remove snow and ice as required to minimize accumulations.

- (14) Waste Disposal Facilities: Provide waste-collection containers in sizes adequate to handle waste from construction operations. Comply with requirements of authorities having jurisdiction.

- (15) Existing Stair Usage: Use of Owner's existing stairs will be permitted, provided stairs are protected, cleaned and maintained in a condition acceptable to Owner. At Substantial Completion, restore stairs to condition existing before initial use.

- (16) Provide protective coverings, barriers, devices, signs, or other procedures to protect stairs and to maintain means of egress. If stairs become damaged, restore damaged areas so no evidence remains of correction work.

- (17) Temporary Use of Permanent and/or Restored Stairs: Use of permanent and/or restored stairs for construction traffic will be permitted, provided stairs are protected and finishes restored to new condition at time of Substantial Completion.

- (18) SECURITY AND PROTECTION FACILITIES INSTALLATION
 - a. Protection of Existing Facilities: Protect existing vegetation, equipment, structures, utilities, and other improvements at Project site and on adjacent properties, except those indicated to be removed or altered. Repair damage to existing facilities.
 - b. Environmental Protection: Provide protection, operate temporary facilities, and conduct construction as required to comply with environmental regulations and that minimize possible air, waterway, and subsoil contamination or pollution or other undesirable effects.
 - c. Pest Control: Engage pest-control service to recommend practices to minimize attraction and harboring of rodents, roaches, and other pests and to perform extermination and control procedures at regular intervals so Project will be free of

- pests and their residues at Substantial Completion. Perform control operations lawfully, using environmentally safe materials.
- d. Barricades, Warning Signs, and Lights: Comply with requirements of authorities having jurisdiction for erecting structurally adequate barricades, including warning signs and lighting.
 - e. Temporary Enclosures: Provide temporary enclosures for protection of construction, in progress and completed, from exposure, foul weather, other construction operations, and similar activities. Provide temporary weather-tight enclosure for building exterior.
 - i. Where heating or cooling is needed and permanent enclosure is not complete, insulate temporary enclosures.
 - f. Temporary Partitions: Provide floor-to-ceiling dustproof partitions, as necessary, to limit dust and dirt migration into preservation zones such as the stairwells.
 - i. Construct dustproof partitions with two layers of 6-mil (0.14-mm) polyethylene sheet on each side. Cover floor with two layers of 6-mil (0.14-mm) polyethylene sheet, extending sheets 18 inches (460 mm) up the sidewalls. Overlap and tape full length of joints. Cover floor with fire-retardant-treated plywood.
 - ii. Protect air-handling equipment.
 - iii. Provide walk-off mats at each entrance through temporary partition.
 - g. Temporary Fire Protection: Install and maintain temporary fire-protection facilities of types needed to protect against reasonably predictable and controllable fire losses. Comply with NFPA 241; manage fire prevention program.
 - i. Prohibit smoking at Project site.
 - ii. Supervise welding operations, combustion-type temporary heating units, and similar sources of fire ignition according to requirements of authorities having jurisdiction.
 - iii. **Contractor shall acquire a Hot Work Permit from JCPW prior to Welding Operations. The Contractor shall have a copy of the Hot Work Permit on site and give a copy to the Owner for their records.**
 - iv. Develop and supervise an overall fire-prevention and -protection program for personnel at Project site. Review needs with local fire department and establish procedures to be followed. Instruct personnel in methods and procedures. Post warnings and information. Provide temporary standpipes and hoses for fire protection. Hang hoses with a warning sign stating that hoses are for fire-protection purposes only and are not to be removed. Match hose size with outlet size and equip with suitable nozzles.

(19) MOISTURE AND MOLD CONTROL

- a. Contractor's Moisture Protection Plan: Avoid trapping water in finished work. Document visible signs of mold that may appear during construction.

- b. Controlled Construction Phase of Construction: After completing and sealing of the building enclosure but prior to the full operation of permanent HVAC systems, maintain as follows:
 - i. Control moisture and humidity inside building by maintaining effective dry-in conditions.
 - ii. Remove materials that cannot be completely restored to their manufactured moisture level within 48 hours.

(20) OPERATION, TERMINATION, AND REMOVAL

- a. Supervision: Enforce strict discipline in use of temporary facilities. To minimize waste and abuse, limit availability of temporary facilities to essential and intended uses.
- b. Maintenance: Maintain facilities in good operating condition until removal.
 - i. Maintain operation of temporary enclosures, heating, cooling, humidity control, ventilation, and similar facilities on a 24-hour basis where required to achieve indicated results and to avoid possibility of damage.
 - ii. Temporary Facility Changeover: Do not change over from using temporary security and protection facilities to permanent facilities until Substantial Completion.
 - iii. Termination and Removal: Remove each temporary facility when need for its service has ended, when it has been replaced by authorized use of a permanent facility, or no later than Substantial Completion. Complete or, if necessary, restore permanent construction that may have been delayed because of interference with temporary facility. Repair damaged Work, clean exposed surfaces, and replace construction that cannot be satisfactorily repaired.
 - 1. Materials and facilities that constitute temporary facilities are property of Contractor.
 - 2. At Substantial Completion, repair, renovate, and clean permanent facilities used during construction period.

(21) Temporary Traffic Control:

- (1) Flagging and traffic control signing shall be in accordance with the contract documents and the MUTCD. It shall be the contractor's responsibility to check the traffic control devices each evening to make sure they are in place before leaving the jobsite.
- (2) As an obligation of the contract, the Contractor shall sign all road closures and establish such detours as needed and as approved by the County.
- (3) **Direct payment will be made for Traffic Control. See Technical Specifications of this contract for "Traffic Control" as Lump Sum for ALL Unit Bids.**
- (4) Additionally the Contractor shall install proper signage to warn motorists of loose gravel and oil.

- (5) All personnel utilized in traffic control shall be fluent in English. Fluency shall be as determined by the Engineer in the Field Personnel not meeting this requirement shall not be utilized in the work.
- (6) Additionally drivers operating vehicles or equipment on public roads shall possess valid driver's licenses issued in the United States. The driver's license must be appropriate to the vehicle they are operating.

(22) WATER, POWER AND SANITATION:

- (1) Arrange with utility company and Owner for time when service can be interrupted, if necessary, to make connections for temporary services. Contractor must secure all necessary permits to cut and/or cap all utilities including water, gas, electricity, and sewer. Contact Missouri One Call System (1-800-344-7483 (DIG-RITE) and coordinate identification of ALL underground utilities. Consult with Evergy to coordinate the protection of power lines adjacent to the building.
- (2) Water: All water required along the project route in connection with the work to be performed by the Contractor will come from Owner's existing water system is available for use without metering and without payment of use charges. Provide connections, backflow protection and extensions of services as required for construction operations. Contractor shall coordinate with the **City of Lee's Summit Water Department** prior to start of construction and acquire permits as required by the City. Shutoff valves shall be placed by the contractor for each bathroom prior to any and all construction to the bathroom to not disrupt the daily operations of the **Health Department**. The locations of the shutoff valves shall be coordinated with the Owner. Contractor shall provided sketches, shop drawings, shutoff valve materials and specifications to the Owner. Clean and maintain water service facilities in a condition acceptable to Owner. At Substantial Completion, restore these facilities to condition existing before initial use.
- (3) Power: All power for lighting, operation of the Contractor's office or equipment, or for any other use by the Contractor, is available for use without metering and without payment of use charges. Contractor shall coordinate with the Evergy prior to start of construction. Provide connections and extensions of services as required for construction operations.
- (4) Sanitation: The Contractor and subcontractor are allowed to use the existing sanitary facilities at the **Health Department**. They are available for use without metering and without payment of use charges. Provide connections, backflow protection and extensions of services as required for construction operations.

Connect temporary sewers to municipal system as directed by authorities having jurisdiction.

- (5) The Contractor is to note that there are utilities on the project site, see Construction Plan sheets. The plans show the approximate horizontal and vertical locations of the known utilities by the designer and Owner. The contractor is responsible for ALL field verification of existing utilities prior to start of work. Any and ALL disruptions of utility service of the building operations during construction caused by the Contractor shall be coordinated, repaired, and fixed by the contractor, in accordance with the utility company standards and permits. The Owner shall not incur any additional costs of the utility work repairs or fixes by the contractor. All repairs and fixes of utility work shall be the sole expense of the contractor.

(23) SALVAGING DEMOLITION WASTE

(1) Salvaged Items for Reuse in the Work:

- i. Clean salvaged items.
- ii. Inventory, photograph, pack or crate items after cleaning. Identify contents of containers.
- iii. Store items in a secure area until installation.
- iv. Protect items from damage during transport and storage.
- v. Install salvaged items to comply with installation requirements for new materials and equipment. Provide connections, supports, and miscellaneous materials necessary to make items functional for use indicated.

(2) Salvaged Items for Sale and/or Donation: Not Permitted on Project site.

(3) Salvaged Items for Owner's Use:

- i. Clean salvaged items.
- ii. Inventory, photographs, pack or crate items after cleaning. Identify contents of containers.
- iii. Store items in a secure area until delivery to Owner.
- iv. Transport items to Owner's storage area designated by Owner.
- v. Protect items from damage during transport and storage.

(24) RECYCLING DEMOLITION AND CONSTRUCTION WASTE, GENERAL

(1) General: Recycle paper and beverage containers used by on-site personnel.

- (2) Recycling Incentives: Revenues, savings, rebates, tax credits, and other incentives received for recycling waste materials shall be shared equally by Owner and Contractor.

- (3) Procedures: Separate recyclable waste from other waste materials, trash, and debris. Separate recyclable waste by type at Project site to the maximum extent practical according to approved construction waste management plan.
 - i. Provide appropriately marked containers or bins for controlling recyclable waste until they are removed from Project site. Include list of acceptable and unacceptable materials at each container and bin.
 - ii. Inspect containers and bins for contamination and remove contaminated materials if found.
 - iii. Stockpile processed materials on-site without intermixing with other materials.
 - iv. Remove recyclable waste from Owner's property and transport to recycling receiver or processor.

(25) RECYCLING DEMOLITION WASTE

- (1) Wood Materials: Sort and stack members according to size, type, and length. Separate lumber, engineered wood products, panel products, and treated wood materials.
- (2) Metals: Separate metals by type.
 - i. Structural Steel: Stack members according to size, type of member, and length.
 - ii. Remove and dispose of bolts, nuts, washers, and other rough hardware.
 - iii. Gypsum Board: Stack large clean pieces on wood pallets or in container and store in a dry location. Remove edge trim and sort with other metals. Remove and dispose of fasteners.
 - iv. Piping: Reduce piping to straight lengths and store by type and size. Separate supports, hangers, valves, sprinklers, and other components by type and size.
 - v. Conduit: Reduce conduit to straight lengths and store by type and size.

(26) DISPOSAL OF WASTE

- (1) General: Except for items or materials to be salvaged, recycled, or otherwise reused, remove waste materials from Project site and legally dispose of them in a landfill or incinerator acceptable to authorities having jurisdiction.
 - i. Except as otherwise specified, do not allow waste materials that are to be disposed of accumulate on-site.
 - ii. Remove and transport debris in a manner that will prevent spillage on adjacent surfaces and areas.
- (2) Burning: Do not burn waste materials.
- (3) Disposal: Remove waste materials from Owner's property and legally dispose of them.
- (4) Storage: Offsite Storage of materials and equipment shall conform to manufacturer's recommendations. Offsite storage arrangements shall be approved by the County. Such offsite storage arrangements shall be presented in writing and shall afford

adequate and satisfactory security and protection by the contractor. Offsite storage facilities shall be bonded and accessible to the County. Onsite storage of materials and equipment shall conform to manufacturer's recommendations. Onsite Storage shall not interfere with public access and/or safety.

- (27) **Smoking is NOT permitted any time by the General Contractor and their Sub-contractor(s) at the construction site on Jackson County, MO. property before or during the duration of the construction.**

SC-25 METHODS OF OPERATION (GC-25)

- (01) General Conditions GC-25 is modified by adding the following In accordance with generally accepted construction practices, the Contractor shall assume sole and complete responsibility for job site conditions during the course of construction of the project, including safety of all persons and property.
- (02) Provide temporary barricades, as required to protect the public from harm due to construction activities.
- (03) Contractor shall coordinate with Jackson County Sheriff's Offices prior to start of construction to determine access and security measures inside and outside the Jackson County Health Department. See Appendix for Contract Staff Access Rules & Regulations Orientation form, Contract Staff Rules & Regulations Agreement form, and Access Application form. Both the General Contractor's and Sub-contractor's personnel shall fill out the forms prior to any and all construction.
- (04) If the Contractor plans to utilize NE Ralph Powell Road existing R/W next to Jackson County Health Department for temporary storage or staging area, then they will need to acquire R/W permits with a Traffic Control Plan from the City of Lee's Summit prior to start of construction. A copy of the Traffic Control Plan approved by the City shall be submitted to the County. The Traffic Control Plan will need to show Temporary Type 3 Barricades with Flashers and other traffic control devices as required to protect the public from harm due to construction activities. The Traffic Control Plan shall be in accordance with the current version of the Manual on Uniform Traffic Control Devices (MUTCD) by the Federal Highway Administration. The Traffic Control Plan, City permits and installation shall be subsidiary to all the Unit Prices of this contract.

SC-27 AUTHORITY AND DUTY OF THE ENGINEER-ARCHITECT (GC-27)

The progression of the project will be observed by the County personnel and will provide the inspection.

SC-28 INSPECTION (GC-28)

- A. This project will be observed by the County personnel and will provide the inspection.
- B. This project will use MODOT standard inspections protocol. Also, the contractor shall follow the MODOT Standards for Traffic Safety.
- C. All personnel within Jackson County Buildings (inside or outside existing or new buildings having new construction work), Jackson County, MO. Right-of-Way, Jackson County Parking Lots, Jackson County Sites (Demolition areas or new work) who are exposed to traffic or construction activities or construction equipment shall wear at ALL times High-Visibility Safety Apparel meeting Class 2 or Class 3 requirements of ANSI/ISEA 107-2004 Publication Entitled, "American National Standard for High-Visibility Safety Apparel and Headwear".
- D. Contractor shall follow all Occupational Safety and Health Administration (OSHA) construction safety standards and requirements.
- E. Contractor shall notify his subcontractors, Owner and all Contractors and subcontractors under the Owner, when they are ready for them to install their portions of their work and see that they comply within a reasonable amount of time. Neither enclose nor cover any piping, wiring, ducts, equipment or other items until proper tests, observations and/or inspections have been made by the Owner, Jackson County Building Inspector, and/or proper authorities.
- F. Contractor or subcontractor may not put in place any work which will prevent observation and approval of previous work without first notifying the Owner, Jackson County Building Inspector, and/or proper authorities.

SC-29 NO WAIVER OF RIGHT (GC-29)

Neither the inspection or evaluations by the County or any of the County's officials, employees, or agents, nor any order by the County for payment of money, nor any payment for, or acceptance of, the whole or any part of the work by the County or Engineer-Architect, nor any extension of time, nor any possession taken by the County or its personnel, shall operate as a waiver of any provision of this contract, or of any power herein reserved to the County, or any right to damages herein provided, or shall any waiver of any breach in this contract be held to be a waiver of any other or subsequent breach.

SC-32 PROTECTION OF PROPERTY AND PUBLIC LIABILITY (GC-32)

General Condition GC-32 is modified by adding the following:

- A. The Contractor shall exercise caution in performing tasks around the existing Bathrooms, offices, Conference rooms, lab rooms, hallways, and stairs at the Health Department building during all hours of operations and equipment. Any damage to the Jackson County structures or equipment through negligence on the part of the Contractor or their agents shall be repaired and paid for at the expense of the Contractor. Repairs shall not be considered complete until approved by the Owner.

- B. The Contractor shall be liable for any and all damage caused by Contractor to County's premises. The Contractor shall hold and save the County, agents and representatives, free and harmless from liability of any nature or any kind arising from any use, trespass or damage occasioned by Contractor's operations on premises or third persons.
- C. The Contractor shall confine all work, equipment and personnel within the limits of the existing project Right-of-Ways, Easements, and Construction Limits noted on the Construction Plans. The Contractor shall make no claim for additional payment for confining their operations within these areas.
- D. The Contractor shall take all precautions required to preserve and protect all existing trees, shrubs, and other improvements located within the project right-of-way and easements designated to be saved by this contract.
- E. The Contractor shall protect and preserve the Control Point survey pins as shown on the Construction Plans. If disturbed it is the contractor's responsibility to reset the pin by a licensed surveyor at the Contractor's expense.
- F. The Contractor is responsible for contacting the local property owners for any additional access areas they feel are necessary to complete the listed work. No direct payment will be made for the Contractor's securing additional access areas.
- G. The Contractor shall not interfere with the daily operations of the Jackson County Health Department building before, during, or after the construction of the specified items in these specifications
- H. The Contractor shall be responsible for the restoration of interior and exterior portions of the building, any paved, graveled, or grassed areas disturbed by construction. Any areas so affected shall be restored to a condition as nearly as possible to that existing prior to construction. Paved and graveled areas shall be resurfaced with materials meeting the requirements of the technical specifications, and grassed areas shall be seeded and mulched. No direct measurement or payment will be made for restoration of areas disturbed by activities outside of the limits designated on the Drawings.

SC-34 MODIFICATIONS AND ALTERATIONS (GC-34)

General Conditions GC-34 is modified by adding the following:

The Contractor may submit to the County, in writing, bids for modifying the plans, specifications or other requirements of this contract for the sole purpose of reducing the total cost of construction. The cost reduction bid shall not impair, in any manner, the essential functions or characteristics of the project, including but not limited to service life, economy of operation, and ease of maintenance, desired appearance, or design and safety standards.

Cost reduction bids shall contain the following information:

- A. A description of both the existing contract requirements for performing the work and the

proposed changes.

- B. An itemization of the contract requirements that must be changed if the bid is adopted.
- C. A detailed estimate of the cost of performing the work under the existing contract and under the proposed change.
- D. A statement of the time within which the County must make a decision thereon.
- E. The contract items of work affected by the proposed changes, including any quantity variation attributable thereto.
- F. This Special Condition shall not be construed to require the County to consider any cost reduction bid which may be submitted hereunder; proposed change in basic design of a bridge or of a pavement type will not be considered as an acceptable cost reduction bid; the Owner will not be liable to the Contractor for failure to accept or act upon any cost reduction bid submitted pursuant to this section nor for any delays to the work attributable to any such bid. If a cost reduction bid is similar to a change in the plans or specifications for the project under consideration by the Owner at the time said bid is submitted, the County will not accept such bid and the Owner reserves the right to make such changes without compensation to the Contractor under the provisions of this article.
- G. The Contractor shall continue to perform the work in accordance with the requirements of the contract until an executed change order incorporating the cost reduction bid has been issued. If an executed change order has not been issued by the date upon which the Contractor's cost reduction bid specified that a decision thereon should be made, or such other date as the Contractor may subsequently have specified in writing, such cost reduction bid shall be deemed rejected.
- H. The County shall be the sole judge of the acceptability of a cost reduction bid and of the estimated net savings in construction costs from the adoption of all or any part of such bid. In determining the estimated net savings, the right is reserved to disregard the contract bid prices if, in the judgment of the County, such prices do not represent a fair measure of the value of work to be performed or to be deleted.
- I. The Owner reserves the right where they deem such action appropriate to require the Contractor to share in the Owner's cost of investigating a cost reduction bid submitted by the Contractor as a condition of considering such bid. Where such a condition is imposed, the Contractor shall indicate acceptance thereof in writing, and such acceptance shall constitute full authority for the Owner to deduct amounts payable to the Owner from any moneys due or that may become due to the Contractor under the contract.
- J. If the Contractor's cost reduction bid is accepted in whole or in part, such acceptance will be by a contract change order, which shall specifically state that it is executed pursuant to this Article. Such change order shall incorporate the changes in the plans and specifications which are necessary to permit the cost reduction bid or such part of it as has been accepted to be put into effect, and shall include any conditions upon which the Owner's approval thereof is based if the

approval of the Owner is conditional. The change order shall also set forth the estimated net savings in the cost of performing the work attributable to the cost reduction bid effectuated by the change order and shall further provide the Contractor be paid fifty (50) percent of said estimated net savings amount.

- K. Acceptance of the cost reduction bid and performance of the work there under shall not extend the time of completion of the contract unless specifically provided for in the contract change order authorizing the use of the cost reduction bid.
- L. The amount specified to be paid to the Contractor in the change order which effectuates a cost reduction bid shall constitute full compensation to the Contractor for the cost reduction bid and the performance of the work thereof pursuant to the said change orders.
- M. The Owner expressly reserves the right to adopt a cost reduction bid for general use on contracts administered by the Owner when it determines that said bid is suitable for application to other contracts. When an accepted cost reduction bid is adopted for general use, only the Contractor who first submitted such bid will be eligible for compensation pursuant to this section, and, in that case, only as to those contracts awarded to them prior to submission of the accepted cost reduction bid. Cost reduction bids identical or similar to previously submitted bids will be eligible for consideration and compensation under the provisions of this article if the identical or similar previously submitted bids were not adopted for general application to other contracts administered by the Owner. Subject to the provisions contained herein, the Owner shall have the right to use all or any part of any submitted cost reduction bid without obligation or compensation of any kind to the Contractor.
- N. This article of the specifications shall apply only to contracts awarded to the lowest bidder pursuant to competitive bidding.
 - (1) The County reserves the right to make, in writing, at any time during the work, such changes in quantities and such alterations in the work as are necessary to satisfactorily complete the project. Such changes in quantities and alterations shall not invalidate the Contract nor release the surety, and the Contractor agrees to perform the work as altered.
 - (2) If the alterations or changes in quantities significantly change the character of the work under the Contract, whether or not changed by any such different quantities or alterations, an adjustment, excluding loss of anticipated profits, will be made to the Contract. The basis for the adjustment shall be agreed upon prior to the performance of the work. If a basis cannot be agreed upon, then an adjustment will be made either for or against the Contract in such an amount as the County may determine to be fair and equitable.
 - (3) If the alterations or changes in quantities do not significantly change the character of the work to be performed under the Contract, the altered work will be paid for as provided elsewhere in the Contract.
- O. The term "significant change" shall be construed to apply only to the following

circumstances:

- a. When the character of the work as altered differs materially in kind or nature from that involved or included in the original proposed construction or;
 - b. When a major item of work, as defined elsewhere in the Contract is increased in excess of 125 percent or decreased below 75 percent of the original Contract quantity. Any allowance for an increase in quantity shall apply only to the portion of the work in excess of 125 percent of original Contract item quantity, or in the case of decrease below 75 percent, to the actual amount of work performed.
 - c. The Contractor's attention is called to the **Pricing Sheet** and/or bid which allows the County to adjust the quantities upward or downward to be based upon the available funding. This may be in excess of the percentages noted above.
- P. COST REDUCTION INCENTIVE: The Contractor may submit to the Engineer, in writing, bids for modifying the plans, specifications or other requirements of this contract for the sole purpose of reducing the total cost of construction. The cost reduction bid shall not impair, in any manner, the essential functions or characteristics of the project, including but not limited to service life, economy of operation, and ease of maintenance, desired appearance, or design and safety standards.
- a. Cost reduction bids shall contain the following information:
 - i. A description of both the existing contract requirements for performing the work and the proposed changes.
 - ii. An itemization of the contract requirements that must be changed if the bid is adopted.
 - iii. A detailed estimate of the cost of performing the work under the existing contract and under the proposed change.
 - iv. A statement of the time within which the Engineer must make a decision thereon.
 - v. The contract items of work affected by the proposed changes, including any quantity variation attributable thereto.
 - b. The provisions of this Article shall not be construed to require the Engineer to consider any cost reduction bid which may be submitted hereunder; proposed change in basic design of a bridge or of a pavement type will not be considered as an acceptable cost reduction bid; the Owner will not be liable to the Contractor for failure to accept or act upon any cost reduction bid submitted pursuant to this section nor for any delays to the work attributable to any such bid. If a cost reduction bid is similar to a change in the plans or specifications for the project under consideration by the Owner at the time said bid is submitted, the Engineer will not accept such bid and the Owner reserves the right to make such changes without compensation to the Contractor under the provisions of this article.
 - c. The Contractor shall continue to perform the work in accordance with the requirements of the contract until an executed change order incorporating the cost reduction bid has been issued. If an executed change order has not been issued by the date upon which the

Contractor's cost reduction bid specified that a decision thereon should be made, or such other date as the Contractor may subsequently have specified in writing, such cost reduction bid shall be deemed rejected.

- d. The Engineer shall be the sole judge of the acceptability of a cost reduction bid and of the estimated net savings in construction costs from the adoption of all or any part of such bid. In determining the estimated net savings, the right is reserved to disregard the contract bid prices if, in the judgment of the Engineer, such prices do not represent a fair measure of the value of work to be performed or to be deleted.
- e. The Owner reserves the right where deemed such action appropriate to require the Contractor to share in the Owner's cost of investigating a cost reduction bid submitted by the Contractor as a condition of considering such bid. Where such a condition is imposed, the Contractor shall indicate their acceptance thereof in writing, and such acceptance shall constitute full authority for the Owner to deduct amounts payable to the Owner from any moneys due or that may become due to the Contractor under the contract.
- f. If the Contractor's cost reduction bid is accepted in whole or in part, such acceptance will be by a contract change order, which shall specifically state that it is executed pursuant to this Article. Such change order shall incorporate the changes in the plans and specifications which are necessary to permit the cost reduction bid or such part of it as has been accepted to be put into effect, and shall include any conditions upon which the Owner's approval thereof is based if the approval of the Owner is conditional. The change order shall also set forth the estimated net savings in the cost of performing the work attributable to the cost reduction bid effectuated by the change order and shall further provide the Contractor be paid fifty (50) percent of said estimated net savings amount.
- g. Acceptance of the cost reduction bid and performance of the work there under shall not extend the time of completion of the contract unless specifically provided for in the contract change order authorizing the use of the cost reduction bid.
- h. The amount specified to be paid to the Contractor in the change order which effectuates a cost reduction bid shall constitute full compensation to the Contractor for the cost reduction bid and the performance of the work thereof pursuant to the said change orders.
- i. The Owner expressly reserves the right to adopt a cost reduction bid for general use on contracts administered by the Owner when it determines that said bid is suitable for application to other contracts. When an accepted cost reduction bid is adopted for general use, only the Contractor who first submitted such bid will be eligible for compensation pursuant to this section, and, in that case, only as to those contracts awarded to them prior to submission of the accepted cost reduction bid. Cost reduction bids identical or similar to previously submitted bids will be eligible for consideration and compensation under the provisions of this article if the identical or similar previously submitted bids were not adopted for general application to other contracts administered by the Owner. Subject to the provisions contained herein, the Owner shall have the right to use all or any part of any submitted cost reduction bid without obligation or compensation of any kind to the Contractor.
- j. This article of the specifications shall apply only to contracts awarded to the lowest bidder pursuant to competitive bidding

SC-35 EXTRA WORK (GC-35)

General Conditions GC-35 is modified as follows for numbers 2, 3 and 4 of GC-35 as follows:

- A. An amount equal to 20% percent will be added to the bond, insurance and taxes and not the 6% noted in the General Condition.
- B. An amount equal to 20% percent will be added to the materials and not the 15% noted in the General Condition.
- C. An amount equal to 20% percent will be added to all rental costs and not the 15% noted in the General Condition.

SC-37 ASSIGNMENT AND SUBLETTING OF CONTRACT (GC-37)

Add to GC-37 the following requirement.

- A. "No Second-Tier subcontracting will be permitted. It shall be the responsibility of the Contractor to ensure that his/her subcontractors do not in turn subcontract any portion of the work."
- B. **The 50% of the contract work, noted in the General Conditions, shall be reduced to 35% for this project.**
- C. Assigning, transferring or subletting, even though consented to, shall not relieve the Contractor of their liabilities under his contract. The Contractor shall give it's personal attention to any and all portions of the contract which has been sublet and they shall be responsible for its proper construction.
- D. The prime Contractor, as a condition of this contract, is responsible for assuring submission of proof or documentation regarding Affirmative Action compliance by his subcontractors and for the subsequent Affirmative Action performance by such subcontractors.

SC-39 SUSPENSION OF WORK ON NOTICE (GC-39)

General Conditions GC-39 is modified by adding the following:

- A. If the performance of all or any portion of the work is suspended or delayed by the Engineer in writing for an unreasonable length of time (not originally anticipated, customary, or inherent to the construction industry) and the contractor believes that additional compensation and/or contract time is due as a result of such suspension or delay, the contractor shall submit to Engineer, in writing, a request for adjustment within seven (7) calendar days of receipt of the notice to resume work. The request shall set forth the reasons and support for such adjustment.
- B. Upon receipt, the engineer will evaluate the contractor's request. If the engineer agrees that the cost and/or time required for the performance of the contract has increased as a result of such

suspension and the suspension was caused by conditions beyond the control of and not the fault of the contractor, its suppliers, or subcontractors at any approved tier, and not caused by weather, the engineer will make an adjustment (excluding profit) and notify the contractor of his/her determination whether or not an adjustment of the contract is warranted.

- C. No contract adjustment will be allowed unless the contractor has submitted the request for adjustment within the time prescribed.
- D. No contract adjustment will be allowed under this clause to the extent that performance would have been suspended or delayed by any other cause, or for which an adjustment is provided for or excluded under any other term or condition of this contract. No contract adjustment will be made for utility delays.

SC-41 LAWS AND ORDINANCES (GC-41)

The following is added to GC-41:

No burning will be allowed.

SC-43 CHARACTER OF PERSONNEL (GC-43)

Add the following to GC-43:

Personnel who may have occasion to speak with the general public (i.e. flaggers, plumber, electrician) must be able to communicate in clear English.

SC-45 UNFAVORABLE CONSTRUCTION CONDITIONS (GC-45)

Modify GC-45, Unfavorable construction conditions, by adding the following:

Contractor shall take precautions by watering or other means to ensure that excessive dust or lime does not become airborne during construction.

SC-46 BEGINNING, PROGRESS, AND TIME OF COMPLETION OF WORK (GC-46)

Modify GC-46 by adding the following:

- A. The time for completion of the work is an essential part of the Contract. It shall begin on the date stated in the Notice to Proceed, and shall be the number of working days as stated in the Bid and in accordance with MoDOT Standard Specification Section 108, except as follows: "No working days will be counted from December 15 to March 15, both days inclusive unless work may proceed on a continuous basis beyond December 15 or may start or restart on a continuous basis before March 15. Working days will not be counted within this time frame after continuous work stops or before continuous work begins. Saturdays, Sundays, national holidays and holidays established by the laws of the state will not be counted as working days any time during the year."
- B. Contractor's attention is directed to conditions of GC-44 and GC-46. Holidays: Saturdays,

Sundays, and holidays established by the laws of the County will not be counted as working days.

2022 List of Jackson County, Missouri Holidays

New Year's Day	Saturday, January 1 st (Observed Friday, December 31 st)
Martin Luther King, Jr Day	Monday, January 17 th
Presidents' Day	Monday, February 21 st
Truman's Birthday	Sunday, May 8 th (Observed Monday, May 9 th)
Memorial Day	Monday, May 30 th
Juneteenth	Sunday, June 19 th (Observed Friday, June 17 th)
Independence Day	Monday, July 4 th
Labor Day	Monday, September 5 th
Veterans' Day	Friday, November 11 th
Thanksgiving Day	Thursday, November 24 th
Thanksgiving Friday	Friday, November 25 th
Christmas Day	Sunday, December 25 th (Observed Monday, December 26 th)

- C. In the event that a holiday falls on a Saturday, the preceding Friday shall be observed as a holiday. If a holiday falls on a Sunday, the following Monday shall be observed as a holiday.
- D. The Contractor will need to coordinate with the County, the Sheriff's Office, and/or their designated representative on the after-work week hours and weekend schedules. The standard work week hours that the Contractor can work are from 7:30 A.M. to 6:00 P.M.
- E. Weekend work schedule(s) shall be coordinated and approved with the County prior to any construction. The Contractor shall take, at no additional cost to the Owner, whatever means are necessary including, but not necessarily limited to, working nights and weekends and double shifts, and providing temporary weather enclosures and temporary heat/ventilation during inclement weather to assure substantial completion of all work during the Contract Time.
- F. The Contractor shall take, at no additional cost to the County, whatever means are necessary including, but not necessarily limited to, working nights and weekends and double shifts, and providing temporary weather enclosures and temporary heat/ventilation during inclement weather to assure substantial completion of all work during the Contract Time.
- G. Prior to starting work, a PRE-CONSTRUCTION CONFERENCE will be held to discuss the project, its scheduling, and its coordination with the work of others. It is expected that this conference will be attended by representatives of the County, the Engineer, the Contractor and their subcontractors, plumber, and the Utilities, as well as representatives of any other

affected agencies which the Owner may wish to invite.

- H. The demolition or construction of the bathrooms, offices, lab room or other project items that has extensive noise shall be performed from 5:00 p.m. to 10:00 p.m. during the weekdays. Removal of any hazardous materials encountered by the Contractor shall be after be formed from 6:00 p.m. to 10:00 p.m. during the week days or the weekend per approval of the Owner. This shall be coordinated with the Owner and the Sheriff's Offices.
- I. Substantial Completion shall be the stage in the progress of the Work where the Work is sufficiently complete in accordance with the Contract Documents so that the County can occupy or utilize the Work for its intended user.

SC-48 EXTENSION OF TIME (GC-48)

Add to GC-48 by adding the following:

- A. The County has shown on the Plans, from the information available, existing aboveground and underground installations and structures which may be affected by the work but there is no guarantee that all such facilities are shown. The location, depth and size of each facility shown on the Plans are approximate only and are not guaranteed correct. If utilities are damaged through carelessness or neglectful action by the Contractor, they will be repaired by the Contractor or authorities having control of the same, but the cost of such repairs shall be paid by the Contractor.
- B. Delays due to utility conflicts will not be cause for extension of time or adjustments in contract amount.
- C. The Contractor shall contact each utility agency or other owner of public or private property in advance of any operations which may affect any of the agencies' or property owners' facilities and shall enlist their assistance in the location of their existing or relocated utilities.
- D. The Contractor shall make every effort to locate all existing facilities, which may be affected by the work, including prospecting or excavating beneath the surface. No payment will be made to the Contractor in connection with location of existing facilities.
- E. All fire hydrants and water control valves shall be kept free from obstructions and available for use at all times, except as herein allowed.
- F. In the event of interruption to utility services as a result of accidental breakage or as a result of being exposed or unsupported, the Contractor shall promptly notify the proper authority and shall cooperate with the said authority in the restoration of service. If utility service is interrupted, continuous cooperation will be required until the service is restored.

SC-49 LIQUIDATED DAMAGES (GC-49)

In accordance with GC-49, Liquidated Damages (also referred to as "Schedule of Deductions"), the Contractor will be assessed liquidated damages for each calendar day of delay in completion of work.

See the following schedule:

	<u>Contract Amount</u>	<u>Calendar Day Assessment</u>	
	\$ 0	\$ 25,000	\$ 475
	\$ 25,001	\$ 50,000	\$ 475
	\$ 50,001	\$ 100,000	\$ 500
	\$ 100,001	\$ 500,000	\$ 700
	\$ 500,001	\$ 1,000,000	\$ 950
	\$ 1,000,001	\$ 2,000,000	\$ 1,100
	\$ 2,000,001	\$ 3,000,000	\$ 1,225
	\$ 3,000,001	\$ 4,000,000	\$ 1,625
	\$ 4,000,001	\$ 5,000,000	\$ 2,025
	\$ 5,000,001	\$ 6,000,000	\$ 2,425
	\$ 6,000,001	\$ 7,000,000	\$ 2,825
	\$ 7,000,001	\$ 8,000,000	\$ 3,225
	\$ 8,000,001	\$ 9,000,000	\$ 3,625
	\$ 9,000,001	\$ 10,000,000	\$ 4,025
	\$ 10,000,001	\$ 70,000,000	\$ 4,300

SC-50 TEST OF MATERIALS OFFERED BY CONTRACTOR (GC-50)

Modify GC-50, Tests of Materials offered by Contractor, by adding the following:

- A. Submission of all Compliance Submittals shall be scheduled to permit review, fabrication, and delivery in time to cause no delay in the Work of Contractor or their subcontractors or any other contractors as described herein. Contractor shall allow fifteen (15) days in County's office for reviewing original submittals and fifteen (15) days in County's office for reviewing re-submittals.

- B. Compliance submittals of materials furnished by subcontractors, manufacturers, and suppliers shall be submitted by the Prime Contractor.

- C. In general, the Specifications identify required materials and equipment by naming one or more manufacturer's brand, model, catalog number and/or other identification; first-named manufacturer's product used as the basis for design; other named brands considered equivalent. Equivalent brand manufacturers named must furnish products consistent with Specifications for first-named product, as determined by County. Base Bid shall include only those brands named, except as hereinafter provided.

D. Where materials or equipment are described but not named, Contractor shall provide required first quality items, adequate in every respect for intended use, such items subject to County's approval prior to procurement.

A. Submit certificates for the following materials:

- 1) Patch SOG
- 2) 42" High Painted Metal Guard Panel
- 3) Modify Existing SS Handrail Extension
- 4) Modify Existing Painted Handrail Extension
- 5) Interior Blockings
- 6) Reception Desk
- 7) Base Cabinet
- 8) Island Cabinet
- 9) Wall Cabinet
- 10) Counter
- 11) Registration Counter
- 12) Millwork
- 13) Joint Sealants
- 14) Hollow Metal Doors and Frames
- 15) Wood Doors
- 16) Interior Storefront
- 17) Aluminum Sliding Door and Frame
- 18) Door Hardware
- 19) Gypsum System
- 20) Rubber Resilient Wall Base and Accessories
- 21) Linoleum Flooring
- 22) Carpet Tile
- 23) Vinyl Wall Covering
- 24) Paint
- 25) White Board Visual Display Units
- 26) Building Directory
- 27) Room identification panel signage
- 28) Parking signage
- 29) New hinges on existing partition
- 30) Pull Handles on existing partition
- 31) Operable Wall Partitions
- 32) Toilet paper dispenser
- 33) Grab bars
- 34) Specimen Pass-Thru Cabinet

- 35) Refrigerator/Freezer
- 36) Microwave
- 37) Recessed entrance mat
- 38) Fire Sprinklers
- 39) Automatic Flush Valve
- 40) ADA Water closet
- 41) Wall Hung Lavatory
- 42) Countertop sink
- 43) Double Sink
- 44) Electric Water cooler – dual height with bottle
- 45) Wall Cleanout
- 46) Floor cleanout
- 47) Electric Water Heater – 66 gallons
- 48) Expansion tank – 2 gallon
- 49) Recirculation pump – 3 GPM
- 50) 1" CW/HW Piping
- 51) 1-1/2", 2", 2-1/2", 3", and 4" DWV Piping
- 52) Roof Top Unit – 14,000 CFM
- 53) Fan Coil Units: 500 to 999 CFM
- 54) Fan Coil Units: 1,000 to 1,499 CFM
- 55) Fan Coil Units: 1,500 to 1,999 CFM
- 56) Fan Coil Units: 2,000 to 2,499 CFM
- 57) Ductwork
- 58) Supply Registers
- 59) Return Grilles
- 60) Linear Diffusers
- 61) HVAC Controls – Large
- 62) HVAC Controls – Small
- 63) 2x2 Electrical Lights
- 64) 1x4 Electrical Lights
- 65) 6" Can Light
- 66) Decorative Lighting
- 67) Occupancy Sensors
- 68) Switches
- 69) Conduit/Wiring for Power
- 70) Panel Distributions
- 71) Sound Masking
- 72) Data Outlets for Telecommunications
- 73) Furniture Data Connections for Telecommunications
- 74) Conduit/Wiring for Telecommunications including shop drawing plans
- 75) Fire Alarm System
- 76) Security System

- 77) Plumbing Materials for Vents and Wastelines that includes fixtures, elbows, etc.
- 78) 2x2 Acoustical Tile Ceiling and Grids
- 79) Floor Mounted Partitions and Doors
- 80) Electrical Generator
- 81) 4" Full Depth Patching for Parking Lot
- 82) Pavement Marking

- E. Submit gradation for the following materials:
 - a. Aggregates
 - b. Concrete mixes
 - c. Non-shrink grout
 - d. Reinforcing for Structures
 - e. Asphalt for Full Depth Patching
- F. Submit shop drawings, submittals, specification sheet, certificates, warranties, and manufacturing installation recommendations for all products.
- G. Engineer's Selection and Approval of Materials
 - a. Where approval of Engineer for material or equipment is required, secure such approval before procurement.
 - b. Where colors and/or patterns are to be selected by Architect, request such selection in ample time for procurement.
 - c. Where Specifications include cash allowances, request Engineer to select the appropriate material in ample time for procurement.
 - d. The esthetic values of every material and installation, such as shape, proportion, texture, finish and color, will be an important consideration to Engineer and their decisions concerning same shall be final.
- H. County's Selection and Approval of Materials: Where approval of County for material or equipment is required, secure such approval before procurement.
- I. Laboratory tests of materials and equipment, which are normally conducted by the manufacturer or material supplier, and tests shall be furnished by the Contractor and approved by the County.
- J. All quality control testing not specified to be performed by the Contractor will be performed by an independent testing laboratory, selected by the Owner, or by the Owner's designee. All such tests performed by the independent testing laboratory shall be paid by the Owner.
- K. Assigning, transferring or subletting, even though consented to, shall not relieve the Contractor of his liabilities under his contract. The Contractor shall give their personal

attention to any and all portions of the contract which have been sublet and they shall be responsible for its proper construction.

- L. Receiving and Storing Materials: Remove from premises materials showing deterioration or damage and replace with new.
 - a. On receipt of materials, check for in-transit damage in ample time to replace any damaged materials prior to installation time.
 - b. Where possible, deliver materials and equipment to project site in manufacturer's original packages, keeping labels intact until final cleaning. Where items are to be job assembled label, tag, mark or otherwise properly identify each component part until incorporated in building.
 - c. Store materials in manner to prevent deterioration, staining, soiling and intrusion of foreign materials. Provide waterproof well-ventilated enclosures for material subject to deterioration by dampness. Protect materials subject to damage by freezing and frost.
 - d. Remove from premises materials showing deterioration or damage and replace with new.

- M. Equipment Verification
 - a. Contractor shall check physical sizes of all equipment furnished under this contract or furnished by Owner and require other contractors to verify sizes of their equipment, in time to allow ample room for transporting equipment to and installing in its final location before enclosing spaces for it. Notify Engineer in writing of any required openings or ceiling heights; such notice in ample time for Engineer to direct necessary adjustments before such openings, ceilings or enclosures are placed.
 - b. Before construction proceeds to point that would prevent necessary modifications, Contractor shall check Drawings, Specifications, shop drawings and change orders and notify Engineer in writing of any mechanical/electrical services and/or connections required but not indicated, or incorrectly indicated, for equipment furnished. Failing to do so, Contractor furnishing equipment provide required services and/or connections at their own expense.
 - c. Contractor shall provide to the County pictures verifications of ALL the products delivered to the HEALTH DEPARTMENT BUILDING site prior to installation.

- N. Unless Owner grants permission to repair any defective work, remove defective work from project and replace with new work in accordance with contract documents. Permission to repair such work shall not constitute a waiver of Contractor's right to require complete replacement of defective work if repair operation does not restore quality and appearance of member or surface to Owner's satisfaction. If permission is granted, repair according to Owner's directions.

- O. The Prime Contractor shall submit compliance submittals of materials furnished by subcontractors, manufacturers, and suppliers.

- P. The prime Contractor, as a condition of this contract, is responsible for assuring submission of proof or documentation regarding Affirmative Action compliance by their Subcontractors and for the subsequent Affirmative Action performance by such Subcontractors.

SC-54 DISPOSAL OF TRASH AND DEBRIS (GC-54)

The following is added to GC-54:

- A. The Contractor shall take the necessary precautions to keep aggregate, mud, debris from being deposited onto ingress/egress areas in the interior of the building, sidewalks, parking areas driveways, roadway and private entrances during construction operations. Should debris become deposited on such areas, the Contractor shall promptly remove it at no additional cost to the Owner. Debris shall be disposed of in accordance with all local codes.
- B. Keep covered materials, cavities and holes subject to damage by falling materials or deposits of water, snow or ice.
- C. Transport, handle, store and erect materials in a manner to keep from injury.
- D. Protect previously placed work by suitable coverings or other protection during installation of subsequent work. Clean off foreign materials accidentally deposited on finish surfaces and, where such would stain, corrode or otherwise disfigure, clean same immediately with material that will not damage finished work.
- E. Before the work will be accepted by the Owner, the Contractor shall be required to remove all aggregate and debris resulting from their operation, which also includes, cleaning the work area of the HEALTH DEPARTMENT BUILDING inside and outside within this contract, cleaning streets, ditches, creek, driveways of earth, sod or other objectionable material and shall dispose of such debris off the project. This cleanup shall be limited to the project limits.
- F. Where finished floors are subject to damage, suitably cover traffic areas until building acceptance.
- G. **Final Cleanup shall be at no additional cost to the Owner.**

SC-56 EQUIPMENT GUARANTY (GC-56).

The General Conditions GC-56 is amended by adding the following:

- A. Delete Section GC-56 EQUIPMENT GUARANTY. No equipment is being supplied as a part of the contract and thus a guaranty of equipment is not required.
- B. Provide temporary walks, ramps, ladders, runways, scaffolding, shoring, bracing, tarps and other equipment required for progress of work and remove such at work completion.

SC-58 PERFORMANCE, PAYMENT, AND MAINTENANCE BOND (GC-58)

Delete the first paragraph of GC-58 and replace it with the following:

- A. PERFORMANCE, LABOR AND MATERIALS BOND: The Successful Bidder will be required to submit to the Purchasing Department a Performance, Labor and Materials Payment Bond in the amount of 100% of the contract award within ten business days after Notification of Award. The bond must be in a form acceptable to the Director of Finance and Purchasing and executed by a Surety Company registered to do business in the State of Missouri and listed on the Federal Register. Bonds must be received by the Purchasing Department prior to the commencement of any work on this project.
- B. MAINTENANCE BOND: The Contractor's attention is called to paragraph "c" of GC-58, which requires a **Two-year (2-year) maintenance bond**. Contractor shall submit a Maintenance Bond to Jackson County Public Works (JCPW) upon the Final Acceptance by the County.
- C. The Final Acceptance Letter from JCPW Engineering staff member will be certified mailed to the Contractor. The Final Completion Date stated on the Final Acceptance Letter will be the start date of the Maintenance Bond. The Contractor is required to use this date on the Maintenance Bond.
- D. **The Maintenance Bond forms shall be signed and sealed prior to giving the County the original.**

SC-59 ESTIMATED QUANTITIES (GC-59)

Add the following to bottom of GC-59:

It is the intent of the contract documents that the total bid, as submitted, shall cover all work required by the contract documents. All costs in connection with the work, including furnishing of all materials, equipment, supplies and appurtenances; providing all necessary labor to fully complete the work shall be included in the unit and lump sum prices named in the bid. No item of work that is required by the contract documents for the proper and successful completion of the contract will be paid for outside of, or in addition to, the prices submitted in the bid. All such work not specifically set forth in the bid as a pay item shall be considered a **SUBSIDIARY** obligation of the Contractor and all costs in connection therewith shall be included in the prices named in the bid. On the plans, or in the specifications, certain quantities may be given which do not appear in the bid. These quantities are given for the convenience of the contractor only and are considered **SUBSIDIARY** for payment purposes as given above.

SC-60 MONTHLY ESTIMATES AND PAYMENTS (GC-60)

Modify GC-60, Monthly Estimates and Payments, by adding the following:

- a. **Owner shall retain ten percent (10%) of each partial payment until completion and acceptance of the Work covered by the Contract and final payment is due.**

- b. The method of measurement and basis of payment for each item as listed in the Bid will be as stipulated in the sections of the Technical Specifications and on the Plans and in this article.
- c. There shall be no measurement or separate payment for any item of work which is not specifically identified and listed in the Bid and all costs pertaining thereto shall be included in the contract unit prices for related items which are listed in the bid.
- d. Pay limits given in the Specifications and Plans are maximum. Where actual quantities are less than as computed by said pay limits, the Contractor will be paid only for the actual quantities.
- e. All work completed under the Contract will be measured according to United States Imperial system. The method of measurement and computations to be used in determination of quantities of material furnished and of work performed under the Contract will be those methods generally recognized as conforming to good engineering practices.
- f. All materials, which are measured or proportioned by weight, shall be weighed on platform scales furnished by the Contractor, or on public scales at the Contractor's expense. The scales shall comply with all state laws governing the use of scales and shall be tested and sealed by an authorized public official, at the expense of the Contractor, as often as the Engineer may deem it necessary to ensure their accuracy. The Contractor shall furnish the Engineer a waybill for each truckload, signed by the weigh master and truck driver.
- g. The Contractor shall maintain a running balance of weights of materials versus areas covered, furnishing this data to the County, in order that corrections for overrun or under run may be made when desired.
- h. The County will not pay for, or be responsible for, unused materials, which may have been ordered by the Contractor in accordance with the quantities listed in the bid.
- i. The Contractor shall make an approximate estimate of the value of the work done and unused materials delivered for, and stored on, the site of the work during the previous calendar month. The Contractor shall furnish to the Engineer such detailed information as requested to aid them as a guide in the review of the payment application.
- j. The Contractor shall submit payment estimates or certificates of payment to the County.

SC-62 COMPLETION AND ACCEPTANCE OF WORK (GC-62)

- A. "Substantial Completion" shall be the stage in the progress of the Work where the Work is sufficiently complete in accordance with the Contract Documents so that the Owner can occupy or utilize the Work for its intended user.
- B. The Contractor shall be responsible for the restoration of any paved, graveled, or grassed areas disturbed by construction. Any areas so affected shall be restored to a condition as nearly as possible to that existing prior to construction. Paved and graveled areas shall be resurfaced with materials meeting the requirements of the technical specifications, and grassed areas shall be seeded and mulched. No direct measurement or payment will be made for restoration of areas disturbed by the construction which are outside of the limits designated on the Drawings.

SC-63 FINAL ESTIMATE AND PAYMENT (GC-63)

General Conditions GC-63 is modified by adding the following:

- A. Contractor shall notify the County when they have completed all work in accordance with the Drawings and Specifications. Contractor shall avail themselves for an on-site inspection of the project with the Owner and the County. Any items found to be incomplete or improperly constructed shall be listed, and the Contractor shall take prompt action to correct such items. Upon completion of all such work, a final inspection will be scheduled to include the Contractor's representative, the Owner's representative, and the County. Should the Contractor fail to complete the items listed (thereby causing final inspection to be repeated), the cost of engineering or any other costs incurred by the Owner, due to such repeated inspections, shall be at the expense of the Contractor and will be deducted from the final contract amount.
- B. Finishing
 - a. Adjust doors, drawers, hardware, appliances, motors, valves, controls, and other equipment for proper operation.
 - b. Seal exterior joints between materials to form a waterproof enclosure.
 - c. Touch-up imperfections in surfaces, paint and other finishes after all sub-contractors and tradesmen have completed their work.
- C. Clean surfaces using appropriate materials and methods that will thoroughly clean but not damage materials and their finishes, nor damage or adversely affect other materials in the project.
- D. **Prior to the Final Inspection, the Contractor shall provide to Jackson County Public Works the AS-BUILTS drawings and based on any and all redlines, modifications, addition or deletions, and changes to the project.**
- E. Prior to Project Closeout and Final Payment, the Contractor shall provide to Jackson County Public Works the Operation & Maintenance Manuals for ALL material products used in this project.

SC-65 CLAIMS FOR ADJUSTMENT AND DISPUTES (GC-65)

General Conditions GC-65 is modified by adding the following:

- A. Each Contractor must form their own opinion of the character and condition of materials to be encountered from an inspection of the site and from other such investigations as they may desire to undertake.
- B. The Contractor is solely responsible for determination of existing conditions. All claims for adjustments in contract price or quantity of removals shall be denied.

SC-68 DIFFERING SITE CONDITIONS (GC-68)

The following requirement is hereby added to the contract:

- A. Prior to the beginning or during the progress of the work, if subsurface or latent physical conditions are encountered at the site differing materially from those indicated in the contract or if unknown physical conditions of an unusual nature, differing materially from those ordinarily encountered and generally recognized as inherent in the work provided for in the contract, are encountered at the site, the party discovering such conditions shall promptly notify the other party in writing of the specific differing conditions before they are disturbed and the affected work is performed.
- B. Upon written notification the County will investigate the conditions and if he/she determines that the conditions of the pavement materially differ and cause an increase or decrease in the cost or time required for the performance of any work under the contract, an adjustment will be made and the contract modified in writing accordingly. The County will notify the Contractor of their determination whether or not an adjustment of the contract is warranted.
- C. No contract adjustment, which results in a benefit to the Contractor, will be allowed unless the Contractor has provided the required written notice.

SC-69 CLEAN UP

- A. Before the work will be accepted by the Owner, the Contractor shall be required to remove all aggregate and debris resulting from operations, which also includes cleaning streets, ditches creeks, and driveways of earth, sod or other objectionable material and shall dispose of such debris off the project. This cleanup shall be limited to the project limits.
- B. Contractor's clean up shall include wiping down exposed surfaces, washing bathroom floors, washing stairwells and landings, wiping down all dispensers, windows, and vacuuming or thoroughly sweeping floors.
- C. Final Cleanup shall be at no additional cost to the Owner.

SC-70 SURFACE RESTORATION

The Contractor shall be responsible for the restoration of any paved, graveled, or grassed areas disturbed by construction. Any areas so affected shall be restored to a condition as nearly as possible to that existing prior to construction. Paved and graveled areas shall be resurfaced with materials meeting the requirements of the technical specifications, and grassed areas shall be seeded and mulched. No direct measurement or payment will be made for restoration of areas disturbed by the construction which are outside of the limits designated on the Drawings.

SC-71 SUBSTANTIAL COMPLETION

“Substantial Completion” shall be the stage in the progress of the Work where the Work is sufficiently complete in accordance with the Contract Documents so that the Owner can occupy or utilize the Work for its intended user.

SC-72 SAFETY TRAINING REQUIREMENTS FOR ALL ON-SITE PERSONNEL

The Contractor to whom the contract is awarded and any subcontractor under such contractor shall require all on-site personnel to complete a ten-hour Occupational Safety and Health Administration (OSHA) construction safety program for their on-site personnel which includes a course in construction safety and health approved by OSHA or a similar program approved by the department which is at least as stringent as an approved OSHA program. All personnel are required to complete the program within sixty days of beginning work on such construction project. The Contractor shall provide certification of compliance with this condition following the award of the contract and before work commences on the project. Copies of the minimum OSHA 10 Cards shall be provided to Jackson County, MO. to be reviewed by the JCMO Compliance Office. The requirement is that before anyone is allowed to work on the project, their OSHA 10 minimum certification cards must have been submitted to the County. This includes subcontractors that will be working on the site. It does not include suppliers or truck drivers. Personal Protective Equipment (PPE) per OSHA requirements shall be followed for this project.

SP-73 CONTRACTOR LICENSE REQUIREMENTS

As of January 28, 2014 all work defined in Chapter 54 of the Jackson County Code as electrical work, mechanical work, or plumbing work must be performed by a person holding a Class A or B or C License. See Appendix for application and additional requirements.

END OF SECTION

PUBLIC WORKS TECHNICAL SPECIFICATIONS

TS-1 EMERGENCY PROVISIONS AND INCIDENT MANAGEMENT

- A. The Contractor shall have communication equipment on the construction site or immediate access to other communication systems to request assistance from the police or other emergency agencies for incident management. In case of traffic accidents or the need for police to direct or restore traffic flow, the Contractor shall notify the Sheriff's Office or other emergency agencies immediately as needed. The County shall also be notified when the Contractor requests emergency assistance.
- B. In addition to the 911 emergency telephone number for ambulance, fire, or police services, the following agencies may also be notified for accident or emergency situation with the project limits.
- a. Sheriff's Office: 816-541-8017
 - b. Lee's Summit Police Department: 816-969-1700
 - c. Lee's Summit Fire Department: 816-969-1300

This list is not inclusive. Notification of the need for wrecker or tow truck services will remain the responsibility of the appropriate police agency. The Contractor shall notify enforcement and emergency agencies before the start of construction to request their cooperation and to provide coordination of services when emergencies arise during the construction at the project site. When the Contractor completes this notification with enforcement and emergency agencies, a report shall be furnished to the County on the status of incident management.

- C. No direct pay will be made to the Contractor to recover the cost of the communication equipment, labor, materials or time required to fulfill the above provisions.

TS-2 GENERAL

- A. Contract Specifications: The detailed specifications, which follow shall govern the materials furnished and work performed in the construction of the work covered by this contract. No attempt has been made in the foregoing designated specifications to segregate work to be performed by any trade, subcontract, or bid item, under any one section of the specifications.
- B. Any segregation between trade or craft jurisdiction limits, and the establishment of subcontract limits, will be solely a matter of agreement between the Contractor and their personnel and their Subcontractors. The specifications will govern the construction of the entire work, and the provisions thereof shall govern each item and unit of work to which such provisions apply.
- C. The latest editions of the following specifications are incorporated into the Contract Documents by reference:
- The "Missouri Standard Specifications for Highway Construction", 2022 edition plus quarterly supplements as published by the Missouri Department of Transportation (MoDOT) are hereby incorporated into the Contract Documents
 - "Standard Specifications and Design Criteria", Current Edition as published by the Kansas City Metropolitan Chapter of the American Public Works Association (APWA)

- 2009 International Building Code published by the International Code Council
 - 2009 Uniform Plumbing Code
 - 2009 International Mechanical Code
 - 2008 National Electrical Code published by the International Code Council
 - 2009 International Uniform Fire Code published by the International Code Council
 - 2009 International Existing Building Code
 - 2003 ICC/ANSI A117.1 Accessibility Code
 - Federal Highway Administration, Manual on Uniform Traffic Control Devices (MUTCD), current edition.
- D. Technical Specifications for the work shall consist of the above referenced specifications with such revisions, amendments, and supplements as are contained herein. The work shall be constructed in accordance with these technical specifications and any attached plans or drawings. Any omission found in these Technical Specifications, and/or the appropriate Standard Specification, shall govern the plans where applicable sections in the Standard Specifications are found.
- E. Applicable Codes and Standards: Where referred to in the technical specifications or plans, portions of organizations' specifications are incorporated into the Contract. Wherever a part of any standard specification (ASTM, AASHTO, etc.) is referred to in the technical specifications or plans, the following conditions shall apply unless otherwise provided in the technical specifications or plans:
- Only the specifically referred to part of the standard specification shall apply to this Contract. Whenever any provision of a standard specification conflicts with any of the Contract Documents, said Contract Documents shall govern.
- F. Construction Testing: All sampling and testing deemed necessary by the County to determine if materials or methods are in compliance with the specifications shall be performed by a testing laboratory selected by the County. The cost of all such tests showing compliance with the specifications shall be paid by the County unless otherwise noted in the technical specifications. In the event that any test indicates non-compliance with specifications, at least one (1) additional test will be paid for by the Contractor to determine acceptability of material or methods. All documentation verifying compliance shall be submitted to the County for compliance review.
- G. Construction Schedule: Before work is started, the Contractor shall prepare a detailed schedule of all construction operations that shall indicate the sequence of the work and also the time of starting and completing each part. The schedule shall be submitted to the County for their approval.
- H. Losses From Natural Causes: All loss or damage arising out of the nature of the work to be done, or from the action of the elements, or from floods or overflows, or from ground water, or from unusual obstructions or difficulties, or any other natural or existing circumstances either known or unforeseen, which may be encountered in the prosecution of the said work shall be sustained and borne by the Contractor at their own cost and expense.
- I. Unfavorable Construction Conditions: During unfavorable weather, or other unfavorable

conditions for construction operations, the Contractor shall pursue only such portions of the work as will not be damaged thereby. No portions of the work, the satisfactory quality or efficiency of which will be affected by any unfavorable conditions, shall be constructed while these conditions exist, unless by special means or precautions approved by County, the Contractor shall be able to perform the work in a proper and satisfactory manner.

- J. Protection and Maintenance of Public and Private Property: All existing underground utilities shown in the Plans were provided by each utility company. Before starting work, the Contractor shall notify all utilities involved, and shall request them for cooperation in locating lines in advance of the work. The Contractor shall make reasonable effort to avoid breaking utility lines. The utility shall be notified immediately should a break occur in a line during construction under this Contract.
- K. Any lines that are broken by the Contractor shall be repaired according to the utility company's standards at the expense of the Contractor. Wherever the work is along existing pavement which is to be retained, traction equipment with lugs will not be permitted. The Contractor shall use utmost care not to damage or destroy any existing pavement. Any pavement damaged or destroyed due to the operations of the Contractor, which is not within the construction limits shall be replaced in accordance with these specifications.
- L. The Contractor shall be held responsible for all damage to buildings, roads, highways, shoulders, ditches, bridges, and other property, caused by them or their subcontractors in transporting materials to or from the site of work, regardless of location of such damage, and shall pay for or place such damaged property to the satisfaction of the owner of such property.
- M. Clearing and Cleaning Up: The Contractor shall do all necessary clearing and demolition work prior to excavation for the proposed construction. The Contractor shall not allow the site of the work to become littered with trash and waste material but shall maintain same in a neat and orderly condition during the process of the work to completion. The Contractor shall clean up all dirt from building, paved surfaces, not allow same to pack on the roadway or create a traffic nuisance.

TS-3 UTILITIES

- A. Description: For informational purposes only, the following is a list of names, addresses, and telephone numbers of the known utility companies in the area for the construction work for this project.

<u>Utility Name</u>	<u>Known Required Adjustment</u>
Evergy 1105 E 40 Highway Blue Springs, MO 64014 Janet Waddell (816) 729-5128 Michelle Arps (816) 769-4765	No Adjustment.
AT&T 2121 E. 63 rd Street Kansas City, MO 64130 Ron Gipfert (816) 772-0318	No Adjustment

Southwestern Bell Telephone No Adjustment
215 N. Spring 2nd Floor
Independence, MO 64050
Steven Smith (816) 325-6527

Comcast No Adjustment
4700 Little Blue Parkway
Independence, MO 64057
Andrew Bell (816) 795-2255

Spire Energy No Adjustment
3025 SE Clover Drive
Lee's Summit, MO 64082
Katelynn Liberty (816) 260-6581

City of Lee's Summit Water Department No Adjustment
220 SE Green St.
Lee's Summit, MO 64063
Judy Niemeyer (816) 969-1800

- B. The existence and approximate location of the utility facilities known to exist, as shown on the Plans, are based upon the best information available to the County at this time. This information is provided by the County and the County expressly disclaims any representation or warranty as to the completeness, accuracy, or suitability of the information for any use. Reliance upon this information is done at the risk and peril of the user, and the County shall not be liable for any damages that may arise from any error in the information. It is, therefore, the responsibility of the Contractor to verify the list above indicating existence, location, and status of any facility. Such verification includes direct contact with the listed utilities.
- C. The Contractor agrees that any effects of the presence of the utilities, their relocation, Contractor's coordination of work with the utilities and any delay in utility relocation shall not be compensable as a suspension of work, extra work, a change in work, as a differing site condition or otherwise including but, without limitation, delay, impact, incidental or consequential damages. The Contractor's sole remedy for the effects of the presence of utilities, delay in their relocation or any other effects shall be an excusable delay provided Contractor notifies the County in writing of the delay at the time it occurs. The Contractor waives, for itself, its subcontractors and suppliers the compensability of the presence of utilities, delay in their relocation and any cost to the Contractor, its subcontractors and suppliers in any claim or action arising out of or in relation to the work under the Contract.
- D. The Contractor shall be solely responsible and liable for incidental and consequential damage to any utility facilities or interruption of the service caused by it or its subcontractors operation. The Contractor shall hold and save harmless the County from damages to any utility facilities interruption of service by it or its subcontractors operation.
- E. The Contractor shall coordinate their operations with the work of utility owners making necessary adjustments, removals, or construction of new fixtures, and shall permit free access to the site for such work.
- F. It is understood and agreed that the Contractor has considered in their bid all of the permanent

and temporary utility appurtenances in their present or relocated positions whether or not shown on the Plans and that no additional compensation will be allowed for any delays, inconvenience, or damage sustained by them due to any interference from the said utility appurtenances or the operation of moving them.

- G. The general location of railroad facilities, of principal water mains, sewer pipes, telephone conduits, gas mains, pipe lines, pole lines, and other public and private utility facilities which will affect construction operations are indicated on the Plans based on One-Call utility locates. Some of these utilities may remain in place; others may be removed entirely or in part by the facility owners for relocation elsewhere.
- H. When the failure of the facility owners to cooperate and coordinate their work with that of the Contractor results in actual delay to the Contractor in the over-all completion of their work, such delay will be considered in the count of construction days or date specified for completion, provided the Contractor notifies the County's Representative in writing of the delay at the time it occurs.
- I. Should there be located within the right-of-way any public or private utility facilities which are to remain in place and which will interfere with the Contractor's proposed operation, the Contractor shall make all necessary arrangements with the facility owners for any temporary or permanent removal or relocation of such facilities desired for their convenience. Any cost involved shall be borne by the Contractor.
- J. The Contractor shall use every precaution necessary to prevent damage to all public and private utility wires, lines, pipes, poles, cables, and conduits within the right-of-way. The Contractor shall be responsible for all damage to any utility facility due directly to their operations regardless of location and they shall repair and replace as necessary any such damaged facility or make payment to the facility owner for repair or replacement. See cover sheet of Plans for list of utility companies and contact information.
- K. No direct pay will be made to the Contractor to recover the cost of coordination with the utility companies. All costs pertaining to this item shall be included in the contract prices of other items.
- L. Care should be taken when removing trees that intertwine with the overhead lines. DO NOT DAMAGE.

TS-4 PROTECTION OF PROPERTY

- A. The Contractor shall protect existing public and private property from damage by construction operations.
 - a. Confine all work, equipment, and personnel within the limits of the project right-of-way and easements shown on the Plans.
 - b. Take all precautions required to preserve and protect all existing trees, shrubs, and other improvements located within the project right-of-way and easements, except those items designated to be removed.
 - c. Where fences are to be breached on private property, the property owners shall be contacted and arrangements made to ensure proper protection of any property and livestock exposed

- to the open condition.
- d. Before acceptance of the Work by County, Contractor shall replace or repair all existing improvements damaged by their operations. This shall include, but not be limited to; damage to existing pavement beyond the immediate project limits, side roads, curbs, and entrances.
 - e. All property pins removed or displaced shall be reset to its original location by a licensed Surveyor registered in the State of Missouri.
- B. No separate payment will be made for the protection of property. All costs pertaining to this item shall be included in the contract prices of other items

TS-5 JOB SITE ADMINISTRATION

- A. The Contractor shall give the Work the constant attention necessary to facilitate the progress thereof, and shall cooperate with the County and other contractors in every way possible.
- B. The Contractor shall have on the work site at all times, as their agent, a competent superintendent capable of reading and thoroughly understanding the plans and Specifications and thoroughly experienced in the type of work being performed, who shall receive instructions from the County. The superintendent shall have full authority to execute orders or directions of the County without delay, and to promptly supply such materials, equipment, tools, labor, and incidentals as may be required. Such superintendence shall be furnished regardless of the quantity of work sublet.
- C. The Superintendent shall not be removed or replaced without prior written consent of the Owner.
- D. No separate payment will be made for job site administration. All costs pertaining thereto shall be included in the contract prices for other items.

TS-6 PRECONSTRUCTION MEETING

- A. Prior to starting work, a preconstruction conference will be held to discuss the project, its scheduling and its coordination with the work of others. It is expected that this conference will be attended by representatives of the County, the Contractor, and their subcontractors, utility representatives, as well as representatives of any other affected agencies that the County may wish to invite. The Contractor shall bring to the conference a tentative schedule of construction progress, shop drawing submittals and other required submittals and certifications. Discussion items of significance that could affect project progress may include the following:

- a. Tentative construction schedule.
 - b. Critical work sequencing.
 - c. Coordination with the County.
 - d. Designation of responsible personnel.
 - e. Procedures for processing field decisions and change orders.
 - f. Procedures for processing Applications for Payment.
 - g. Distribution of contract documents.
 - h. Submittal of shop drawings and product data.
 - i. Preparation of record documents.
 - j. Use of the premises.
 - k. Working hours.
- B. The County will schedule a Preconstruction Conference at location to be determined, no later than 20 days after the effective date of the Agreement and prior to commencement of construction activities. The County will conduct the meeting to review responsibilities and personnel assignments.
- C. Attendees will include representative from the County, the Contractor, subcontractors, manufacturers, suppliers, utility companies, and other concerned parties shall be represented at the conference by persons familiar with and authorized to conclude matters relating to the Work.
- D. The agenda will review items of significance that could affect progress, including topics such as the following:
- a. Introduction of attendees.
 - b. Distribution of Contract Documents.
 - c. Designation of responsible personnel.
 - d. Tentative construction schedule, including critical work sequencing.
 - e. Critical work sequencing.
 - f. Designation of responsible personnel.
 - g. Coordination with County.
 - h. Submittal of certified payrolls, wage interviews, and compliance with minority participation.
 - i. Procedures for processing field decisions and change orders.
 - j. Submittal of shop drawings and product data.
 - k. Procedures for processing Applications for Payment.
 - l. Distribution of contract documents.
 - m. Preparation of record documents by the Contractor.
 - n. Use of the premises (right-of-way and easements)ay and easements).
 - o. Working hours and holidays.
- E. No separate payment will be made for the preparation, attendance of the preconstruction meeting, or maintenance of the construction schedule. All costs pertaining to this item shall be included in the contract prices of other items.

TS-8 SUBMITTALS

- A. General: The Contractor is required to provide documentation for the performance of the Work. These submittals are divided into administrative and procedural categories. They

include, but are limited to the following:

- a. Administrative Submittals
 - 1. Permits
 - 2. Applications for payment
 - 3. Performance and maintenance bonds
 - 4. Insurance certificates
 - 5. List of approved subcontractors
 - 6. M/W/VBE compliance
 - 7. OSHA 10 Cards
 - 8. Certified payrolls (Contractor and subcontractors)
- b. Procedural Submittals
 - 1. Contractor's project schedule
 - 2. Shop drawings
 - 3. Product data certifications

B. Submittal Procedures:

- a. Coordinate preparation and processing of submittals with performance or construction activities. Transmit each submittal sufficiently in advance of performance of related construction activities to avoid delay.

Coordinate each submittal with fabrication, purchasing, testing of submittals for related activities that require sequential activity.

Coordinate transmittal of difference types of submittals for related elements of the Work so processing will not be delayed by the need to review submittals concurrently for coordination.

The County reserves the right to withhold action on a submittal requiring coordination with other submittals until related submittals are received.

- b. Processing: Allow sufficient review time so that installation will not be delayed as a result of the time required to process submittals, including time for resubmittals.
 - 1. Allow two (2) weeks for initial review. Allow additional time if processing must be delayed to permit coordination with subsequent submittals. The County will promptly advise the Contractor when a submittal being processed must be delayed for coordination.
 - 2. If an intermediate submittal is necessary, process the same as the initial submittal.
 - 3. Allow two (2) weeks for reprocessing each submittal.
 - 4. No extension of Contract Time will be authorized because of failure to transmit submittals to the County sufficiently in advance of the Work to permit processing.
- c. Submittal Transmittal: Package each submittal appropriately for transmittal and handling. The transmittal form should have the following information. Submittals received from sources other than the Contractor will be returned without action.

1. Project name
 2. Project number
 3. Date
 4. Name and address of contractor
 5. Name and address of subcontractor (if needed)
 6. Name and address of supplier/manufacturere
 7. Number and title of appropriate specification section
 8. Drawing number and detail reference
- C. Shop Drawings: Submit newly prepared information drawn to accurate scale. Highlight, encircle, or otherwise indicate deviations from the Contract Documents. Do not reproduce Contract Documents or copy standard information as the basis of Shop Drawings. Standard information prepared without specific reference to the Project is not considered a Shop Drawing. The Contractor shall not use any Shop Drawing without an appropriate final stamp indicating action taken in connection with construction.
- a. Shop Drawings include fabrication and installation drawings, layout drawings for reinforcing steel, falsework/forms, schedules, patterns, templates, and similar drawings. Include the following information:
 1. Dimensions
 2. Identification of products and materials included
 3. Compliance with specified standards
 4. Notation of coordination requirements
 5. Notation of dimensions established by field measurement
 - b. Sheet Size: except for templates, patterns, and similar full-size drawings, submit Shop Drawings on sheets at least 8-1/2" x 11" but no larger than 22" x 34".
 - c. Quantity Requirements: Except as otherwise specified, transmit six (6) copies all manufacturer's or fabricator's Shop Drawings to the County. Three (3) copies will be returned to Contractor.
 - d. Construction Record Drawings: The Contractor shall supply one full size (34" x 22") and one half size (17" x 11") AS-Built Construction Plans that includes AS-Built Surveyed drawings and electronic PDF (Portable Document Format) and AutoCadd drawings, current version, to the County. The AS-Built Construction Plans shall be provide to the County upon the completion of the construction project.
- D. Product Data: Collect Product Data into a single submittal for each element of construction or system. Product Data includes printed information such as manufacturer's installation instructions, catalog cuts, standard color charts, roughing-in diagrams and templates, standard wiring diagrams, and performance curves. Where Product Data must be specially prepared because standard printed data is not suitable for use, submit as "Shop Drawings."
- a. Mark each copy to show applicable choices and options. Where printed Product Data includes information on several products, some of which are not required, mark copies to indicate the applicable information. Include the following information:

1. Manufacturer's printed recommendations
 2. Compliance with recognized testing agency standards
 3. Application of testing agency labels and seals
 4. Notation of dimensions verified by field measurement
 5. Notation of coordination requirements
- b. Do not submit Product Data until compliance with requirements of the Contract Documents has been confirmed.
- c. Quantity Requirements: Except as otherwise specified, transmit six (6) copies all submittals of product data to the County. Three (3) copies will be returned to Contractor.
- d. Distribution: Furnish copies of final submittal to installers, Subcontractors, suppliers, manufacturers, fabricators, and others required for performance of construction activities. Show distribution on transmittal forms.
1. Do not proceed with installation until an approved copy of the applicable Product Data is in the installer's possession.
 2. Do not permit use of unmarked copies of Product Data in connection with construction.
- E. County's Action: Except for submittals for record, information, or similar purposes where action and return is required or requested, the County will review each submittal, mark to indicate action taken, and return promptly. Compliance with specified characteristics is the Contractor's responsibility.
- a. Action Stamp: The County will stamp each submittal with a uniform, self-explanatory action stamp. The stamp will be appropriately marked, as follows, to indicate the action taken:
1. Approved: Where submittals are marked "Approved", that part of the Work covered by the submittal may proceed provided it complies with requirements of the Contract Documents; final acceptance will depend upon that compliance.
 2. Approved As Noted: When submittals are marked "Approved as Noted", that part of the Work covered by the submittal may proceed provided it complies with notations or corrections on the submittal and requirements of the Contract Documents; final acceptance will depend on that compliance.
 3. Revise and Resubmit: When submittals are marked "Revise and Resubmit", do not proceed with that part of the Work covered by the submittal, including purchasing, fabrication, delivery, or other activity. Revise or prepare a new submittal in accordance with the notations; resubmit without delay. Repeat, if necessary, to obtain a different action mark. Do not permit submittals marked "Revise and Resubmit" to be used at the Project site, or elsewhere where Work is in progress.
 4. Rejected: When submittals are marked "Rejected", do not proceed with that part of the Work covered by the submittal. The information provided does not comply with the parameters noted in the Plans. The submittal shall be revised to meet the design requirements and resubmitted to the County for review.
 5. Not Subject To Review: When submittals are marked "Not Subject To Review", the information provided is accepted as additional data for the files. No further action is required.
- b. Regardless of how the submittal is stamped, the review and approval neither extends

nor alters any contractual obligations of the County of the Contractor.

- F. All necessary and applicable permits shall be secured for any work contemplated on public properties before commencing any activity. In all instances the applicant agrees to perform all work in accordance with the permit and to indemnify and hold harmless the County from all liability, judgments, costs, expenses and claims growing out of damages or alleged damages, of any nature to any person to property arising out of performance or non-performance of said work or the existence of facilities and/or appurtenances thereof.
- G. No separate payment will be made for any of the submittals associated with the completion of the Work. All costs pertaining to these items shall be included in the other contract prices.
- H. After execution of contract, substitution of product brands for those named in Specifications will be considered only if (1) request is received within thirty days after contract date and request includes statement showing credit due Owner, if any, if substitution product is used, or (2) Owner requests consideration be given to substitute brands.
- I. Materials and equipment proposed for substitution shall be equal or superior to that specified in construction efficiency, utility, esthetic design, and color, as determined by Architect whose decision shall be final without further recourse. Physical size of substitute brand shall not be larger than the space provided for it. Physical size and arrangement of components shall be such that there will be provided the clearances, reach range dimensions, approach space, and maneuvering space required by the Americans with Disabilities Act Accessibility Guidelines. Requests must be accompanied by full description and technical data, in three copies, including manufacturer's name, model, catalog number, photographs or cuts, physical dimensions, capacity, load rating, operating characteristics, and other information necessary for comparison.
- J. In proposing a substitution prior to or subsequent to receipt of bids, Contractor shall include in such proposal the cost of altering other elements of the project, including adjustments in mechanical-electrical service requirements, as necessary to accommodate such substitution; whether such affected elements be under his contract or under separate contracts.
- K. In preparing bid, Contractor shall check their sources of supply verifying catalog numbers and availability of materials and equipment specified. If later, any materials or equipment are discovered to be discontinued, unavailable or their catalog numbers have been changed, are incorrect or ambiguous, Contractor shall consult Owner and, without an increase in contract sum, provide equivalent materials or equipment as selected by Owner.
- L. Or Equal: For products specified by name and accompanied by the term "or equal," or "or approved equal," or "or approved," comply with requirements in "Comparable Products" Article to obtain approval for use of an unnamed product.
 - a. Conditions for Consideration: Architect will consider Contractor's request for comparable product when the following conditions are satisfied. If the following conditions are not satisfied, Architect may return requests without action, except to record noncompliance with these requirements:
 - i. Evidence that the proposed product does not require revisions to the Contract Documents, that it is consistent with the Contract Documents and will produce the indicated results, and that it is compatible with other portions of the Work.
 - ii. Detailed comparison of significant qualities of proposed product with those named in the Specifications. Significant qualities include attributes such as performance, weight, size, durability, visual effect, and specific

- features and requirements indicated.
 - iii. Evidence that proposed product provides specified warranty.
 - iv. List of similar installations for completed projects with project names and addresses and names and addresses of architects and owners, if requested.
 - v. Samples, if requested.
- M. In preparing bid, if the Contractor encounters any redundancy or needs clarifications of products within the Specifications, then the Contractor shall send all questions or request for clarification electronically through the Bonfire Portal via the Opportunity Q & A on the Invitation to Bid as per the Question Procedure outlined in Section 2.0, Page 3 of this document.
- N. Unless a delay is caused in whole, or in part, by acts or omissions within the control of the Owner or persons acting on behalf thereof (other than the Contractor or persons acting on behalf of the Contractor), the only remedy available to the Contractor for a delay shall be an extension of time. Unless a delay is caused in whole, or in part, by acts or omissions within the control of the Owner or persons acting on behalf thereof (other than the Contractor or persons acting on behalf of the Contractor), the Contractor agrees that whether or not any delay shall be the basis for an extension of time, the Contractor shall have no claim against the Owner or Architect/Engineer for:
- a. An increase in the Contract Sum;
 - b. A payment or allowance of any kind for damage, loss or expense, resulting from delays;
or
 - c. Any damage, loss or expenses, resulting from interruptions, accelerations, inefficiencies or suspensions of its work.
- Nothing herein shall be construed as granting an extension of time for delays caused, in whole or in part, by the Contractor or persons acting on behalf thereof.

TS-9 QUALITY REQUIREMENTS

- A. General: The Contractor will be fully responsible for complying with the Technical Specifications, Plans and other Contract Documents and shall obtain such certificates of compliance and have such tests made as will assure full compliance. Copies of such certificates and test reports shall be furnished to the County, prior to payment of pay items.
- a. Related Sections:
 - 1. General Conditions: responsibilities of inspection, correction, removal and acceptance
 - 2. Supplemental Conditions: responsibilities of testing
 - 3. Technical Specifications: submittal procedures
 - b. References:
 - 1. American Society for Testing and Materials (ASTM): technical standards for the various materials used on the project, including testing procedures
 - 2. Federal Highway Administration (FHWA): specifications and details for traffic control and safety
 - 3. American Association of State Highway and Transportation Officials (AASHTO): guidelines, specifications, and details for roadway safety
 - 4. Missouri Department of Transportation (MoDOT): standard details, specifications, guidelines, and procedures for roadway and structures
 - 5. Kansas City Chapter of American Public Works Association (KCAPWA): standard

- details, specifications, guidelines, and procedures for roadway and structures
- c. Testing Agency: Prior to start of the Work, the County will identify the testing agency that will be used on the project from their Term & Supply Contract.
 - d. Test Reports: After each test inspection two (2) copies of the report to the County to share with the Contractor. The report shall include:
 - 1. Date issued
 - 2. Project title and number
 - 3. Name of inspector
 - 4. Date and time of sampling or inspection
 - 5. Identification of product and specifications section
 - 6. Location in the Project
 - 7. Type of test/inspection
 - 8. Date of test/inspection
 - 9. Results of test/inspection
 - 10. Conformance with Contract Documents
 - e. Certificates: When specified in individual specification sections, submit certification by the manufacturer and Contractor to the County, in quantities specified for Product Data.
 - f. Manufacturer's Instructions: When specified in individual specification sections, submit printed instructions for delivery, storage, assembly, installation, start-up, adjusting, and finishing, for the County's information. Indicate special procedures, perimeter conditions requiring special attention, and special environmental criteria required for application or installation.
 - g. Manufacturer's Field Reports: Submit reports for the County's benefit as contract administrator. Submit for information for the limited purpose of assessing conformance with information given and the design concept expressed in the contract documents.

B. Control of Installation:

- a. The Contractor shall notify the County a minimum of 48 hours prior to expected time for operations requiring inspection and laboratory testing services. Such testing, or failure to test, on the part of the County shall in no way relieve the Contractor of complete responsibility for furnishing materials and constructing the Project in accordance with all of the Contract Documents. Testing services arranged and paid by the County.
- b. Monitor quality control over suppliers, manufacturers, products, services, site conditions, and workmanship, to produce Work of specified quality.
- c. Comply with manufacturers' instructions, including each step in sequence. If manufacturer's instructions conflict with Contract Documents, request clarification from the County before proceeding.
- d. Comply with specified standards as minimum quality for the Work except where more stringent tolerances, codes, or specified requirements indicate higher standards or more precise workmanship.
- e. Have Work performed by persons qualified to produce required and specified quality.
- f. Verify that field measurements are as indicated on shop drawings or as instructed by the

manufacturer. Once installed, secure products in place with positive anchorage devices designed and sized to withstand stresses, vibration, physical distortion, and disfigurement.

C. Certificates of Compliance:

- a. The Contractor, prior to payment for the pay items, shall submit, in triplicate, certificate of compliance from manufacturers, producers, fabricators and suppliers of items to be incorporated in the work attesting that all items and materials supplied in connection with the work conform to the requirements of the Specifications, as provided in the various sections of these Contract Documents.
- b. Whenever the items so certified deviate from the requirements of the Technical Specifications, Plans and other Contract Documents, then the Contractor shall point out such deviation in the letter of transmittal. Unless this procedure is followed and such deviations are specifically approved by the County in writing, then the County's approval of such certifications will not constitute approval of the deviations.
- c. Said certificates may be accepted by the County as adequate evidence of compliance with the Contract Documents. However, at its option, the County may test any or all of said items for compliance. If found to be in compliance with the Contract Documents, the cost of testing will be borne by the County. If found to be not in compliance, the Contractor shall pay for such testing.

D. Payment for testing shall be paid by the County in conformance with the Special Conditions. Retesting required because of non-conformance to specified requirements shall be performed by the same testing firm on instructions by the County. The Contractor shall bear all costs from such retesting at no additional cost to the County.

TS-10 TEMPORARY FACILITIES AND CONTROLS

- A. General: Installation and removal of and use charges for temporary facilities shall be included in the Contract Sum unless otherwise indicated. Allow other entities to use temporary services and facilities without cost, including, but not limited to, Owner's construction forces, Architect, testing agencies, and authorities having jurisdiction.
- B. Delivery of Temporary Facilities and Construction items: The Jackson County Health Department building has an Equipment Elevator available for deliveries by the contractor. The footprint of the Equipment Elevator cab is X.X' width x X' deep x X' Tall.
- C. Water: Any water required to prepare concrete, mortar, for the project, or other construction products shall be from a potable source. Water from a stream, pond, etc. is unacceptable. Water from Owner's existing water system is available for use without metering and without payment of use charges. Provide connections, backflow protection and extensions of services as required for construction operations.
- D. Electrical Power Service from Existing System: All power for lighting, operations of the Contractor's equipment, or for any other use which may be required for proper completion of the Work shall be provided by the Contractor. Electric power from Owner's existing system is available for use without metering and without payment of use charges. Provide connections

and extensions of services as required for construction operations. Electric Service: Comply with NECA, NEMA, and UL standards and regulations for temporary electric service. Install service to comply with NFPA 70.

- E. Sanitary Facilities: Contractor shall furnish temporary sanitary facilities at the site, as provided herein, for the needs of all construction workers and others performing work or furnishing services on the Project.

Sanitary facilities shall be of reasonable capacity, properly maintained throughout the construction period, and obscured from public view to the greatest practical extent. If toilets of the chemically treated type are used, at least one toilet will be furnished for each 20 persons. Contractor shall enforce the use of such sanitary facilities by all personnel at the site.

- F. Site Plan: Show temporary facilities, utility hookups, staging areas, and parking areas for construction personnel.
- G. Fire-Safety Program: Show compliance with requirements of NFPA 241 and authorities having jurisdiction. Indicate Contractor personnel responsible for management of fire prevention program.
- H. Tests and Inspections: Arrange for authorities having jurisdiction to test and inspect each temporary utility before use. Obtain required certifications and permits.
- I. Temporary Use of Permanent Facilities: Engage Installer of each permanent service to assume responsibility for operation, maintenance, and protection of each permanent service during its use as a construction facility before Owner's acceptance, regardless of previously assigned responsibilities.
- J. Field Offices, General: Use interior space approved by the Owner. Common-Use Field Office: Of sufficient size to accommodate needs of Owner, Architect and construction personnel office activities and to accommodate Project meetings. Keep office clean and orderly. Storage and Fabrication Sheds: None allowed on site. Use interior space as approved by the Owner only as necessary. Provide for temporary offices within construction area. Maintain support facilities until Architect schedules Substantial Completion inspection. Remove before Substantial Completion. Personnel remaining after Substantial Completion will be permitted to use permanent facilities, under conditions acceptable to Owner.
- K. Fire Extinguishers: Portable, UL rated; with class and extinguishing agent as required by locations and classes of fire exposures.
- L. HVAC Equipment: Unless Owner authorizes, provide vented, self-contained, liquid-propane gas or fuel-oil heaters with individual space thermostatic control. 1. Use of gasoline-burning space heaters, open-flame heaters, or salamander-type heating units is prohibited. 2. Heating Units: Listed and labeled for type of fuel being consumed, by a qualified testing agency acceptable to authorities having jurisdiction, and marked for intended location and application.

M. TEMPORARY UTILITY INSTALLATION

- a. General: Install temporary service or connect to existing service.
 - i. Arrange with utility company and Owner for time when service can be interrupted, if necessary, to make connections for temporary services.
 - b. Sewers and Drainage: Provide temporary utilities to remove effluent lawfully.
 - i. Connect temporary sewers to municipal system as directed by authorities having jurisdiction.
 - c. Water Service: Connect to Owner's existing water service facilities. Clean and maintain water service facilities in a condition acceptable to Owner. At Substantial Completion, restore these facilities to condition existing before initial use.
 - d. Sanitary Facilities: Provide temporary toilets, wash facilities, and drinking water for use of construction personnel. Comply with requirements of authorities having jurisdiction for type, number, location, operation, and maintenance of fixtures and facilities.
 - e. Heating and Cooling: Provide temporary heating and cooling required by construction activities for protecting existing construction from adverse effects of low temperatures or high humidity. Select equipment that will not have a harmful effect on completed installations or elements being installed.
 - f. Ventilation and Humidity Control: Provide temporary ventilation as required by construction activities for protecting existing construction from adverse effects of high humidity. Select equipment that will not have a harmful effect on completed installations or elements being installed. Coordinate ventilation requirements to produce ambient condition required and minimize energy consumption.
 - g. Electric Power Service: Connect to Owner's existing electric power service. Maintain equipment in a condition acceptable to Owner.
 - h. Lighting: Provide temporary lighting with local switching that provides adequate illumination for construction operations, observations, inspections, and traffic conditions.
 - i. Install and operate temporary lighting that fulfills security and protection requirements without operating entire system.
 - i. Telephone Service: Provide temporary telephone service in common-use facilities for use by all construction personnel. Install one telephone line(s) for each field office.
 - i. Provide additional telephone lines for the following:
 - a. Provide a dedicated telephone line for each facsimile machine in each field office.
 - ii. At each telephone, post a list of important telephone numbers. a. Police and fire departments. b. Ambulance service. c. Contractor's home office. d. Contractor's emergency after-hours telephone number. e. Architect's office. f. Engineers' offices. g. Owner's office. h. Principal subcontractors' field and home offices.
 - iii. Provide superintendent with cellular telephone or portable two-way radio for use when away from field office.
- N. Fences: All existing fences affected by the Work shall be maintained by Contractor until completion of the Work. Where fences must be maintained across the construction easement, adequate gates shall be installed. Gates shall be kept closed and locked at all times when not in use.

On completion of the Work across any tract of land, Contractor shall restore all fences to their original or to better condition and to their original location.

- O. Traffic Controls: Comply with requirements of authorities having jurisdiction. Protect existing site improvements including curbs, pavement, and utilities. Maintain access for fire-fighting equipment and access to fire hydrants.
- P. Parking: Contractor shall provide and maintain suitable parking areas for the use of all construction workers and others performing work or furnishing services in connection with the Project, as required to avoid any need for parking personal vehicles where they may interfere with public traffic, County's operations, or construction activities. Provide temporary parking areas for construction personnel. City and County Public parking lots two blocks north and south of project site are available for use by construction personnel. The County will have portions of Parking Lot of the Health Department building for the contractor's crew and equipment. Also, the County will have an area on the 1st Floor of the building. The locations will be discussed at the Pre-construction meeting to the contract award contractor.
- Q. Noise Control: Contractor shall take reasonable measures to avoid unnecessary noise. Such measures shall be appropriate for the normal ambient sound levels in the area during working hours. All construction machinery and vehicles shall be equipped with practical sound-muffling devices, and operated in a manner to cause the least noise consistent with efficient performance of the Work.

Construction activities, such as excavation, demolition, installation, erection, alteration, or repairs, adjacent to residential areas shall be limited to 7:00 a.m. and 6:00 p.m. on weekdays. In the case of urgent necessity in the interest of public safety, the Contractor may request a letter of permission from the County.

- R. Dewatering Facilities and Drains: Comply with requirements of authorities having jurisdiction. Maintain Project site, excavations, and construction free of water.
 - a. Dispose of rainwater in a lawful manner that will not result in flooding Project or adjoining properties or endanger permanent Work or temporary facilities.
 - b. Remove snow and ice as required to minimize accumulations.
- S. Waste Disposal Facilities: Provide waste-collection containers in sizes adequate to handle waste from construction operations. Comply with requirements of authorities having jurisdiction. Waste Disposal Facilities shall be removed from project site on days indicated by City and/or County for full use of site and surrounding parking.
- T. Lifts and Hoists: Provide facilities necessary for hoisting materials and personnel. Truck cranes and similar devices used for hoisting materials are considered "tools and equipment" and not temporary facilities.
- U. Existing Stair Usage: Use of Owner's existing stairs will be permitted, provided stairs are protected, cleaned and maintained in a condition acceptable to Owner. At Substantial Completion, restore stairs to condition existing before initial use.
 - a. Provide protective coverings, barriers, devices, signs, or other procedures to protect stairs and to maintain means of egress. If stairs become damaged, restore damaged areas so no evidence remains of correction work.

V. Temporary Use of Permanent and/or Restored Stairs: Use of permanent and/or restored stairs for construction traffic will be permitted, provided stairs are protected and finishes restored to new condition at time of Substantial Completion.

W. SECURITY AND PROTECTION FACILITIES INSTALLATION

- a. Protection of Existing Facilities: Protect existing vegetation, equipment, structures, utilities, and other improvements at Project site and on adjacent properties, except those indicated to be removed or altered. Repair damage to existing facilities.
- b. Environmental Protection: Provide protection, operate temporary facilities, and conduct construction as required to comply with environmental regulations and that minimize possible air, waterway, and subsoil contamination or pollution or other undesirable effects.
- c. Pest Control: Engage pest-control service to recommend practices to minimize attraction and harboring of rodents, roaches, and other pests and to perform extermination and control procedures at regular intervals so Project will be free of pests and their residues at Substantial Completion. Perform control operations lawfully, using environmentally safe materials.
- d. Barricades, Warning Signs, and Lights: Comply with requirements of authorities having jurisdiction for erecting structurally adequate barricades, including warning signs and lighting.
- e. Temporary Enclosures: Provide temporary enclosures for protection of construction, in progress and completed, from exposure, foul weather, other construction operations, and similar activities. Provide temporary weather-tight enclosure for building exterior. 1. Where heating or cooling is needed and permanent enclosure is not complete, insulate temporary enclosures.
- f. Temporary Partitions: Provide floor-to-ceiling dustproof partitions, as necessary, to limit dust and dirt migration into preservation zones such as the offices and lab room.
 - i. Construct dustproof partitions with two layers of 6-mil (0.14-mm) polyethylene sheet on each side. Cover floor with two layers of 6-mil (0.14-mm) polyethylene sheet, extending sheets 18 inches (460 mm) up the sidewalls. Overlap and tape full length of joints. Cover floor with fire-retardant-treated plywood.
 - ii. Protect air-handling equipment.
 - iii. Provide walk-off mats at each entrance through temporary partition.
- g. Temporary Fire Protection: Install and maintain temporary fire-protection facilities of types needed to protect against reasonably predictable and controllable fire losses. Comply with NFPA 241; manage fire prevention program.
 - i. Prohibit smoking at Project site.
 - ii. Supervise welding operations, combustion-type temporary heating units, and similar sources of fire ignition according to requirements of authorities having jurisdiction.
 - iii. Develop and supervise an overall fire-prevention and -protection program for personnel at Project site. Review needs with local fire department and establish procedures to be followed. Instruct personnel in methods and procedures. Post warnings and information.
 - iv. Provide temporary standpipes and hoses for fire protection. Hang hoses with a warning sign stating that hoses are for fire-protection purposes only

and are not to be removed. Match hose size with outlet size and equip with suitable nozzles.

X. MOISTURE AND MOLD CONTROL

- a. Contractor's Moisture Protection Plan: Avoid trapping water in finished work. Document visible signs of mold that may appear during construction.
- b. Controlled Construction Phase of Construction: After completing and sealing of the building enclosure but prior to the full operation of permanent HVAC systems, maintain as follows:
 - i. Control moisture and humidity inside building by maintaining effective dry-in conditions.
 - ii. Remove materials that cannot be completely restored to their manufactured moisture level within 48 hours.

Y. OPERATION, TERMINATION, AND REMOVAL

- a. Supervision: Enforce strict discipline in use of temporary facilities. To minimize waste and abuse, limit availability of temporary facilities to essential and intended uses.
- b. Maintenance: Maintain facilities in good operating condition until removal.
 - i. Maintain operation of temporary enclosures, heating, cooling, humidity control, ventilation, and similar facilities on a 24-hour basis where required to achieve indicated results and to avoid possibility of damage.
- c. Temporary Facility Changeover: Do not change over from using temporary security and protection facilities to permanent facilities until Substantial Completion.
- d. Termination and Removal: Remove each temporary facility when need for its service has ended, when it has been replaced by authorized use of a permanent facility, or no later than Substantial Completion. Complete or, if necessary, restore permanent construction that may have been delayed because of interference with temporary facility. Repair damaged Work, clean exposed surfaces, and replace construction that cannot be satisfactorily repaired.
 - i. Materials and facilities that constitute temporary facilities are property of Contractor.
 - ii. At Substantial Completion, repair, renovate, and clean permanent facilities used during construction period.

Z. Dust Control: Contractor shall take reasonable measures to prevent unnecessary dust. Earth surfaces subject to dusting shall be kept moist with water or by application of a chemical suppressant. When practicable, dusty materials in piles or in transit shall be covered to prevent blowing.

AA. Pollution Control: Contractor shall prevent the pollution of watercourses by sanitary wastes, sediment, debris, and other substances resulting from the construction activities. No sanitary wastes will be permitted to enter any watercourse other than sanitary sewers. No sediment, debris, or other substance will be permitted to enter sanitary sewers, and reasonable measures will be taken to prevent such materials from entering any watercourse.

BB.GUIDELINES FOR OPEN EXCAVATIONS

- a. Required excavations shall be restored to the level of the adjacent surfaces as soon as practicable. Unsupervised open excavations on public properties are not permitted. Every person who for any purpose makes or causes to be made any excavation in, upon, under, through or adjoining any street, sidewalk, alley, park, boulevard, parkway or any other public properties, and shall leave any part or portion thereof open shall provide effective protection to the public.
- b. All excavations in roadways shall be protected and secured in compliance with existing federal, state and local codes and standards, including, but not limited to the most current edition of the Manual of Uniform Traffic Control Devices.
- c. All unsupervised excavations not within roadways shall be protected and secured. A protective cover over an excavation shall be installed so that it can sustain the weight of any persons and/or objects placed upon it. The cover shall be fixed to the ground so it cannot be moved. Protective covers shall have no opening(s) or protuberance(s) of sufficient size to cause a fall and/or injury. Protective coverings shall meet OSHA requirements. Advance warning devices shall be installed as necessary.
- d. Any excavation that is not covered shall be fenced in such a way that it surrounds that entire area under excavation so as to prevent entry by any persons day or night. **The protective fencing shall be a minimum of 48" in height and Orange color.** The protective fence shall be constructed in such a manner that it is adequately secured and will remain upright at all times under normal site conditions. Protective fencing shall meet OSHA requirements.
- e. All protective coverings and/or fences on excavations shall be inspected at least daily to assure integrity. Protective coverings and/or fences in heavily trafficked areas shall be inspected more often as necessary.
- f. The site shall be kept in a safe condition whenever the contractor is not active on the site. Public access to the site shall be restricted by the placement of "Temporary Plastic Safety Fence (Orange Plastic Mesh, 48-inches High)". Installation shall be according to manufactures specifications and locations shown on the plans. The Contractor shall place the 48" high orange plastic mesh fencing around the construction project areas that are open or will be exposed during the day and/or for the entire night.

CC. Trash Dumpster: It shall be the responsibility of the contractor to maintain accessibility to the trash and recycle bins for the building personnel as well as the trash company. the County will have portions of the Parking Lot of the Health Department building for the contractor to place their dumpsters. The Contractor shall coordinate with the County when they plan to have the dumpsters emptied or removed. The location will be discussed at the Pre-construction meeting to the contract award contractor.

DD. No separate payment will be made for furnishing, the installation of all materials and appurtenant work, maintenance, and removal of any Temporary Facility needed for the completion of the Work. All costs pertaining to these items of the Temporary Facilities shall be included in the other contract prices.

TS-11 DEBRIS CONTROL

- A. During construction, care shall be taken to ensure public safety in the project area. The Contractor shall maintain the project area so that it is free of debris at all times. As each

major component of work is completed, excess materials and unnecessary equipment shall be removed from the project area and corresponding backfilling and clean up shall be done promptly.

- B. No separate payment will be made for the debris control. All costs pertaining to this item shall be included in the contract prices of other items.

TS-12 MOBILIZATION

- A. Description: This item shall consist of the preparatory work and operations, including, but not limited to, those necessary for the movement of personnel, equipment, supplies and incidentals to the project site, for the establishment of construction offices and other facilities necessary for work on the project, including contract bonds and insurance, and for all other work and operations that must be performed or costs incurred prior to beginning work on the various items on the project site.
- B. Mobilization shall conform to Section 618 of the MoDOT Standard Specifications.
- C. Basis of Payment: Payment for mobilization will be made incrementally. Payment item for Mobilization will be Lump Sum of the ALL the Unit Bids.
 - a. Partial Payments. Each partial payment will be 25 percent (25%) of the contract price for mobilization. For purposes of this calculation, the original contract price will be construed as the total dollar value of all contract line items. The partial payments for mobilization will be paid incrementally as follows:
 - 1. The first partial payment will be made when five percent (5%) of the original contract amount is earned.
 - 2. The second partial payment will be made when ten (10%) percent of the original contract amount is earned.
 - 3. The third partial payment will be made when 25 percent (25%) of the original contract amount is earned.
 - 4. The fourth partial payment will be made when 50 percent (50%) of the original contract amount is earned.

TS-13 EXISTING HAZARDOUS MATERIAL INFORMATION

- A. This Document with its referenced attachments is part of the Procurement and Contracting Requirements for Project. They provide Owner's information for Bidders' convenience and are intended to supplement rather than serve in lieu of Bidders' own investigations. They are made available for Bidders' convenience and information, but are not a warranty of existing conditions. This Document and its attachments are not part of the Contract Documents.
- B. An existing asbestos report for Project, prepared by XXXXX, is available for viewing on Jackson County Public Works Department Web site and at the office of Owner
- C. An existing lead report for Project, prepared by prepared by XXXXX, is available for viewing

on Jackson County Public Works Department Web site and at the office of Owner.

- D. An existing mold report for Project, prepared by prepared by XXXXX, is available for viewing on Jackson County Public Works Department Web site and at the office of Owner.
- E. Geotechnical Data for reports and soil-boring data from geotechnical investigations are available for viewing on Jackson County Public Works Department Web site and at the office of Owner.

TS-14 PHOTOGRAPHIC DOCUMENTATION

A. INFORMATIONAL SUBMITTALS

- a. Key Plan: Submit key plan of Project site and building with notation of vantage points marked for location and direction of each photograph. Indicate elevation or story of construction. Include same information as corresponding photographic documentation.
- b. Digital Photographs: Submit unaltered, original, full-size image files within three days of taking the photographs.
 - i. Digital Camera: Minimum sensor resolution of 8 megapixels.
 - ii. Identification: Provide the following information with each image description in file metadata tag: a. Name of Project. b. Date photograph was taken. c. Description of vantage point, indicating location, direction (by compass point), and elevation or story of construction.

B. PHOTOGRAPHIC MEDIA

- a. Digital Images: Provide images in JPG format, with minimum size of 8 megapixels.

C. CONSTRUCTION PHOTOGRAPHS

- a. General: Take photographs using the maximum range of depth of field, and that are in focus, to clearly show the Work. Photographs with blurry or out-of-focus areas will not be accepted.
 - i. Maintain key plan with each set of construction photographs that identifies each photographic location.
- b. Digital Images: Submit digital images exactly as originally recorded in the digital camera, without alteration, manipulation, editing, or modifications using image-editing software.
 - i. Date and Time: Include date and time in file name for each image.
 - ii. Field Office Images: Maintain one set of images accessible in the field office at Project site, available at all times for reference. Identify images in the same manner as those submitted to Architect.
- c. Preconstruction Photographs: Before commencement, take photographs of Project site, including existing items to remain during construction, from different vantage points, as directed by Architect. Submit photos at the first progress meeting.
 - i. Take at least 50 color photographs that show the existing site conditions before starting Work.
 - ii. Take at least 200 color photographs of the existing building to accurately

record physical conditions at start of construction.

- d. Periodic Interior Restoration, Rehabilitation and Renovation Photographs: Take 80 color photographs weekly, with timing each month adjusted to coincide with the cutoff date associated with each Application for Payment. Select vantage points to show status of construction and progress since last photographs were taken. Submit photos previously taken at each progress meeting.
- e. Final Completion Interior Restoration, Rehabilitation and Renovation Photographs: Take 200 interior color photographs after date of Substantial Completion for submission as Project Record Documents and 50 exterior photographs. Architect will inform contractor of desired vantage points.
- f. Additional Photographs: Architect may request photographs in addition to periodic photographs specified.
 - i. Three days' notice will be given, where feasible.
 - ii. In emergency situations, take additional photographs within 24 hours of request.
 - iii. Circumstances that could require additional photographs include, but are not limited to, the following: a. Immediate follow-up when on-site events result in construction damage or losses. b. Substantial Completion of a major phase or component of the Work.

TS-15 ASBESTOS REMOVAL

- A. The contractor work specified within the contract shall be the removal of asbestos-containing material or Hazardous Material encountered by contract with persons knowledgeable, qualified, and certified in the removal, treatment, handling, and disposal of asbestos-containing material, and the subsequent demolition, construction, repairing, cleaning of the affected environment.
- B. All work shall be in accordance with all applicable federal, state, and local regulations.
- C. **DEFINITIONS:**
 - a. Asbestos - Any material that contains more than one percent (1%) Asbestos and is friable or is releasing Asbestos fibers into the air above current action levels established by the United States Occupational Safety and Health Administration.
 - b. Construction Waste: Building, structure, and site improvement materials and other solid waste resulting from construction, remodeling, renovation, or repair operations. Construction waste includes packaging.
 - c. Disposal: Removal of demolition or construction waste and subsequent salvage, sale, recycling, or deposit in landfill, incinerator acceptable to authorities having jurisdiction, or designated spoil areas on Owner's property.
 - d. Existing to Remain: Protect items indicated to remain against damage during demolition.
 - e. Hazardous Environmental Condition- The presence at the Site of Asbestos, Lead-Based Paint, PCBs, Petroleum, Hazardous Waste, or Radioactive Material in such quantities or circumstances that may present a substantial danger to persons or property exposed thereto in connection with the Work.
 - f. Hazardous Waste- The term Hazardous Waste shall have the meaning provided in Section 1004 of the Solid Waste Disposal Act (42 USC Section 6903) as

amended from time to time.

- g. Laws or Regulations- Any and all applicable laws, rules, regulations, ordinances, codes and orders of any and all governmental bodies, agencies, authorities and courts having jurisdiction.
 - h. Lead-Based Paint- Any paint, varnish, stain, or other applied coating that has one (1) mg or more of lead per square centimeter. The terms "leaded paint" and "lead-containing paint" are synonymous with Lead-Based Paint.
 - i. Petroleum- Petroleum, including crude oil or any fraction thereof which is liquid at standard conditions of temperature and pressure (60 degrees Fahrenheit and 14.7 pounds per square inch absolute), such as oil, petroleum, fuel oil, oil sludge, oil refuse, gasoline, kerosene, and oil mixed with other non-Hazardous Wastes and crude oils.
 - j. Remove: Remove and legally dispose of items except those indicated to be reinstalled, salvaged, or to remain the property of Jackson County, Mo..
- D. If the contractor encounters suspect Asbestos-Containing Materials (ACM) not previously identified in the contract, the contractor shall immediately notify the Owner in accordance with the contract requirements. The Contractor will have the suspect material sampled and tested, and the contractor shall not remove the additional suspect ACM until directed by the Testing company that is hired by the contractor.
- a. The asbestos removal designee shall supply all labor, materials, equipment, services, insurance (if designee is contract personnel), and incidentals which are necessary or required to perform the work in accordance with applicable governmental regulations and these specifications.
 - b. The contractor shall monitor and test for airborne asbestos particles during working hours within the area of the property or fence line. The contractor shall conduct operations to keep airborne particles beyond this area within the established regulation limits. The contractor shall furnish the Owner copies of correspondence, test results, recommendations and other information to document contractor's compliance with the following requirements:
 - c. When asbestos removal is completed, all work shall be inspected by the contractor for the presence of asbestos debris. Removal and cleaning shall continue until air monitoring clearance testing indicates the level of airborne fibers meets required levels. The engineer shall be notified when sampling is started. The contractor shall provide documentation to the Owner within 24 hours after the sampling has been completed that the level of airborne fibers meets required levels.
 - d. For asbestos abatement projects requiring third party air monitoring as determined by the Owner based on Contractor findings within the job, the contractor shall cooperate and coordinate with the Owner and the third party air sampler designated by the Contractor and approved by the Owner to perform the third party air sampling. The contractor shall provide to the engineer a minimum of 48 hours notice of the time when the services of the third party air sampler will be required as a result of the contractor's work. The contractor shall arrange work so as not to interfere with the third party air sampler's ability to conduct the necessary air sampling. The contractor and the third party air sampler shall work

cooperatively with the engineer in a sequence such that air sampling shall be conducted in a proper and timely manner by the third party air sampler with minimal interruption to any other party.

- e. Contractor shall protect the existing surfaces from damage.
 - f. If the Contractor encounters Asbestos of items that he or she is planning to salvage, then No salvage of items containing asbestos material will be permitted.
 - g. Post caution signs in and around the work area to comply with OSHA Regulation 29 CFR 1910.1001(g)(1).
 - h. Prior to commencement of work, the workers shall be instructed, and shall be knowledgeable, in emergency evacuation and evacuation procedures to be followed in the event of compressor failure shall be included in worker training prior to commencement of work.
 - i. All respiratory protection shall be provided to workers in conjunction with a respiratory protection program which shall meet the requirements of 29 CFR 1910.134(b)(1-11). This program shall be posted at the work site.
 - j. Provide workers with personally issued and marked respiratory equipment approved by The National Institute for Occupational Safety and Health (NIOSH).
- E. Contractor shall perform the asbestos removal and work after hours starting at 6:00 p.m. and ending at 10:00 p.m. during the Weekdays unless weekend work is approved by the Owner.
- F. Manufacturer's certification that vacuums, negative air pressure equipment, and other local exhaust ventilation equipment conform to ANSI 29.2-79.
- G. Respiratory protection shall be worn by all persons potentially exposed to asbestos or Hazardous Materials from the initiation of the asbestos demolition project until all areas have been given clearance. Clearance shall be obtained by visual inspection and air monitoring.
- H. All removal shall be performed inside of a "gross" removal containment.
- I. The Contractor shall provide adequate electrical for the asbestos removal such as at least two 20 amp circuits. All the bathrooms have an interior existing outlet(s). Regardless, the Contractor shall provide Temporarily Lighting and/or Electrical connections.
- J. Contractor shall provide clearance air monitoring.
- K. DISPOSAL:
- a. All RACM and Category I nonfriable ACM shall be disposed of within seven days of removal from the building or structure. All RACM and ACM shall be disposed in accordance with applicable EPA, OSHA, MDNR and local agencies' regulations.
 - b. The contractor shall identify or mark hauling vehicles used to transport asbestos waste during loading, transporting and unloading in accordance with applicable regulations for transporting asbestos waste. The waste shall be transported in enclosed roll-offs or dumpsters, vehicles that have completely enclosed cargo areas, or a four-sided cargo area that shall be completely covered with two layers of 6-mil thick plastic sheeting or equivalent covering while the waste is being

transported.

- c. The contractor shall provide a Waste Shipment Record to the waste site owner or operator at the time the waste is delivered to the waste disposal site. A copy of the Waste Shipment Record shall be provided to the engineer.
- L. The Contractor shall provide to the Owner a permit from the Missouri Department of Natural Resources (MDNR) prior to starting any and all asbestos removal. No waiver will be granted.
- M. Perform Disposal preparation work in accord with MDNR Air Quality Ordinance Disposal bags shall be properly labeled in accordance with EPA, DOT and OSHA. Additionally, label bags or containers containing asbestos debris as follows:

Jackson County, MO Health Department
3651 NE Ralph Powell Road
Lee's Summit, MO 64064
- N. Whenever trucks or dumpsters are being loaded or unloaded with asbestos waste, post in accord with the NESHAP Standard - DANGER, ASBESTOS DUST HAZARD, CANCER AND LUNG DISEASE HAZARD, AUTHORIZED PERSONNEL ONLY.
- O. Waste shall be transported in enclosed roll-offs or dumpsters or vehicles that have completely enclosed cargo areas.
- P. Debris containing asbestos or lead-based paint chips should be handled and disposed of in accordance with all applicable local, State, and Federal requirements.
- Q. Transport waste to a MDNR approved landfill. Complete a waste shipment record for each load of waste in accord with the NESHAP Standard. Return the record, signed by waste disposal site owner/operator to Jackson County Public Works Inspector **within 10 working days upon receipt of completely executed waste shipment record.**
- R. Submittals **After Asbestos Removal Completion**
- S. Upon **completion** of the project, the contractor will submit a report to the Owner's representative that describes the work that was performed. All submittals will be provided within 30 days. The report will include the following:
 - a. Work Site Daily Logs, indicating at a minimum
 - b. Work performed
 - c. Amount of material removed
 - d. Names of workers present on job site
 - e. Times that those workers were present
 - f. Documentation of Disposal
 - g. Copies of any change orders, etc. and any supporting documentation

T. CLEANING After Asbestos Removal

- a. Cleaning all remaining surfaces within the work area shall be thoroughly cleaned to remove loose dust. The cleaning shall be performed using damp cloths wetted with a cleaning solution, as described in this work plan, and vacuum cleaners equipped with HEPA filters. The negative air machines will be in continuous operation throughout the cleaning phase. Caution: Cleaning may introduce water into the containment area. The remediation contractor is responsible for following the appropriate lock out/tag out procedures for any electrical components in the work area. The remediation contractor is also responsible for protecting all live electrical circuits running into and through the work area.
- b. Cleaning Solution for surfaces that have been damaged by water and/or mold, as well as, areas where there is a possibility of mold regrowth (e.g., wall cavities and studs) shall be thoroughly cleaned with an appropriate cleaning solution. Any chemicals to be used must be designated as EPA Approved. Because the solution may be a reactive chemical, damage to porous materials might occur. The remediation contractor shall use due care when applying this solution. Adequate ventilation and proper worker PPE, in accordance with the product's specifications and guidelines, must be maintained, during use of any cleaning solutions. The cleaning solution must meet the following requirements:
 1. It must have an EPA approval number
 2. It must be used for the approved purpose
 3. It must be used according to the label instructions.

U. Worker Protection Personal Air Monitoring shall be enforced throughout the project. Personal air sampling is conducted during renovation or abatement projects to determine an employee's exposure (outside any respirator) to airborne fibers. Representative, daily personal monitoring during abatement projects is required by the OSHA Asbestos Standard at Title 29 Code of Federal Regulations (29 CFR) 1926.1101.

- V. Contractor shall provide two days notice prior to scheduling this work.
- a. Third Party Air Monitoring or in monitoring abatement activities shall be enforced during the duration of the Abatement Removal. The Owner's representative and/or testing company shall assist on the monitoring process.

W. The Contractor shall hire the Abatement company to test, evaluate, remove the ACM and provide documentation to the Owner. The Abatement testing company shall be approved by the Owner and shall follow ALL the Jackson County, MO. Compliance Review office requirements.

X. There is a \$10,000 Allowance for the unit Bid item for the "Allowance for Hazardous Material Abatement". The cost for the ACM testing company and the contractor's certified ACM specialist for removal of the hazardous material will be subsidiary to this Unit Bid. The payment process will follow the Force Account specifications. If this Allowance is not used, then it will be a credit to the Owner for the project.

TS-16 DISPOSAL OF EXCESS MATERIAL

Excess materials shall be legally disposed of at locations outside the right-of-way and provided by the Contractor. No direct payment will be made for this work.

TS-17 FORCE ACCOUNT

- A. Force Account shall conform to Section 105.1.1 Authority of Engineer, Section 109.4.3 Equitable Adjustment, Section 109.4.4 Application of Force Account, and Section 109.5 Force Account Computation of the Missouri Standard Specifications for Highway Construction (2022).
- B. The Contractor shall perform other unforeseen work, for which there is no condition included in the contract, whenever it is deemed necessary or desirable to complete the work as designated by the County. Such work shall be performed in accordance with the Standard Specifications and as directed by the County.
- C. Payment for the work performed under this Technical Specification shall be made in accordance with the bid unit prices where the requested work is covered by an item listed in the bid. If the work is not represented by a unit price listed in the bid, payment will be in accordance with the General Conditions and more specifically GC-35 "Extra Work".

TS-18 ITEMS NOT LISTED IN THE BID

There will be no measurement or separate payment for any items of work not specifically identified and listed in the Bid, and all costs pertaining thereto will be included in the contract unit prices for other items listed in the Bid.

TS-19 SUBSIDIARY WORK

All work shown in the plans or referred to in the Technical Specifications and not specifically set forth in the Itemized Bid as a pay item shall be considered a **SUBSIDIARY** obligation of the Contractor and all costs in connection therewith shall be included in the prices named in the bid.

TS-20 ESTIMATED QUANTITIES

- A. Payment for the following listed items will be based on the contract quantity shown on the plans. No final measurement of quantities will be made.
- B. In the event of authorized changes, during construction, or appreciable error found in an estimated quantity, the Contractor may request in writing that a final measurement for payment be made of that item. Additionally for the above noted reasons the Engineer may make a final measurement for payment. If a measurement and re-computation of the quantity is done it shall be accordance with these Technical Specifications and the Standard Specifications and payment made based on the unit price noted in the bid.

TS-21 PERMITS

The County will provide the General Contractor a permit from the Building Inspector with JCPW Planning and Zoning, at no additional cost.

TS-22 4 IN THICK FULL DEPTH PATCHING FOR PARKING LOT

- A. This work requires 4" deep saw cutting, removal and disposal of the existing pavement, and

the replacement with KCAPWA Type 5-01 asphalt on a compacted subgrade in accordance with the detail drawing. RAC is acceptable.

- B. If it is determined that subgrade compaction is required and if it cannot be obtained by moisture control and compaction of the upper 12 inches, the unsuitable material shall be excavated to a depth not to exceed 12 inches and replaced with satisfactory material compacted in layers not to exceed 6 inches, except as otherwise permitted by the Engineer.
- C. Compaction of the subgrade to the approximate density of the adjacent material prior to placement of base shall be made with a roller or any other method approved by the Engineer. Inspection of the compaction will be made by visual observation by the Engineer and compaction shall be to his satisfaction.
- D. Only one lane of the pavement shall be removed and replaced at a time.
- E. Any overrun or partial or complete underrun of subgrade compaction shall not be the basis of claim.
- F. Measurement for pavement replacement shall be to the nearest 1/10 square feet.
- G. Payment for the pavement replacement includes saw cutting, removal and disposal of the existing surface and base in the unit price for **"4" Thick Asphalt Parking Lot Full Depth Pavement Patching**" for the respective materials used in the pavement replacement.
- H. The removed material shall be disposed of at locations outside the right-of-way provided by the contractor.

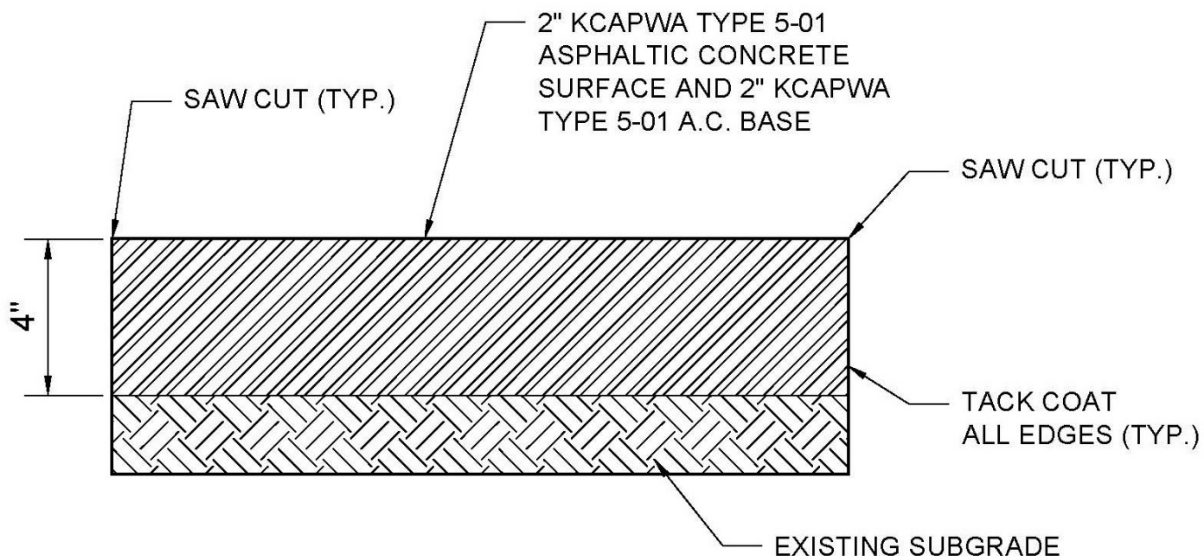

4" FULL DEPTH PAVEMENT
PATCHING DETAIL FOR
PARKING LOT

TS-23 TACK COAT

- A. General: This work shall consist of treating a milled roadway base with bituminous material in accordance with these specifications, as shown on the Plans, or as directed by the County.
- B. Asphalt Material: The type and grade of asphalt material to be used as tack coat shall be SS-1h or approved equal. The rate of application shall be 0.05 to 0.15 gallons per square yard.

Asphalt materials shall be approved by the County prior to use in the work. The County may accept a certified analysis by the material supplier laboratory when a copy of the certified analysis accompanies each shipment of asphalt to the project. The County reserves the right to perform tests of the asphalt material received on the job.

C. Construction:

- 1. Preparation of Existing Surface: The existing surface shall be free of dust, loose material, grease or other foreign material at the time the tack is applied. Preparation of the surface is to be performed by the Contractor before the tack is applied.
- 2. Application of Asphalt Material: Asphalt emulsion shall be applied uniformly with a pressure distributor at the rate specified above. Water may be added to the asphalt emulsion and mixed therewith in such proportion that the resulting mixture will contain no more than 50% of added water, the quantity of added water to be approved by the County. The application of the resulting mixture shall be such that the original emulsion will be spread at the specified rate. The asphalt emulsion shall be heated at the time of application to a temperature in accordance with the manufacturer's recommendation. The tack shall be properly cured and the tacked surface shall be cleaned of dirt and other foreign material before the next course is placed.

The tack coat shall be applied in such manner as to cause the least inconvenience to traffic and to permit one-way traffic without pickup or tracking of the asphalt emulsion.

- D. Measurement: Tack coat for the project will not be measured.
- E. Payment: The placement of tack coat, including the labor, materials, and roadway/parking lot preparation, shall be **SUBSIDIARY** to **"4" Thick Asphalt Parking Lot Full Depth Pavement Patching**".

END OF SECTION