

REAR WALL (EXTERIOR)

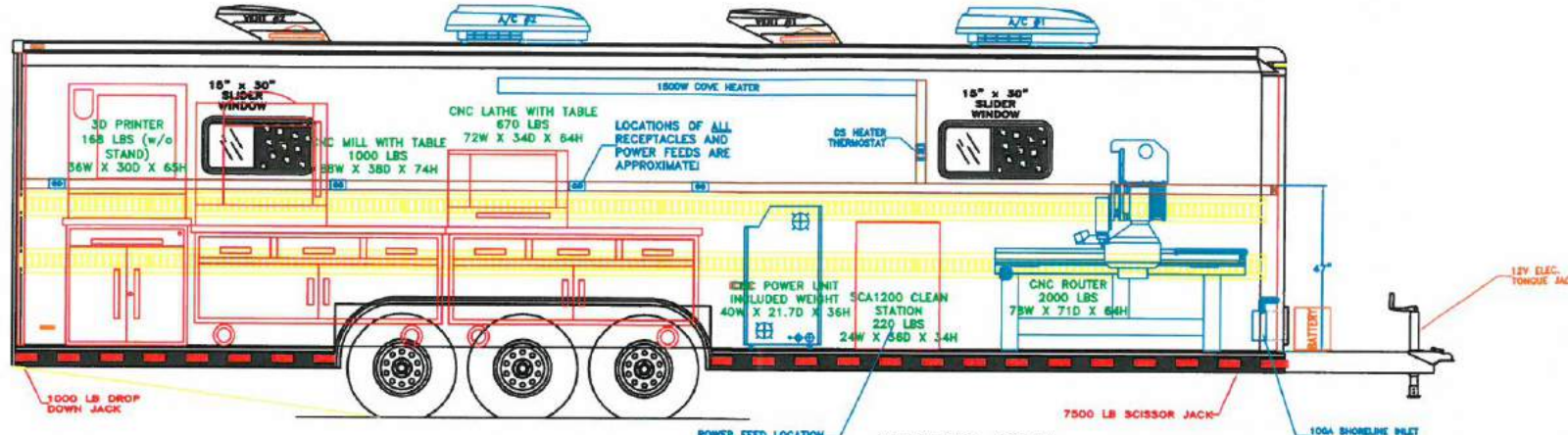

STREET SIDE (INTERIOR)

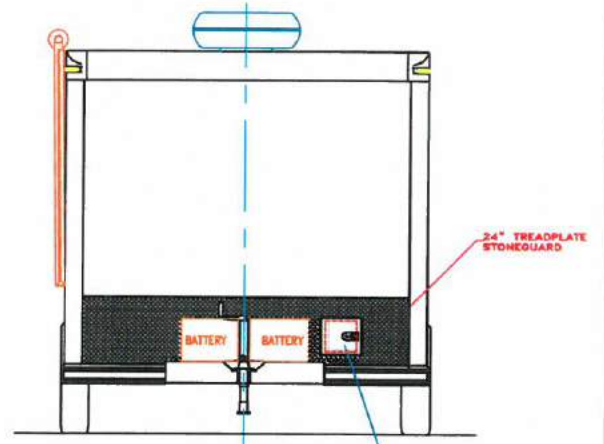

FRONT WALL (EXTERIOR)

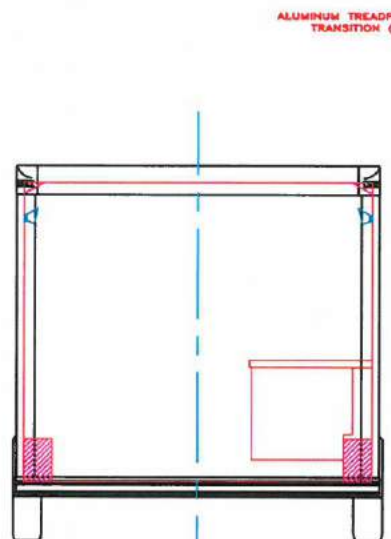

ALUMINUM TREADPLATE TRANSITION (16")

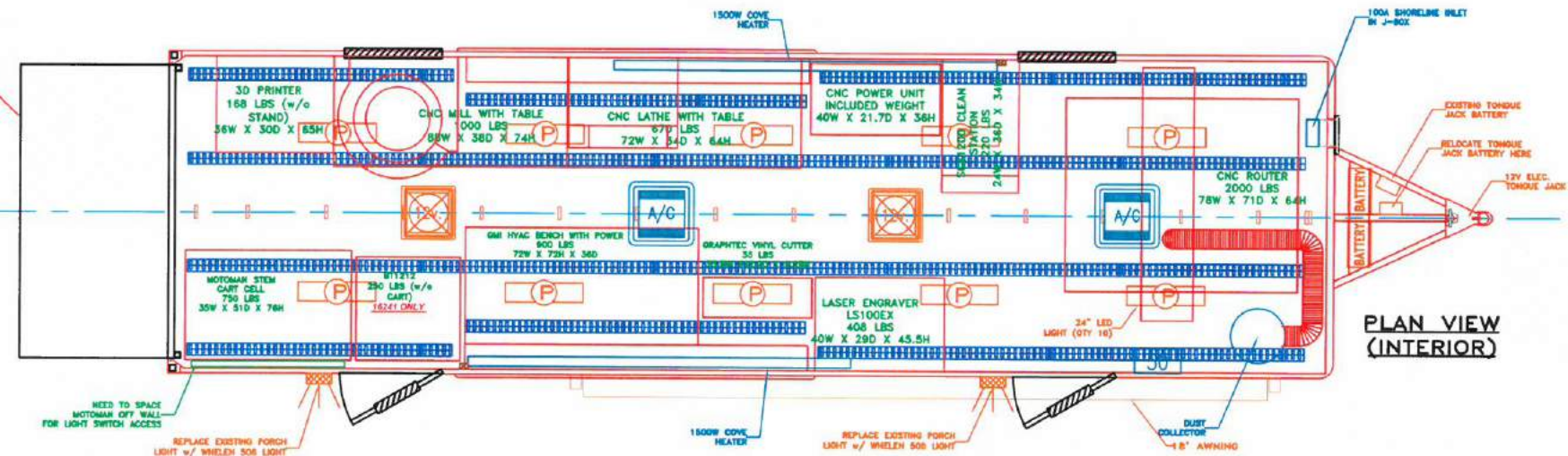

PLAN VIEW (INTERIOR)

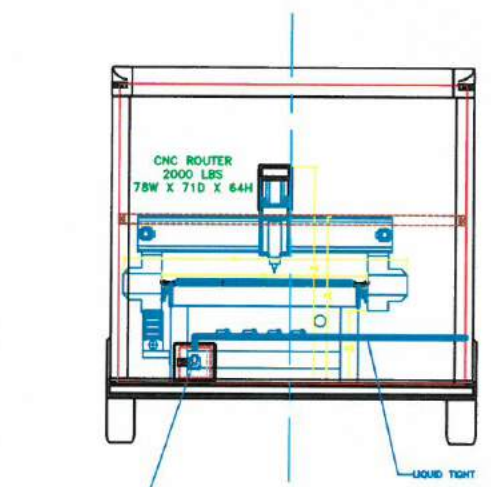

FRONT WALL (INTERIOR)

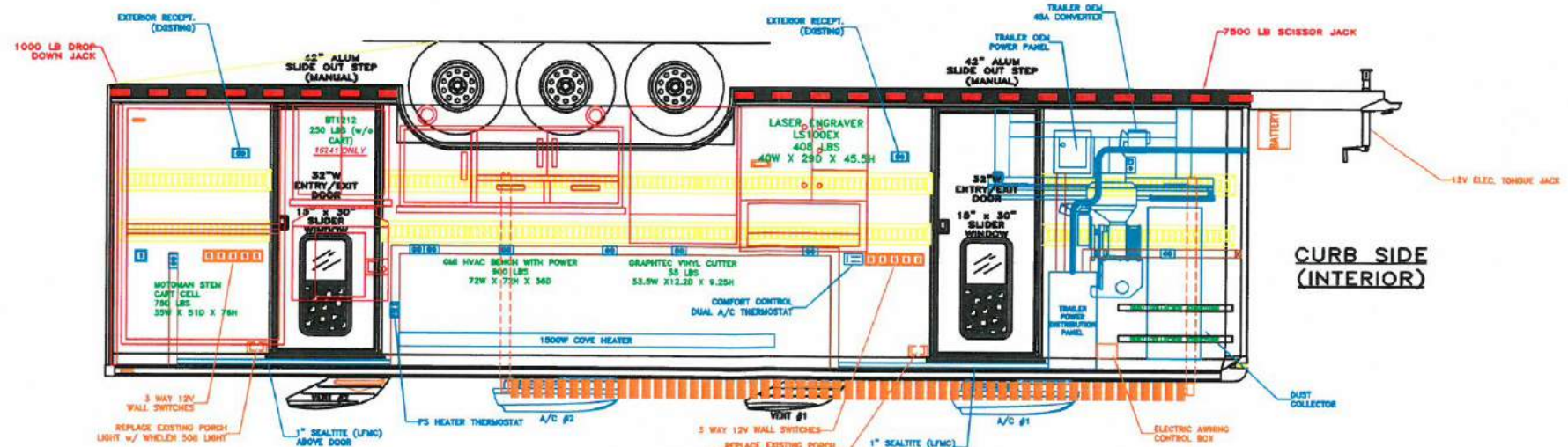

CURB SIDE (INTERIOR)

| | |
|-------------------|------|
| CUSTOMER APPROVAL | DATE |
| | |

FARBER
SPECIALTY VEHICLES
7052 AMERICANA PARKWAY
COLUMBUS, OH 43068
USA

| REV. | DESCRIPTION | DATE |
|------|-------------|------|
| | | |

| | | | |
|---------|-------------|--------------------|--------------|
| ECY | 30' TRAILER | DESIGN ENGINEER | B. HAAG |
| CHASSIS | | LEAD ENGINEER | T. DENNIS |
| | | ENR. MGR. APPROVAL | |
| | | SALES | R. ARMSTRONG |

| | |
|-----------|----------------------|
| CUSTOMER | FSV TRAILER 30 |
| TITLE | PRODUCTION DWG - INT |
| SHEET NO. | D |
| REV. | |
| DATE | |
| REV. NO. | 16241 |
| REV. | P.1 |

**FSV TRAILER 20
MOBILE COMMAND - DUI BAT - COMMUNICATIONS**

Body 20', 24' overall length including tongue, 7,500 GVWR, 102" exterior width, Smooth, seamless and impact resistant FRP fiberglass walls. Bright white gel coat interior and exterior wall finish. 7,000 lb. jack and welded safety chains. Rear ramp door to be spring assisted and 96" wide. Two tinted 30" x 15" windows; day/night shades installed on windows. One grab handle at door location. Deluxe scissor jacks with hand crank. Commercial vinyl flooring. One roof air conditioner, electric heat. 12V and 120V circuit breakers, electronic master disconnect switches for main and auxiliary battery system, 36' shoreline. Custom cabinets cut using CNC router.



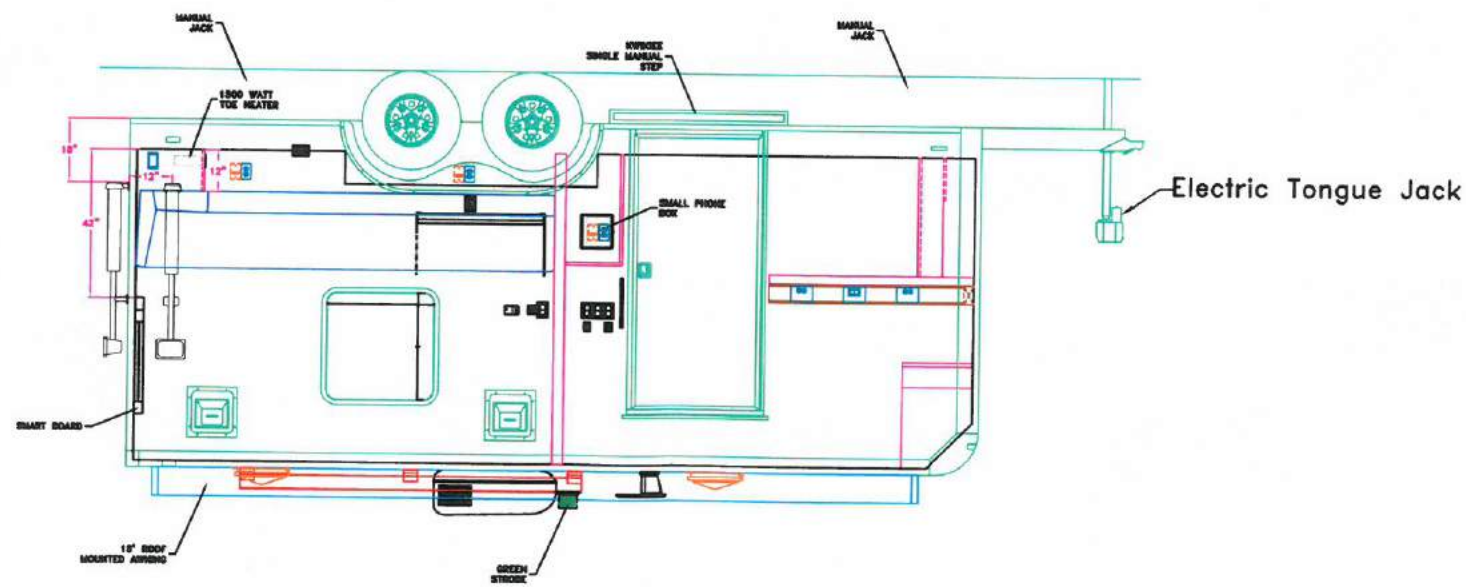
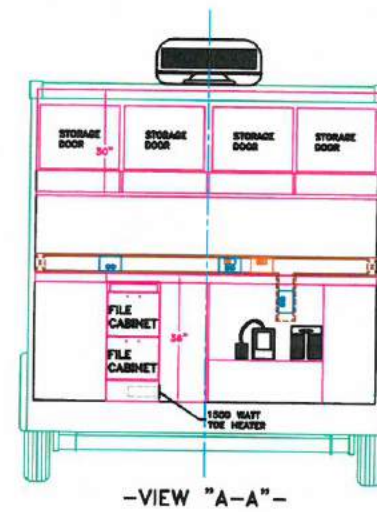
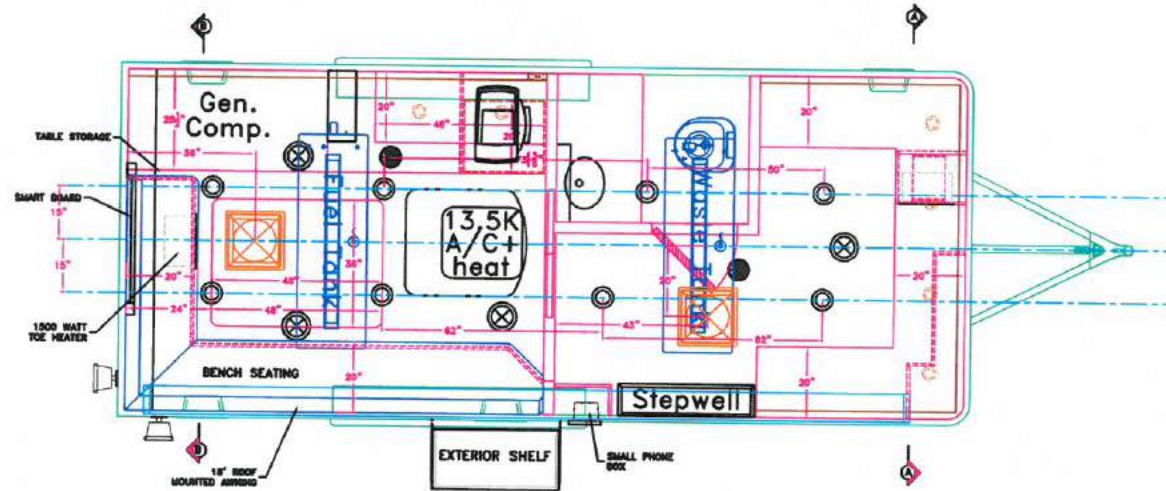
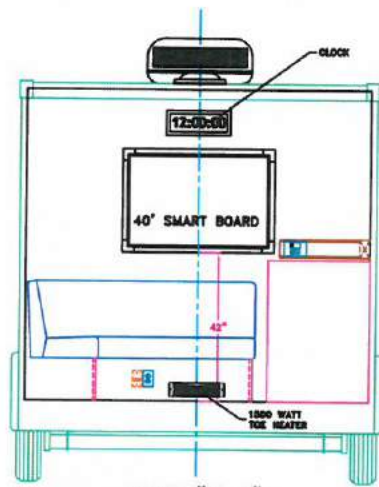
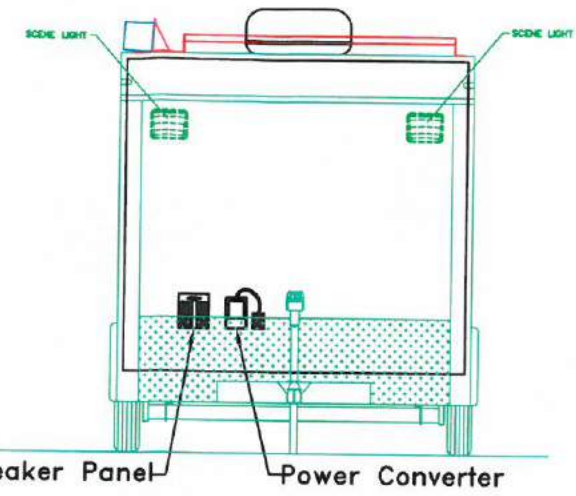
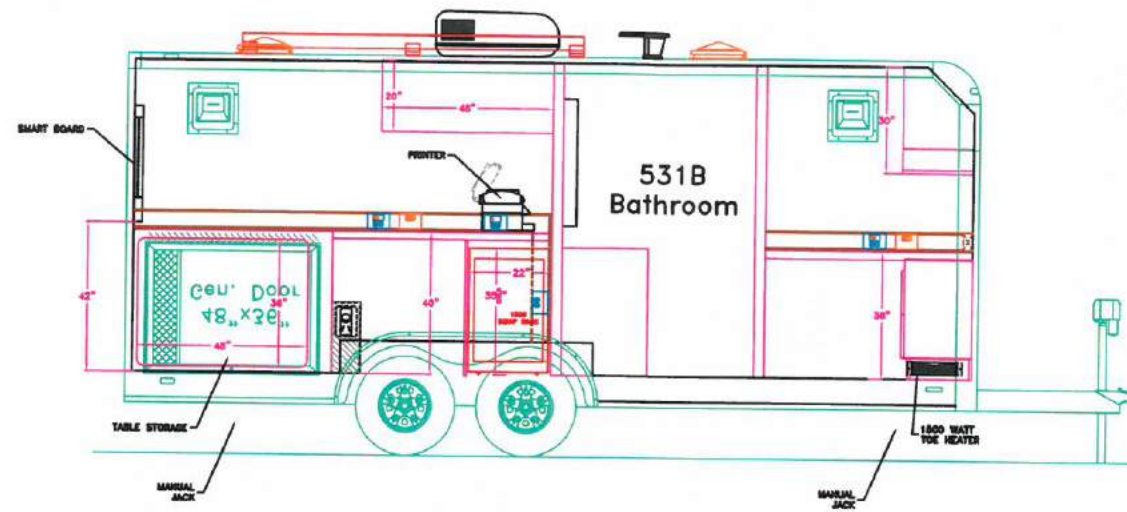
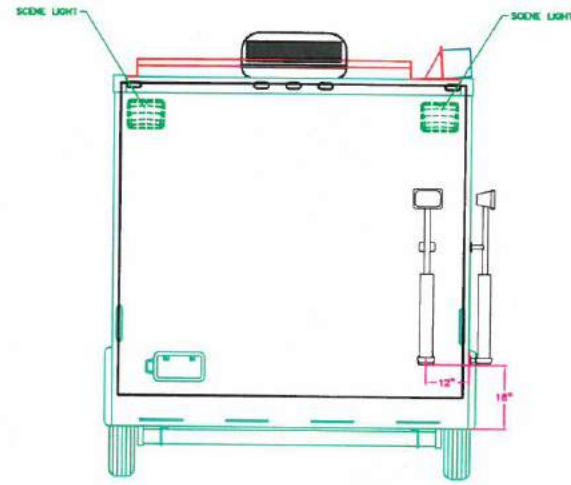

SYMBOL LEGEND:

- Ⓚ 120VAC SWITCH
- Ⓚ 120VAC DUPLEX RECEPTACLE
- Ⓚ 120VAC DUPLEX RECEPTACLE (IN PANDUIT DUCT)
- Ⓚ 120VAC DUPLEX RECEPTACLE WITH RJ-11/RJ-45 JACK(S) (IN PANDUIT DUCT)
- Ⓚ 120VAC EXTERIOR GFCI RECEPTACLE W/WEATHER-PROOF COVER
- Ⓚ 120VAC GFCI RECEPTACLE (IN PANDUIT DUCT)
- Ⓚ 12VDC SWITCH-3 WAY
- Ⓚ RADIO POWER STRIP (RADIOCOMM)
- Ⓚ RJ-45 NETWORK JACK
- Ⓚ RJ-11 PHONE JACK
- Ⓚ 9VDC SMOKE DETECTOR (CEILING MOUNTED)
- Ⓚ 9VDC CARBON MONOXIDE DETECTOR (CEILING MOUNTED)
- Ⓚ DRY ERASE BOARD (SMOOTH WHITE)

NOTE:
(2) #8 FIRE EXTINGUISHERS (SHIP LOOSE)

CUSTOMER APPROVAL

DATE: _____

BY: _____

FARBER
SPECIALTY VEHICLES
7052 AMERICANA PARKWAY
COLUMBUS, OH 43068
USA

REVISION HISTORY

| REV. | DESCRIPTION | ENGINEER | DATE |
|------|-------------|----------|------|
| | | | |

DESIGN ENGINEER: **BCN**

DATE: _____

SCALE: _____

UNIT: _____

CUSTOMER: **FSV TRAILER 20**

TITLE: **PRODUCTION DWG**

SHEET SIZE: **D**

SCALE: **1:24**

UNIT NO.: **16060**

REV: **F.2**

**FSV TRAILER
DOUBLE EXPANDABLE TRAILER -
EOC - COMMAND - COMMUNICATIONS 53'**

53' Quad slide trailer, 65,000 GVWR, dual 40' slides in the main body, dual 8' slides in raised platform. 50Kw generator installed on customer supplied tractor. Dual five-ton HVAC units mounted on front of trailer. Direct TV, TracStar flyaway, VOIP phone kit, (10) Ten 25" monitors, Cat 6 network, Extron video switch, LED lighting package. (34) workstations, private conference room, galley with under counter refrigerator, coffee maker and microwave. Custom aluminum entrance doors with platform steps and handrails, hydraulic lift on the rear. Over 1100 sq ft of fully functional space. Set up time approximately 45 minutes.



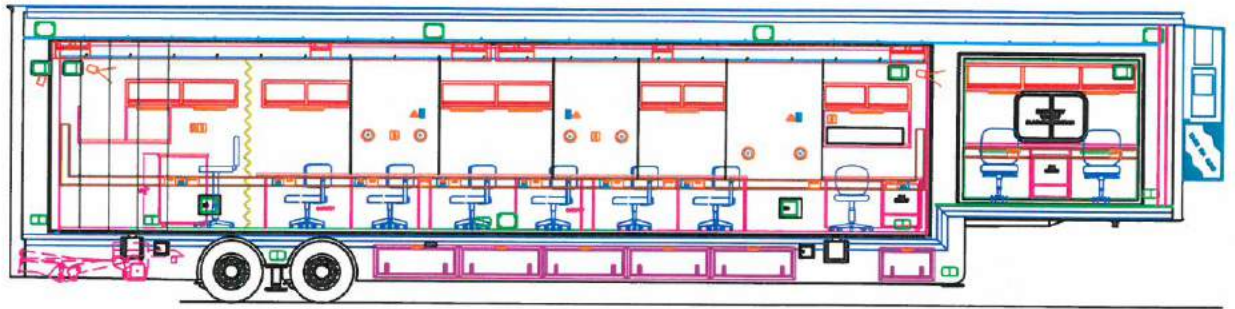

DRIVER SIDE INTERIOR VIEW

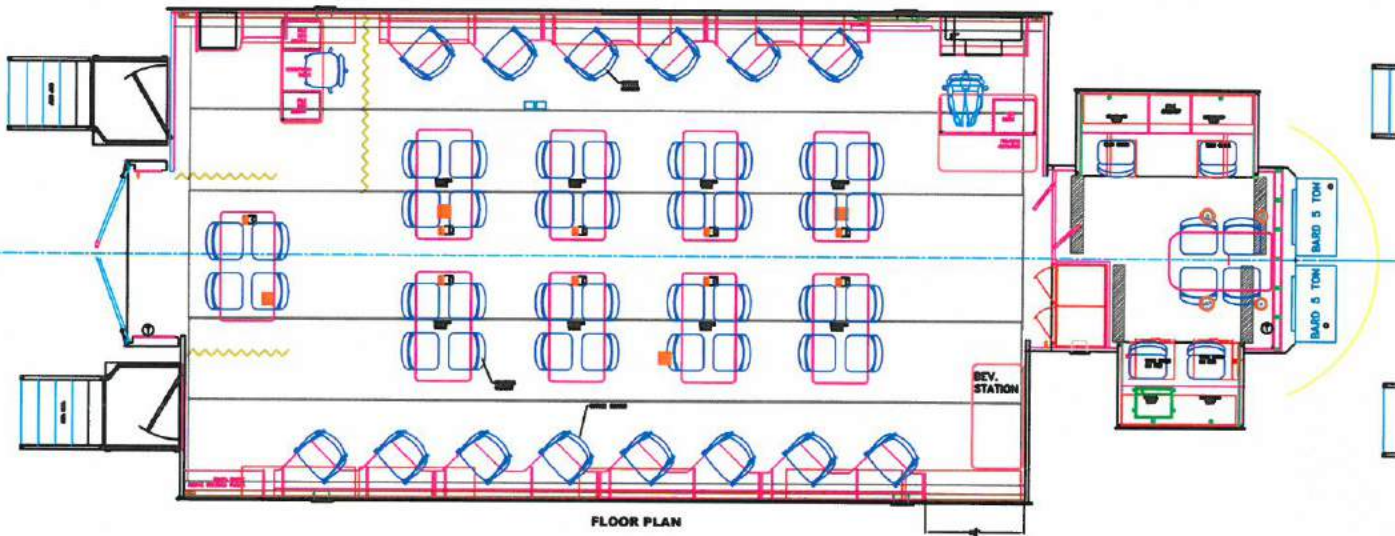

FLOOR PLAN

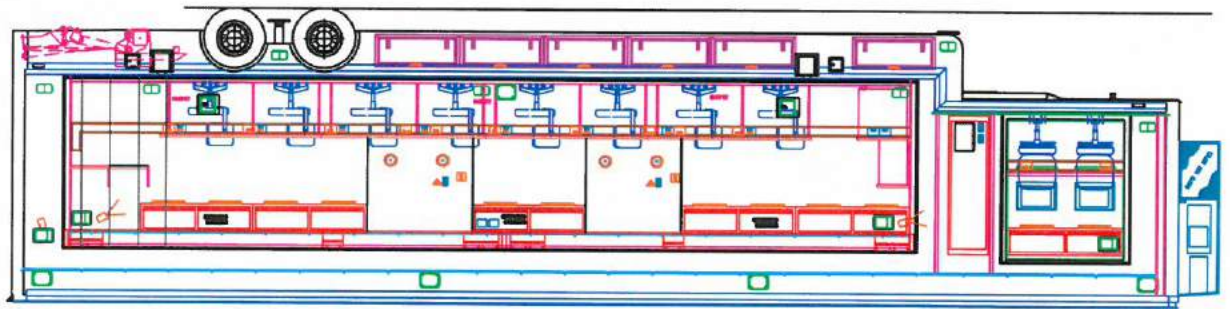

PASSENGER SIDE INTERIOR VIEW

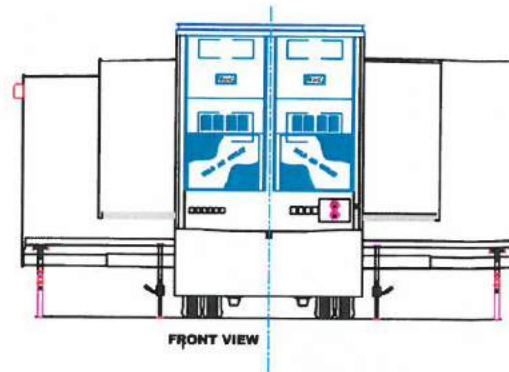

FRONT VIEW

**FSV TRAILER
TWO STORY TRAILER -
EOC - COMMAND - COMMUNICATIONS 53'**

53' two story, quad slide trailer, aluminum frame construction, 6 wheel disc brakes with anti-lock braking system, tridem wheel configuration. Slides feature dual air system and low friction precision bearing rails. Raised roof powered by electric actuators. Rear and side entry doors. Windows feature double pane "Low-E" glass with tinted finish. Full stand up upper floor with access to optional roof deck. Dual zone climate control system with 10 tons cooling high velocity air conditioning. 20Kw heat capacity. Custom designed workstations, private conference room, Full interior LED lighting package. 942 sq. ft. of floor area including main and second floor. 250 sq. ft. of deck area with sturdy powder coated aluminum rails (optional). Total set up time is approximately 20 minutes.



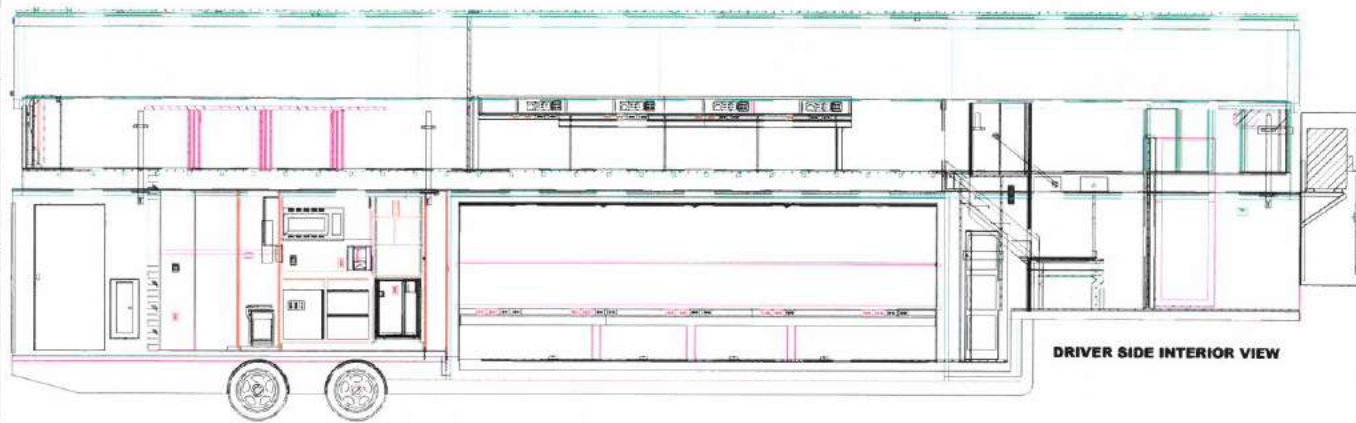

DRIVER SIDE INTERIOR VIEW

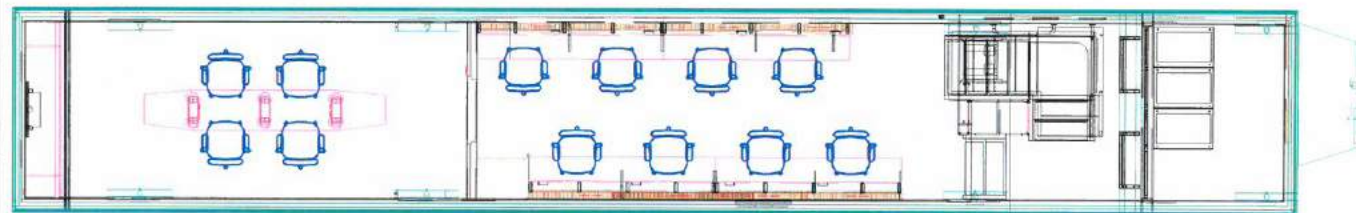

FLOOR PLAN (UPPER)

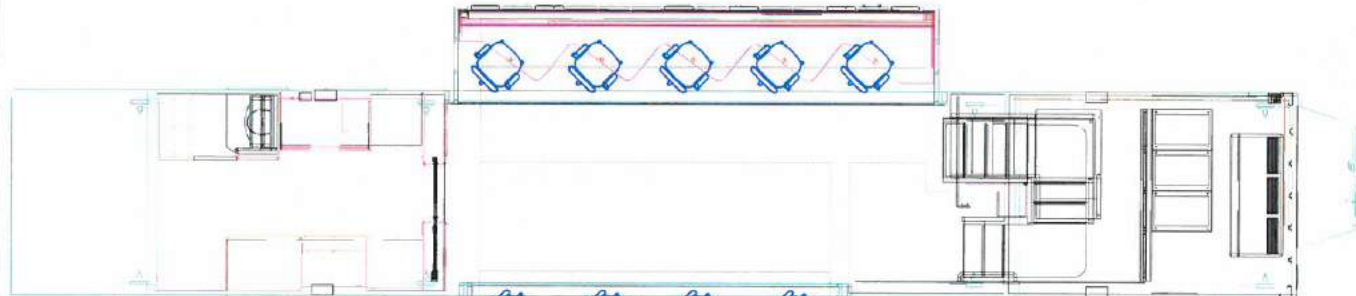

FLOOR PLAN (LOWER)

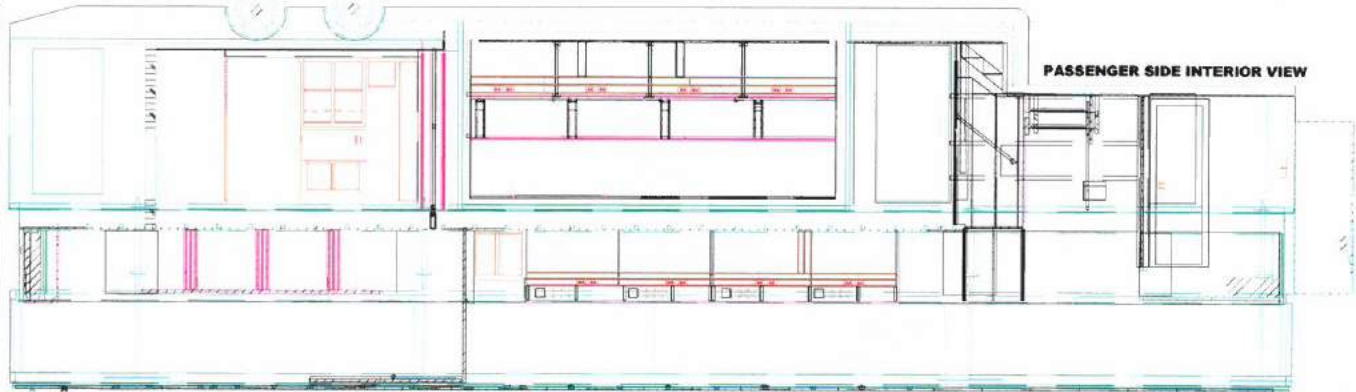

PASSENGER SIDE INTERIOR VIEW

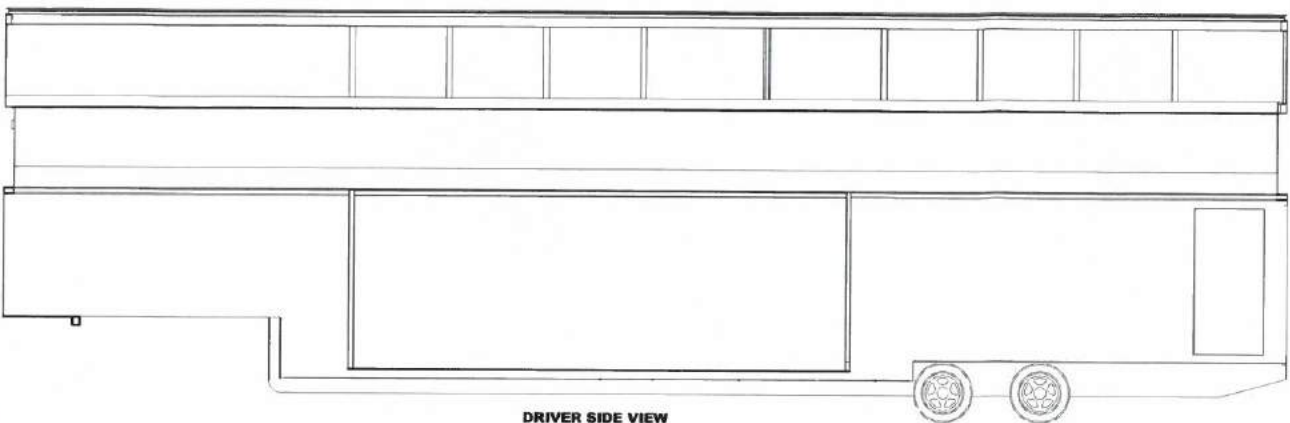

DRIVER SIDE VIEW

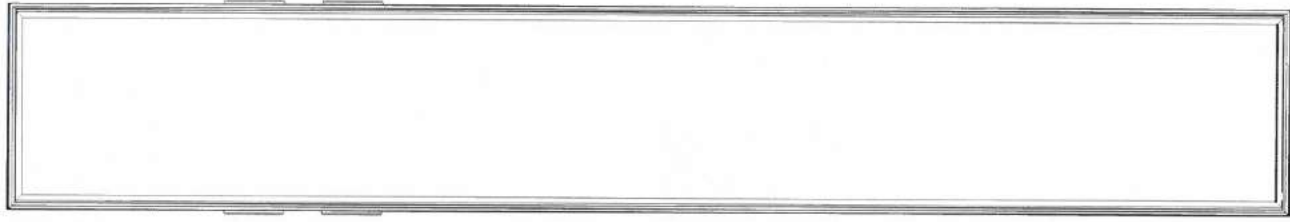

ROOF VIEW

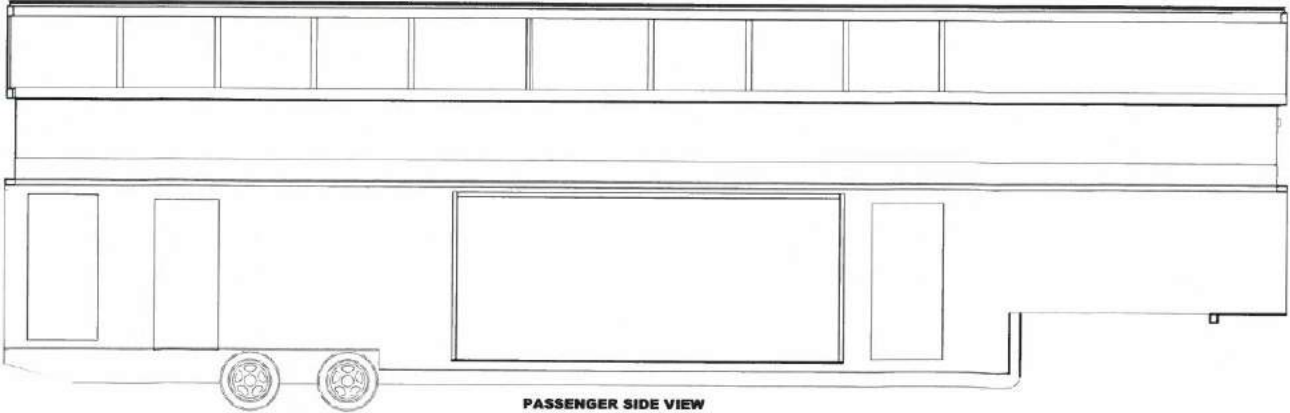

PASSENGER SIDE VIEW

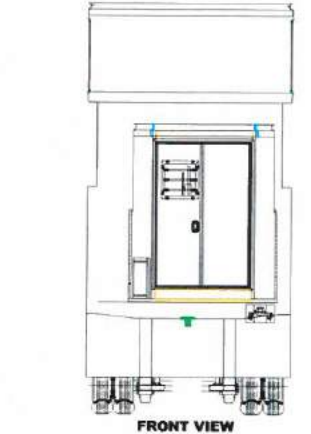

FRONT VIEW

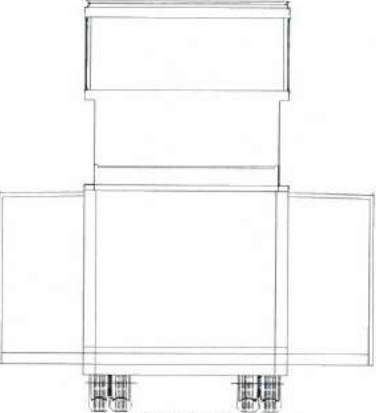

REAR VIEW

CUSTOMER APPROVAL
 PRINT NAME
 SIGNATURE
 DATE

FARBER
 SPECIALTY VEHICLES
 TRAILER
 UPPER LEVEL

| | | | | |
|----------------------------|---------------------------|------------------------------------|-------------------|----------|
| UNLESS OTHERWISE SPECIFIED | PROPERTY AND CONFIDENTIAL | PROJECT: PSV TRAILER 53' TWO STORY | DATE: 3-24-15 | REV: A.5 |
| | | DESIGNER: J. GOOTYER | DRAWING NO: 15323 | |
| | | BY: J. GOOTYER | | |

**FSV CUSTOM FIRE CHASSIS
MULTI-USE EXTRA HEAVY DUTY -
HAZMAT - COMMAND - COMMUNICATIONS 35'**

35' overall length, Cummins ISL 450 hp engine, 42,000 GVWR, Walk in custom aluminum body with slide-out room option. Spartan Extended chassis with three or four entrance doors. LED interior and exterior lighting package. Body includes roll up doors, adjustable shelves, roll out trays, rear roof ladder. Compartment storage areas included with interior and exterior access. Alternative length options available.



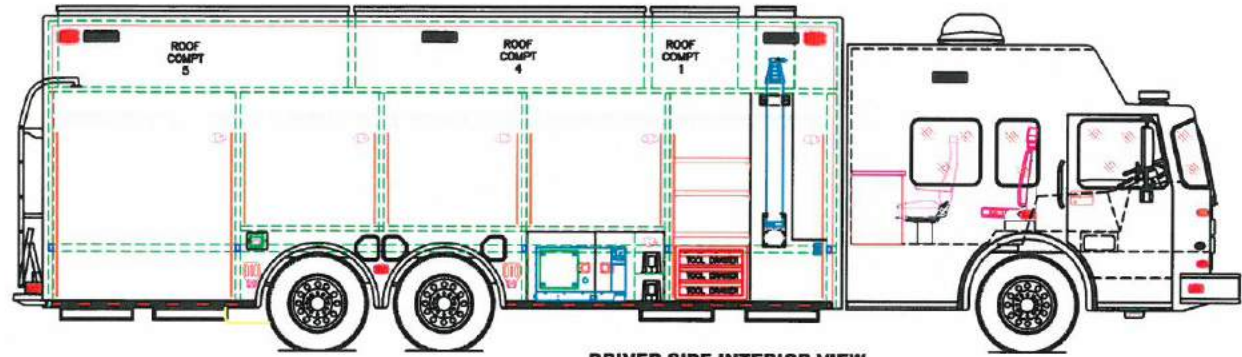

DRIVER SIDE INTERIOR VIEW



DRIVER SIDE VIEW

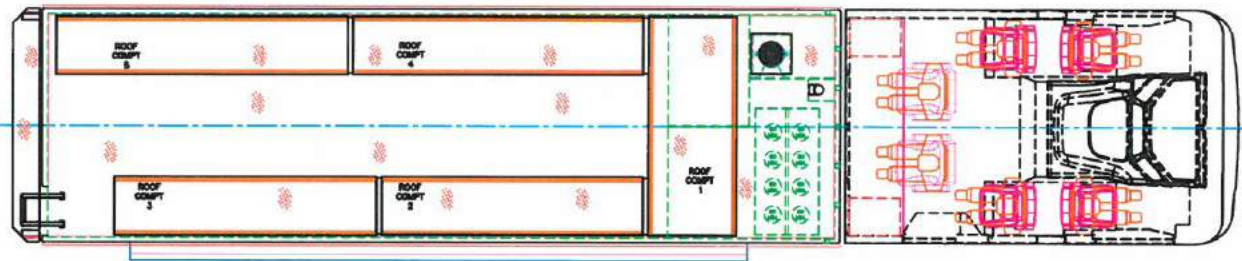
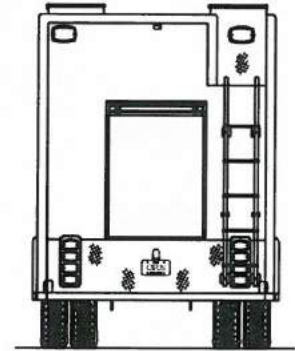

FLOOR PLAN

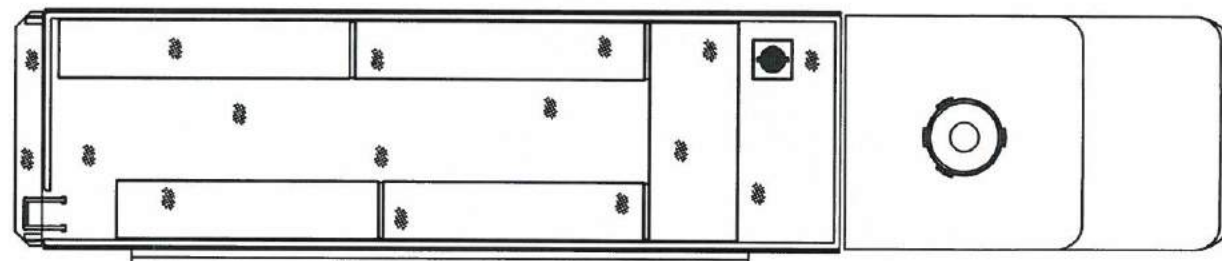

ROOF VIEW

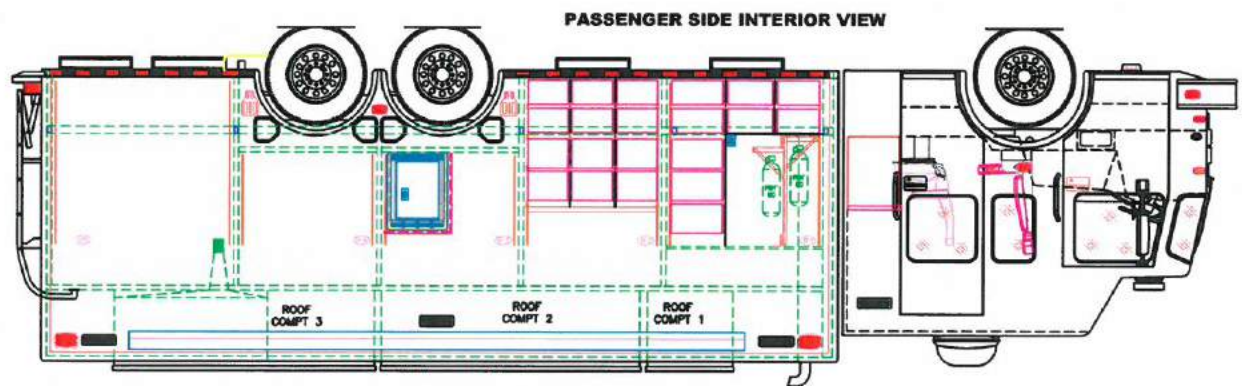

PASSENGER SIDE INTERIOR VIEW

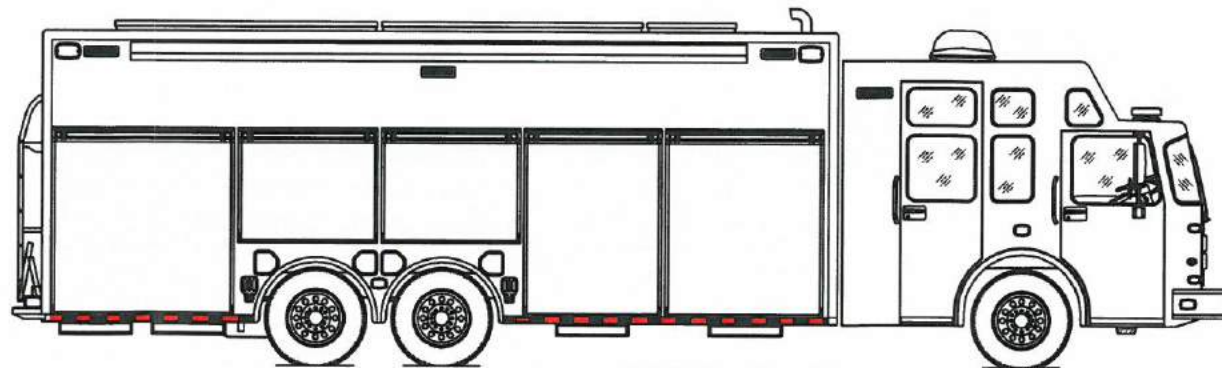

PASSENGER SIDE VIEW

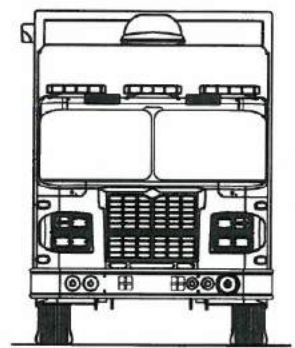

FARBER
SPECIALTY VEHICLES
7551 AMERICANA PARKWAY
COLUMBUS, OH 43068
USA

| | | | | | |
|-------------------------------------|-----|-------------|---------------------------|------|------|
| DATE | REV | DESCRIPTION | BY | CHKD | DATE |
| | | | | | |
| PROPERTY OF US COMMUNITIES 16400 | | | SCALE: 1:24 SHEET: A.1 | | |

FSV TRAILER 53' MOBILE TRAINING CLASSROOM

53' trailer, aluminum skin trailer with two aluminum constructed entry/exit doors. Custom aluminum detachable steps with handrails. 36' shoreline connection. Five roof mounted air conditioners located to evenly cool all areas. Electric heat and full length fluorescent lighting. Twenty-one work stations including instructors area. Storage closet. Commercial grade vinyl flooring. Custom options for restroom, ADA accessibility, additional entrances and awnings. See price sheet for details and packages.



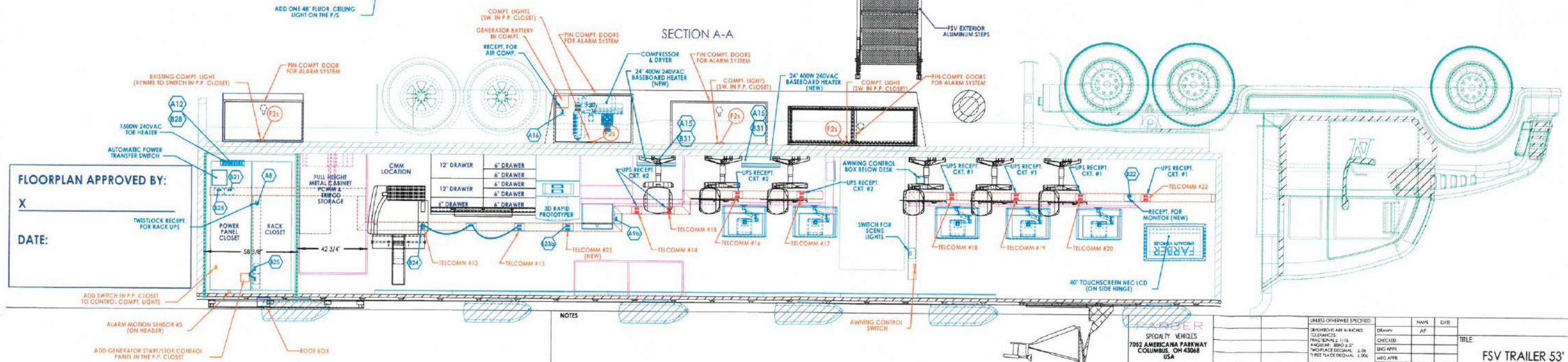
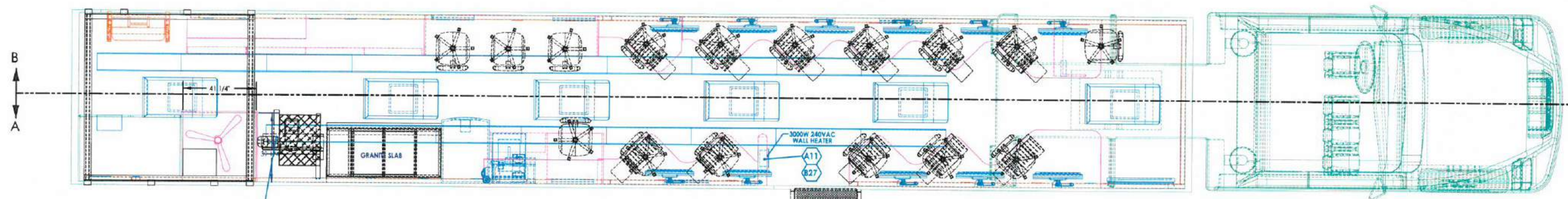
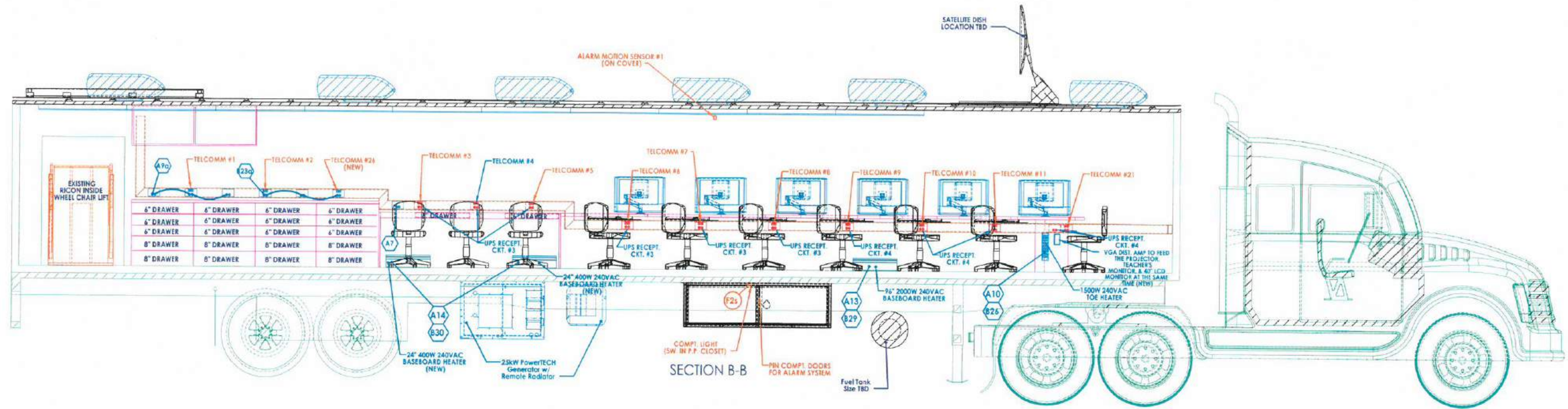

FLOORPLAN APPROVED BY:
X
DATE:

NOTES

| REVISIONS | ZONE | REV. | DATE | APPROVED |
|-----------|------|------|------|----------|
| | | | | |

FARBER
SPECIALTY VEHICLES
7032 AMERICANA PARKWAY
COLUMBUS, OH 43248
USA

PROPERTY AND CONFIDENTIAL
THE INFORMATION CONTAINED IN THIS DRAWING IS THE SOLE PROPERTY OF FARBER SPECIALTY VEHICLES. NO PART OF THIS DRAWING IS TO BE REPRODUCED OR TRANSMITTED IN ANY FORM OR BY ANY MEANS WITHOUT THE WRITTEN PERMISSION OF FARBER SPECIALTY VEHICLES. © 2006

| UNLESS OTHERWISE SPECIFIED: | NAME | DATE |
|-----------------------------|------|------|
| DRAWINGS ARE IN INCHES | | |
| TOLERANCES | | |
| FRACTIONS 2/116 | | |
| ANGLES 30° 45° 60° 90° | | |
| THREE PLACE DECIMAL 2.00 | | |
| THREE PLACE DECIMAL 2.006 | | |
| REVISIONS | | |
| DATE | | |
| BY | | |
| CHECKED | | |
| DATE | | |
| BY | | |
| CHECKED | | |
| DATE | | |
| BY | | |
| CHECKED | | |
| DATE | | |
| BY | | |

| | | |
|----------|------------------------|------------|
| TITLE: | FSV TRAILER 53' | |
| SIZE | Part Number | REV |
| D | 15580 | A.7 |
| WEIGHT: | SHEET 1 OF 1 | |

MODEL: FSV BODY 18 MOBILE MEDICAL HEALTH VEHICLE

Body 18', 27' overall length, 6.7L diesel powered, 19,500 GVWR, 40 gallon fuel tank, 102" exterior width, aluminum/galvanized steel body construction. Class "A" fire rated fiberglass interior wall and ceiling finish, commercial vinyl flooring. Roof air conditioner, electric heat, magnetic/hydraulic 12V circuit breakers, electronic master disconnect switches for main and auxiliary battery system, 36' shoreline. Custom cabinets cut using CNC router.

Space is designed for efficiency and ergonomic function for an optimized workflow. Floor plan includes one room, intake/reception area, waiting area and lab area. Custom options for restroom, ADA accessibility, testing equipment, additional entrances and awnings. Alternative length options available. 4-wheel drive option available. See price sheet for details.



MODEL: FSV BODY 18 MOBILE OUTREACH COUNSELING

Body 18', 27' overall length, 6.7L diesel powered, 19,500 GVWR, 40 gallon fuel tank, 102" exterior width, aluminum body construction. Class "A" fire rated fiberglass interior wall and ceiling finish, commercial one piece vinyl flooring. 15,000 BTU roof air conditioner, electric heat, magnetic/hydraulic 12V and 120V circuit breakers, electronic master disconnect switches for main and auxiliary battery system, 36' shoreline. Sofa/sleeper, two drawer locking file cabinet, removable table located in counseling area. Ergonomic office style chairs provided for each work station. Other features include; two emergency exit windows, roof access ladder, electronics closet with power fan, smoke/CO alarms. Custom cabinets cut using CNC router include locks keyed alike. 4-wheel drive option available.



MODEL: FSV BODY 20 MOBILE DENTAL VEHICLE

20'Box, 29' overall length, 260 hp diesel engine, 26,000 GVWR, Allison 2500 RDS automatic 5 speed, 60 gallon fuel tank, two air conditioners. Magnetic/hydraulic 12V circuit breakers, electronic master disconnect switches for main and auxiliary battery system, 36' shoreline. Commercial / medical grade vinyl flooring. Electric heat, automatic computerized hydraulic leveling/stabilizing system, magnetic/hydraulic 12V circuit breakers, electronic master disconnect switches for main and auxiliary battery system, 90 amp. converter, 36' shoreline. Custom cabinets cut using CNC router.

Space is designed for efficiency and ergonomic function for an optimized workflow. Floorplan includes one or two operatories, intake/reception area, waiting area and sterilization center. Custom options for restroom, ADA accessibility, additional entrances and awnings. See price sheet for details and packages of dental chairs, X-rays, sterilization and other dental equipment. See price sheet for details. Alternative length options available.



MODEL: FSV BODY 20 BLOODMOBILE

20'Box, 29' overall length, 260 hp diesel engine, 26,000 GVWR, Allison 2500 RDS automatic 5 speed, 60 gallon fuel tank, two air conditioners. Magnetic/hydraulic 12V circuit breakers, electronic master disconnect switches for main and auxiliary battery system, 36' shoreline. Commercial / medical grade vinyl flooring. Electric heat, automatic computerized hydraulic leveling/stabilizing system, magnetic/hydraulic 12V circuit breakers, electronic master disconnect switches for main and auxiliary battery system, 90 amp. converter, 36' shoreline. Custom cabinets cut using CNC router.

Space is designed for efficiency and ergonomic function for an optimized workflow. Floorplan includes two blood draw tables, screening room, waiting area and lab area. Custom options for restroom, additional entrances and awnings. See price sheet for details. Alternative length options available.

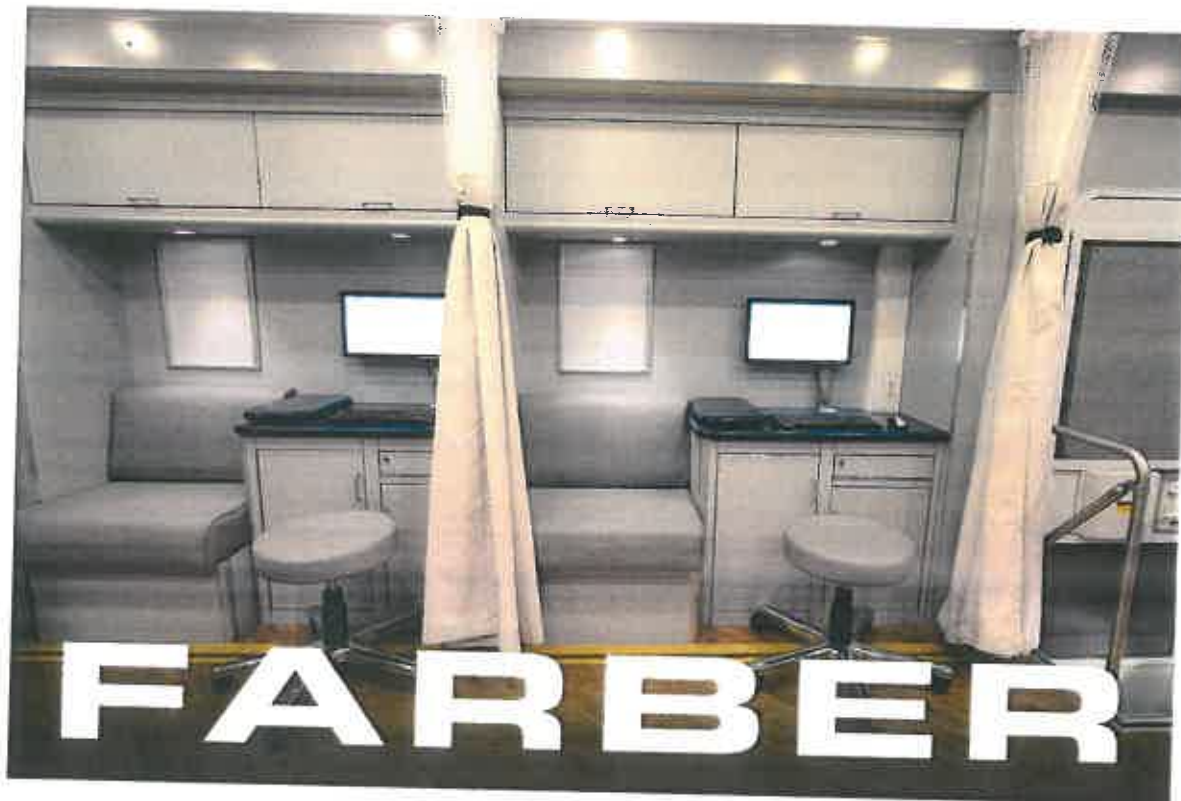

**MODEL: FSV BODY 20
PATIENT - PASSENGER TRANSPORT**

29' overall length, diesel powered, 26,000 GVWR, 102" exterior width, 10Kw diesel generator, 100 gallon fuel tank, Altoona tested steel cage construction. ADA approved wheelchair lift, ramp access to accommodate litter bearing team. Mechanisms provided to secure and support standard NATO litters and for securing "H" size portable oxygen cylinders. Longitudinal overhead cabinets provided for storage. Refrigerator, LED clock, privacy curtains. 120 volt roof air conditioning, front and rear automotive air conditioning. Overall length options available.



**MODEL: FSV BODY 24
PRISONER TRANSPORT**

Body 24', 32' overall length, 24 passenger, diesel powered, 22,000 GVWR, 98" exterior width, 50 gallon fuel tank, cage and security wall doors locked with heavy lock & keyed alike keys, movable security wall with pass through door. Trans-Air A/C and heat, 110K BTU system with evaporator, (2) two fans, (3) three fan skirt mount condensers. Forced air heat designed to distribute an even amount of heat to all areas. Pro-Lo escape hatch with security screen.



**MODEL: FSV BODY 30
COMMAND – COMMUNICATIONS – EOD –**

39' overall length, 325 hp diesel engine, 33,000 GVWR, Allison 3000 EVS automatic 6 speed air brake package, 60 gallon fuel tank, three air conditioners, group 31 deep-cycle batteries, interior LED light package, magnetic/hydraulic 12V and 120V circuit breakers, electronic master disconnect switches for main and auxiliary battery system, 36' shoreline. Six workstations, conference room, Custom cabinets cut using CNC router. Whiteboard finish on overhead cabinet doors. Optional tandem axle available.



**MODEL: FSV BODY 30
COMMAND – COMMUNICATIONS – EOD –**

39' overall length, 325 hp diesel engine, 33,000 GVWR, Allison 3000 EVS automatic 6 speed air brake package, 60 gallon fuel tank, three air conditioners, group 31 deep-cycle batteries, interior LED light package, magnetic/hydraulic 12V and 120V circuit breakers, electronic master disconnect switches for main and auxiliary battery system, 36' shoreline. Six workstations, conference room, Custom cabinets cut using CNC router. Whiteboard finish on overhead cabinet doors. Optional tandem axle available.



**MODEL: FSV BODY 30
COMMAND – COMMUNICATIONS – EOD –**

39' overall length, 325 hp diesel engine, 33,000 GVWR, Allison 3000 EVS automatic 6 speed air brake package, 60 gallon fuel tank, three air conditioners, group 31 deep-cycle batteries, interior LED light package, magnetic/hydraulic 12V and 120V circuit breakers, electronic master disconnect switches for main and auxiliary battery system, 36" shoreline. Six workstations, conference room, Custom cabinets cut using CNC router. Whiteboard finish on overhead cabinet doors. Optional tandem axle available.



MODEL: FSV BODY 32 MOBILE DENTAL VEHICLE

39' overall length, 325 hp diesel engine, 33,000 GVWR, Allison 3000 RDS automatic 6 speed, air brake package, 60 gallon fuel tank, three air conditioners, group 31 deep-cycle batteries, magnetic/hydraulic 12V circuit breakers, electronic master disconnect switches for main and auxiliary battery system, 36' shoreline. Commercial / medical grade vinyl flooring. Electric heat, automatic computerized hydraulic leveling/stabilizing system, magnetic/hydraulic 12V circuit breakers, electronic master disconnect switches for main and auxiliary battery system, 90 amp. converter, 36' shoreline. Custom cabinets cut using CNC router.

Space is designed for efficiency and ergonomic function for an optimized workflow. Floorplan includes two or three operatories, intake/reception area, waiting area and sterilization center. Custom options for restroom, ADA accessibility, additional entrances and awnings. See price sheet for details and packages of dental chairs, X-rays, sterilization and other dental equipment. See price sheet for details. Alternative length options available.



MODEL: FSV BODY 32 MOBILE MEDICAL HEALTH VEHICLE

39' overall length, 325 hp diesel engine, 33,000 GVWR, Allison 3000 RDS automatic 6 speed, air brake package, 60 gallon fuel tank, three air conditioners, group 31 deep-cycle batteries, magnetic/hydraulic 12V circuit breakers, electronic master disconnect switches for main and auxiliary battery system, 36' shoreline. Commercial / medical grade vinyl flooring. Electric heat, automatic computerized hydraulic leveling/stabilizing system, magnetic/hydraulic 12V circuit breakers, electronic master disconnect switches for main and auxiliary battery system, 90 amp. converter, 36' shoreline. Custom cabinets cut using CNC router.

Space is designed for efficiency and ergonomic function for an optimized workflow. Floorplan includes two exam rooms, intake/reception area, waiting area and lab area. Custom options for restroom, ADA accessibility, testing equipment, additional entrances and awnings. See price sheet for details. Alternative length options available.



FSV BODY 32 MOBILE MAMMOGRAPHY CAB/CHASSIS

40' overall length, 330 hp Cummins ISC diesel engine, 54,600 GVWR, 40,000 lb. tandem rear axle w/ airliner suspension, 14,600 lb. front suspension, Allison 3000 RDS automatic 6-speed, driver controlled traction differential, 270 amp alternator, air brake package w/ air dryer heater, dual 50 gallon fuel tanks w/ heaters, chromed steel bumper, aluminum outside wheels, air horns, power heated mirrors, electric door locks, air suspension driver and passenger seats w/ armrests, adjustable tilt steering column, AM/FM/CD/MP3 radio. Aluminum exterior skin, centrally ducted air conditioning, custom light package, magnetic/hydraulic 12V and 120V circuit breakers, electronic master disconnect switches for main and auxiliary battery system, 36' shoreline. Custom cabinetry manufactured using CNC router.

Space is designed for efficiency and ergonomic function for an optimized workflow. Floorplan includes, screening room, waiting/reception area, changing room(s). Custom options for restroom, ADA accessibility, Digital Environmental Control System. Ready for Analog or Digital X-ray installation.



**MODEL: FSV BODY 32
PRISONER TRANSPORT**

Body 32', 42' overall length, 36 passenger, diesel powered, 33,000 GVWR, 98" exterior width, 50 gallon fuel tank, cage and security wall doors locked with heavy lock & keyed alike keys, movable security wall with pass through door. Trans-Air A/C and heat 110K BTU system with evaporator, (2) two fans, (3) three fan skirt mount condensers. Forced air heat designed to distribute an even amount of heat to all areas. Pro-Lo escape hatch with security screen.



FARBER

MODEL: FSV STEPVAN 20 Mobile Command

29' 6" overall length, Freightliner MT-55 chassis, Cummins 6.7L, 260HP diesel front engine, 26,000 GVWR. Allison 2500 series automatic transmission. Aluminum body construction with chrome front bumper, air brake package with ABS, 60 gallon fuel tank, power steering, remote control, heated exterior cab mirrors, two dashboard controlled electric windshield fans, Magnum high-back swivel driver and passenger seats, overhead storage cabinets. Commercial grade vinyl flooring two roof air conditioners, electric heat, 12V magnetic/hydraulic circuit breakers, electronic master disconnect switches for main and auxiliary battery system, 90 amp. converter, 36' shoreline. Custom cabinets cut using CNC router.

Space is designed for efficiency and ergonomic function for an optimized workflow. Custom options for restroom, additional entrances and awnings. See price sheet for details.



MODEL: FSV STEPVAN 30 MOBILE DENTAL CLINIC

39' 6" overall length, Freightliner MT-55 chassis, Cummins 6.7L, 300HP diesel front engine, 29,000 GVWR. Allison 2500 series automatic transmission, Aluminum body construction with chrome front bumper, air brake package with ABS, 90 gallon fuel tank, power steering, remote control, heated exterior cab mirrors, two dashboard controlled electric windshield fans, dash monitor for rearview backup camera system, Magnum high-back swivel driver and passenger seats, overhead storage cabinets. Commercial/medical grade vinyl flooring three roof air conditioners, electric heat, 12V magnetic/hydraulic circuit breakers, electronic master disconnect switches for main and auxiliary battery system, 90 amp. converter, 36' shoreline. Custom cabinets cut using CNC router.

Space is designed for efficiency and ergonomic function for an optimized workflow. Floor plan includes two operatories, intake/reception area, waiting area and sterilization center. Custom options for restroom, ADA accessibility, additional entrances and awnings. See price sheet for details and packages of dental chairs, X-rays, sterilization and other dental equipment.



MODEL: FSV STEPVAN 30 BLOODMOBILE

39' 6" overall length, Freightliner MT-55 chassis, Cummins 6.7L, 300HP diesel front engine, 29,000 GVWR. Allison 2500 series automatic transmission. Aluminum body construction with chrome front bumper, air brake package with ABS, 90 gallon fuel tank, power steering, remote control, heated exterior cab mirrors, two dashboard controlled electric windshield fans, Magnum high-back swivel driver and passenger seats, overhead storage cabinets. Commercial/medical grade vinyl flooring three roof air conditioners, electric heat, 12V magnetic/hydraulic circuit breakers, electronic master disconnect switches for main and auxiliary battery system, 90 amp. converter, 36' shoreline. Custom cabinets cut using CNC router.

Space is designed for efficiency and ergonomic function for an optimized workflow. Floor plan includes four blood draw tables, screening room, waiting area and lab area. Custom options for restroom, additional entrances and awnings. See price sheet for details.



MODEL: FSV STEPVAN 30 BOOKMOBILE

39' 6" overall length, Freightliner MT-55 chassis, Cummins 6.7L, 300HP diesel front engine, 29,000 GVWR. Allison 2500 series automatic transmission. Aluminum body construction with chrome front bumper, air brake package with ABS, 90 gallon fuel tank, power steering, remote control, heated exterior cab mirrors, two dashboard controlled electric windshield fans, Magnum high-back swivel driver and passenger seats, overhead storage cabinets. Commercial/medical grade vinyl flooring three roof air conditioners, electric heat, 12V magnetic/hydraulic circuit breakers, electronic master disconnect switches for main and auxiliary battery system, 90 amp. converter, 36' shoreline. Custom cabinets cut using CNC router.

Space is designed for efficiency and ergonomic function for an optimized workflow. Floor plan includes four blood draw tables, screening room, waiting area and lab area. Custom options for restroom, additional entrances and awnings. See price sheet for details.



MODEL: FSV COACH STYLE 33 MOBILE COMMAND

33'6" overall length, 6.8L, 362HP, gasoline powered, 24,000 GVWR, 75 gallon fuel tank, 102" exterior width, aluminum frame body construction, fiberglass exterior, flat interior floor/ no wheel wells, drivers door, main entrance door equipped with electric steps, aluminum outer wheels,. Remote control, heated exterior cab mirrors. High back, swivel, driver and passenger seats. Two dashboard controlled electric windshield fans. Commercial / medical grade vinyl flooring. Three roof air conditioners with central ducting, electric heat, magnetic/hydraulic 12V circuit breakers, electronic master disconnect switches for main and auxiliary battery system, 90 amp. converter, 36' shoreline. Custom cabinets cut using CNC router.

Space is designed for efficiency and ergonomic function for an optimized workflow. Floor plan includes two exam rooms, intake/reception area, waiting area and lab area. Custom options for restroom, ADA accessibility, testing equipment, additional entrances and awnings. See price sheet for details.



MODEL: FSV COACH STYLE 33 MOBILE COMMAND

33'6" overall length, 6.8L, 362HP, gasoline powered, 24,000 GVWR, 75 gallon fuel tank, 102" exterior width, aluminum frame body construction, fiberglass exterior, flat interior floor/ no wheel wells, drivers door, main entrance door equipped with electric steps, aluminum outer wheels,. Remote control, heated exterior cab mirrors. High back, swivel, driver and passenger seats. Two dashboard controlled electric windshield fans. Commercial / medical grade vinyl flooring. Three roof air conditioners with central ducting, electric heat, magnetic/hydraulic 12V circuit breakers, electronic master disconnect switches for main and auxiliary battery system, 90 amp. converter, 36' shoreline. Custom cabinets cut using CNC router.

Space is designed for efficiency and ergonomic function for an optimized workflow. Floor plan includes two exam rooms, intake/reception area, waiting area and lab area. Custom options for restroom, ADA accessibility, testing equipment, additional entrances and awnings. See price sheet for details.



MODEL: FSV COACH STYLE 38 MOBILE MEDICAL HEALTH VEHICLE

38'6" overall length, 6.8L, 362HP, gasoline powered, 24,000 GVWR, 75 gallon fuel tank, 102" exterior width, aluminum frame body construction, fiberglass exterior, flat interior floor/ no wheel wells, drivers door, main entrance door equipped with electric steps, aluminum outer wheels,. Remote control, heated exterior cab mirrors. High back, swivel, driver and passenger seats. Two dashboard controlled electric windshield fans. Commercial / medical grade vinyl flooring. Three roof air conditioners with central ducting, electric heat, magnetic/hydraulic 12V circuit breakers, electronic master disconnect switches for main and auxiliary battery system, 90 amp. converter, 36' shoreline. Custom cabinets cut using CNC router.

Space is designed for efficiency and ergonomic function for an optimized workflow. Floor plan includes two exam rooms, intake/reception area, waiting area and lab area. Custom options for restroom, ADA accessibility, testing equipment, additional entrances and awnings. See price sheet for details.



MODEL: FSV COACH STYLE 38 MOBILE OUTREACH COUNSELING

38'6" overall length, 6.7L Cummins, 340HP diesel engine, 26,000 GVWR, 80 gallon fuel tank, 102" exterior width, aluminum frame body construction, fiberglass exterior, flat interior floor/ no wheel wells, drivers door, main entrance door equipped with electric steps, aluminum outer wheels, Remote control, heated exterior cab mirrors. High back, swivel, driver and passenger seats. Two dashboard controlled electric windshield fans. Commercial one-piece vinyl flooring. Three roof air conditioners with central ducting, electric heat, magnetic/hydraulic 12V and 120V circuit breakers, electronic master disconnect switches for main and auxiliary battery system, 90 amp. converter, 36' shoreline. Custom cabinets with locking doors, keyed alike. Sofa/sleeper, two drawer locking file cabinet, removable table located in each counseling room. Sliding pocket doors to separate each counseling room. Ergonomic office style chairs provided for each workstation.



MODEL: FSV CUSTOM COACH 40- (REAR ENGINE) BLOODMOBILE

39' overall length, 325 hp diesel engine, 33,000 GVWR, Allison 3000 RDS automatic 6 speed, air brake package, 60 gallon fuel tank, three air conditioners, group 31 deep-cycle batteries, magnetic/hydraulic 12V circuit breakers, electronic master disconnect switches for main and auxiliary battery system, 36' shoreline. Commercial / medical grade vinyl flooring. Electric heat, automatic computerized hydraulic leveling/stabilizing system, magnetic/hydraulic 12V circuit breakers, electronic master disconnect switches for main and auxiliary battery system, 90 amp. converter, 36' shoreline. Custom cabinets cut using CNC router.

Space is designed for efficiency and ergonomic function for an optimized workflow. Floorplan includes four blood draw tables, screening room(s), waiting area and lab area. Custom options for restroom, additional entrances and awnings. See price sheet for details. Alternative length options available.



MODEL: FSV CUSTOM COACH STYLE 40 –(REAR ENGINE) MOBILE MAMMOGRAPHY COACH

41'4" overall length, 8.3L, Cummins 400HP, diesel powered, rear engine, 33,000 GVWR, Allison 6-speed automatic, full air-suspension, air disc brakes, independent front suspension, 101" exterior width, aluminum frame body construction, fiberglass exterior, flat interior floor/ no wheel wells, main entrance door equipped with electric steps, aluminum outer wheels. Remote control, heated exterior cab mirrors. High back, swivel, driver and passenger seats. Two dashboard controlled electric windshield fans. Built in dash monitor for rearview backup camera system. Commercial/medical grade vinyl flooring. Three roof air conditioners, electric heat, automatic computerized hydraulic leveling/stabilizing system, magnetic/hydraulic 12V circuit breakers, electronic master disconnect switches for main and auxiliary battery system, 90 amp. converter, 36" shoreline. Custom cabinets cut using CNC router.

Space is designed for efficiency and ergonomic function for an optimized workflow. Floorplan includes, screening room, waiting/reception area, changing room(s). Custom options for restroom, ADA accessibility, additional entrances, awnings, upgraded interior, Digital Environmental Control System and interior lighting. Ready for Analog or Digital X-ray installation. See price sheet for details. Alternative length options available.



MODEL: FSV CUSTOM COACH STYLE 40 (REAR ENGINE) MOBILE MEDICAL HEALTH VEHICLE

41'4" overall length, 8.3L, Cummins 400HP, diesel powered, rear engine, 33,000 GVWR, Allison 6-speed automatic, tank, full air-suspension, air disc brakes, independent front suspension, 101" exterior width, coach style, aluminum frame body construction, fiberglass exterior, flat interior floor/ no wheel wells, main entrance door equipped with electric steps, aluminum outer wheels. Remote control, heated exterior cab mirrors. High back, swivel, driver and passenger seats. Two dashboard controlled electric windshield fans. Built in dash monitor for rearview backup camera system. Commercial/medical grade vinyl flooring. Three roof air conditioners, electric heat, automatic computerized hydraulic leveling/stabilizing system, magnetic/hydraulic 12V circuit breakers, electronic master disconnect switches for main and auxiliary battery system, 90 amp. converter, 36' shoreline. Custom cabinets cut using CNC router.

Space is designed for efficiency and ergonomic function for an optimized workflow. Floorplan includes two exam rooms, intake/reception area, waiting area and lab area. Custom options for restroom, ADA accessibility, testing equipment, additional entrances and awnings. See price sheet for details.



**MODEL: FSV PREVOST X3-45' (REAR ENGINE)
Mobile Command, Medical, Classroom**

Full air-suspension, air disc brakes, independent front suspension, 101" exterior width, aluminum frame body construction, aluminum exterior, flat interior floor/ no wheel wells, main entrance door equipped with electric steps, aluminum outer wheels. Remote control, heated exterior cab mirrors. High back, swivel, driver and passenger seats. Two dashboard controlled electric windshield fans. Commercial/medical grade vinyl flooring. Three roof air conditioners, electric heat, magnetic/hydraulic 12V circuit breakers, electronic master disconnect switches for main and auxiliary battery system, 90 amp. Converter, 36' shoreline. Custom cabinets cut using CNC router.

Space is designed for efficiency and ergonomic function for an optimized workflow. Custom options for restroom, additional entrances, slide-outs and awnings. See price sheet for details.



FSV TRAILER 20 MOBILE MEDICAL HEALTH – DENTAL -

Body 20', 24' overall length, 10,000 GVWR, 102" exterior width, Aluminum construction, welded safety chains. Two tinted, 30" x 22" windows, day/night shades installed on windows. One grab handle at door location. Deluxe scissor jacks with hand crank. Fire rated fiberglass interior wall and ceiling finish, commercial/medical vinyl flooring. One roof mounted air conditioner, electric heat. 12V and 120V circuit breakers, electronic master disconnect switches for main and auxiliary battery system, 36' shoreline. Custom cabinets cut using CNC router.

Space is designed for efficiency and ergonomic function for an optimized workflow. Floorplan includes one or two exam rooms, intake/reception area, waiting area and lab area. Custom options for restroom, ADA accessibility, testing equipment, additional entrances and awnings. See price sheet for details. Alternative length options available.



FSV TRAILER 53' MOBILE MEDICAL HEALTH – DENTAL

53' trailer, aluminum skin trailer, Custom aluminum entrance doors w/removable steps and handrails. Four AC units, electronic thermostats in each zone. Galley with under counter refrigerator, coffee maker and cabinet installed microwave. Interior LED lighting. Interior is a multi-use space for medical screening, bloodmobile, dental clinic, lab or combination. Quartz Halogen scene lights provided for entry areas. See price sheet for available equipment packages.

Space is designed for efficiency and ergonomic function for an optimized workflow. Floorplan includes three or four exam rooms/operators, intake/reception area, waiting area and lab area. Custom options for restroom, ADA accessibility, testing equipment, additional entrances and awnings. Alternative length options available.



FSV TRAILER DOUBLE EXPANDABLE TRAILER 53'

53' double expandable aluminum constructed trailer. 30' x 7' expandable section to provide 634 total square feet of floor space. Expandable provides flat floor transition between main body w/ hydraulic power. Central ceiling ducted HVAC system. Aluminum belly boxes for exterior storage w/ Rhino liner protection. 200 AMP, 240/120V electrical service. Full interior LED lighting package. Five-ton HVAC unit, 56,000 BTU's w/ 9Kw heat, electronic thermostat. Custom aluminum entrance doors and steps w/ handrails. Interior is a multi-use space for medical screening, bloodmobile, dental clinic, lab or combination. See price sheet for available equipment packages.



FSV TRAILER DOUBLE EXPANDABLE TRAILER 53'

53' double expandable aluminum constructed trailer. 30' x 7' expandable section to provide 634 total square feet of floor space. Expandable provides flat floor transition between main body w/ hydraulic power. Central ceiling ducted HVAC system. Aluminum belly boxes for exterior storage w/ Rhino liner protection. 200 AMP, 240/120V electrical service. Full interior LED lighting package. Five-ton HVAC unit, 56,000 BTU's w/ 9Kw heat, electronic thermostat. Custom aluminum entrance doors and steps w/ handrails. Interior is a multi-use space for medical screening, bloodmobile, dental clinic, lab or combination. See price sheet for available equipment packages.



**FSV TRAILER
TWO STORY TRAILER -
EOC - COMMAND - COMMUNICATIONS 53'**

53' two story, quad slide trailer, aluminum frame construction, 6 wheel disc brakes with anti-lock braking system, tridem wheel configuration. Slides feature dual air system and low friction precision bearing rails. Raised roof powered by electric actuators. Rear and side entry doors. Windows feature double pane "Low-E" glass with tinted finish. Full stand up upper floor with access to optional roof deck. Dual zone climate control system with 10 tons cooling high velocity air conditioning. 20Kw heat capacity. Custom designed workstations, private conference room, Full interior LED lighting package. 942 sq. ft. of floor area including main and second floor. 250 sq. ft. of deck area with sturdy powder coated aluminum rails (optional). Total set up time is approximately 20 minutes.



MULTI-USE CONTAINER MODULE 10'

10' overall length, exterior width 96", interior height 82", International Shipping Container, single trip, almost new condition, one piece steel roof. Full width double-door access on one end. 3/4" plywood floor, 120/240 50 amp, 36' shoreline, Marisco waterproof shoreline connector. Polystyrene insulation, 3/4" plywood sub-walls, commercial vinyl or rubber floor.

Interior can be upfitted for a variety of applications: office, medical, command, lab, training or other use. See price sheet for detail of options. Some custom work may be required.



MULTI-USE CONTAINER MODULE 20'

20' overall length, exterior width 96", interior height 82", International Shipping Container, single trip, almost new condition, one piece steel roof. Full width double-door access on one end. 3/4" plywood floor, 120/240 volt 50 amp, 36' shoreline, Marince waterproof shoreline connector. Polystyrene insulation, 3/4" plywood sub-walls, commercial vinyl or rubber floor.

Interior can be upfitted for a variety of applications: office, medical, command, lab, training or other use. See price sheet for detail of options. Some custom work may be required.



MULTI-USE CONTAINER MODULE 40'

40' overall length, exterior width 96", interior height 82", International Shipping Container, single trip, almost new condition, one piece steel roof. Full width double-door access on one end. $\frac{3}{4}$ " plywood floor, 120/240 volt 50 amp, 36' shoreline, Marinco waterproof shoreline connector. Polystyrene insulation, $\frac{3}{4}$ " plywood sub-walls, commercial vinyl or rubber floor.

Interior can be upfitted for a variety of applications: office, medical, command, lab, training or other use. See price sheet for detail of options. Some custom work may be required.



**MODEL: FSV VAN
EVIDENCE COLLECTION - CRIME SCENE 16'**

16' overall length, 2.0 Duratec DOHC I-4, 1600lb Payload, 15 gallon fuel tank, 71" exterior width, steel unibody construction, heavy duty spray on commercial flooring. Body shall have two (2) swing out rear doors with windows. Cabinets located on both sides of the unit designed for storage of evidence collection kit. All interior lights to be LED. The final finishing of this vehicle shall be to commercial truck standards.



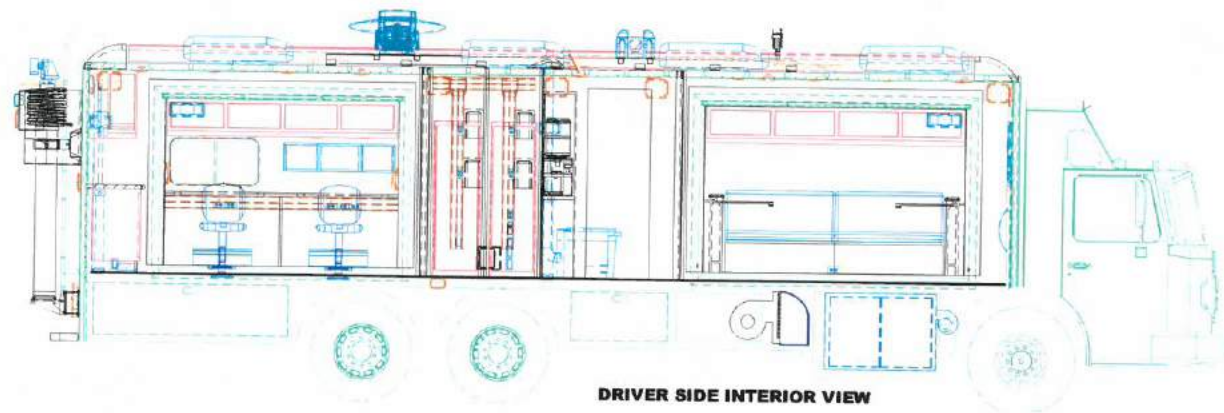

DRIVER SIDE INTERIOR VIEW

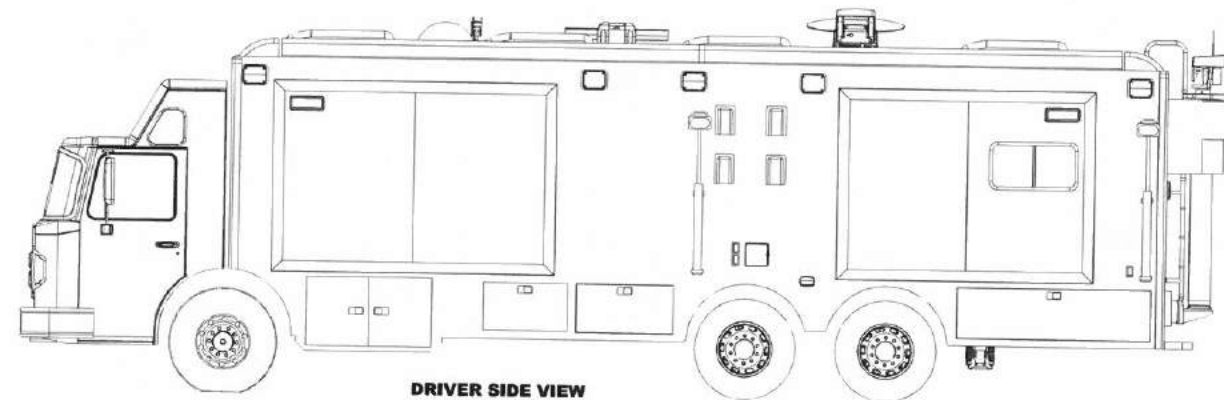

DRIVER SIDE VIEW

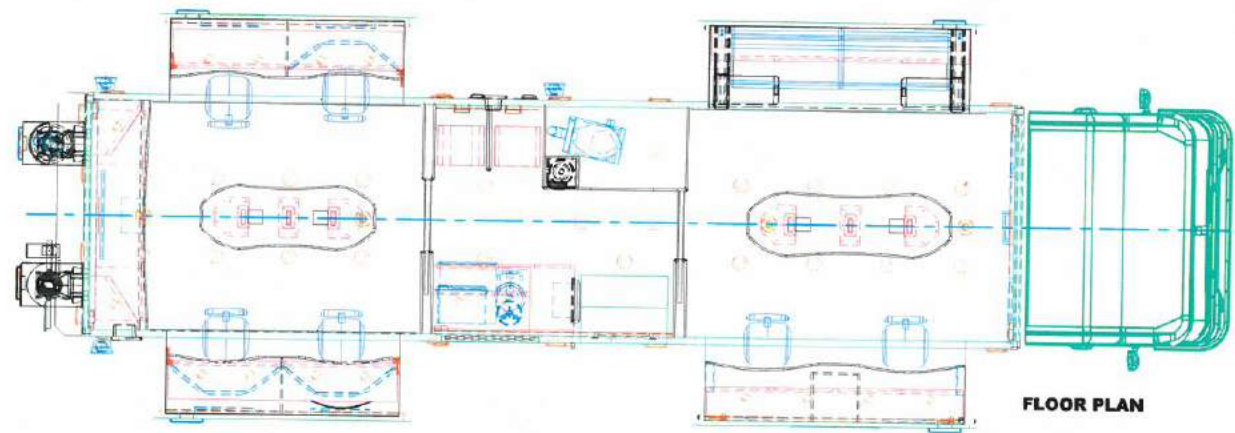

FLOOR PLAN

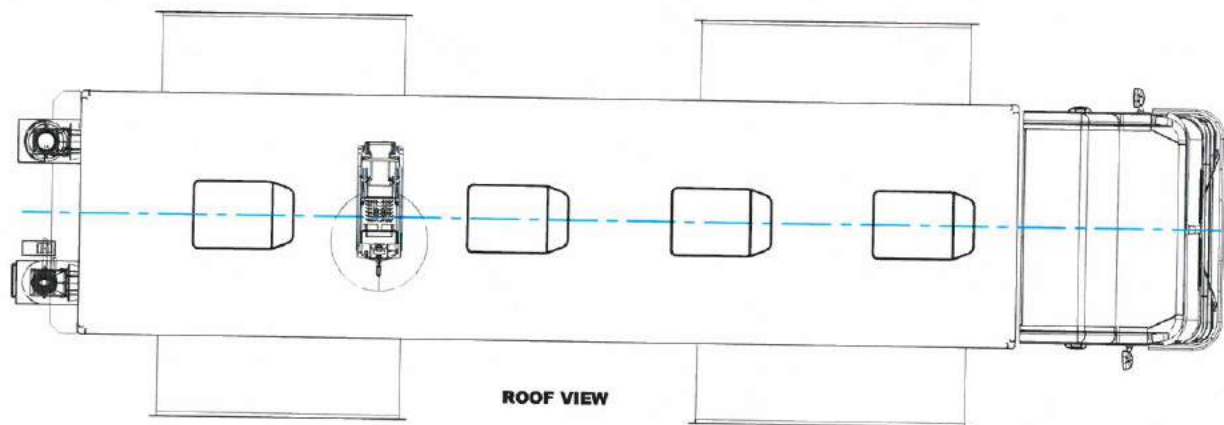

ROOF VIEW

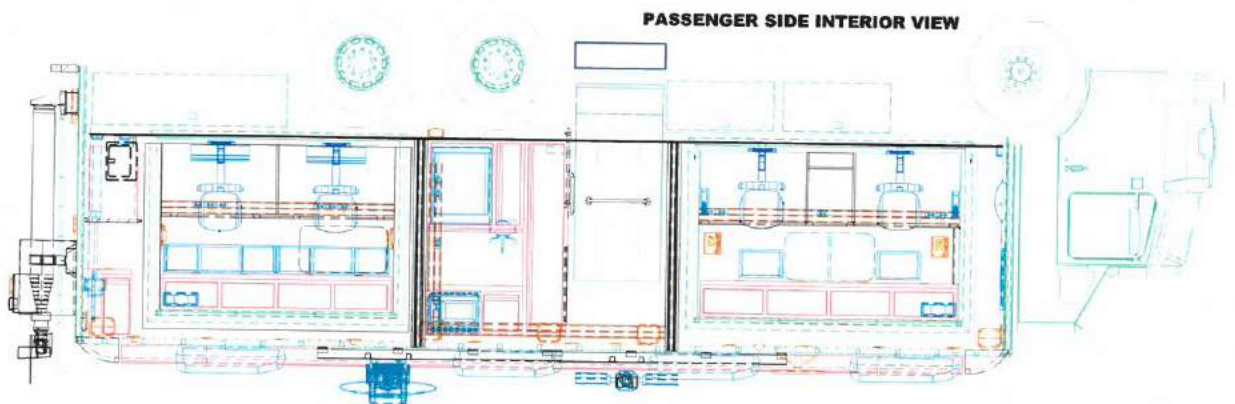
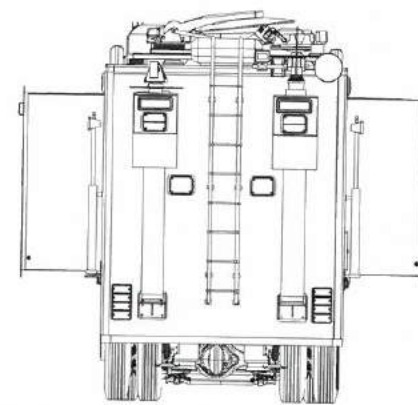

PASSENGER SIDE INTERIOR VIEW



PASSENGER SIDE VIEW

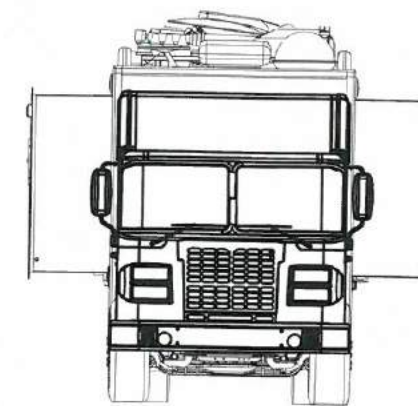

| | |
|-------------------|--|
| Customer Approval | |
| Drawn | |
| Checked | |

FARBER
SPECIALTY VEHICLES
7052 AMERICANA PARKWAY
COLUMBUS, OH 43068
USA

| | | | | |
|-----|----------------------|----------|---------|-----|
| REV | DESCRIPTION | DATE | BY | APP |
| 1 | ISSUE FOR PRODUCTION | 11/11/14 | D. HAAG | |
| 2 | REVISION | | | |
| 3 | REVISION | | | |
| 4 | REVISION | | | |
| 5 | REVISION | | | |
| 6 | REVISION | | | |
| 7 | REVISION | | | |
| 8 | REVISION | | | |
| 9 | REVISION | | | |
| 10 | REVISION | | | |
| 11 | REVISION | | | |
| 12 | REVISION | | | |
| 13 | REVISION | | | |
| 14 | REVISION | | | |
| 15 | REVISION | | | |
| 16 | REVISION | | | |
| 17 | REVISION | | | |
| 18 | REVISION | | | |
| 19 | REVISION | | | |
| 20 | REVISION | | | |
| 21 | REVISION | | | |
| 22 | REVISION | | | |
| 23 | REVISION | | | |
| 24 | REVISION | | | |
| 25 | REVISION | | | |
| 26 | REVISION | | | |
| 27 | REVISION | | | |
| 28 | REVISION | | | |
| 29 | REVISION | | | |
| 30 | REVISION | | | |
| 31 | REVISION | | | |
| 32 | REVISION | | | |
| 33 | REVISION | | | |
| 34 | REVISION | | | |
| 35 | REVISION | | | |
| 36 | REVISION | | | |
| 37 | REVISION | | | |
| 38 | REVISION | | | |
| 39 | REVISION | | | |
| 40 | REVISION | | | |
| 41 | REVISION | | | |
| 42 | REVISION | | | |
| 43 | REVISION | | | |
| 44 | REVISION | | | |
| 45 | REVISION | | | |
| 46 | REVISION | | | |
| 47 | REVISION | | | |
| 48 | REVISION | | | |
| 49 | REVISION | | | |
| 50 | REVISION | | | |
| 51 | REVISION | | | |
| 52 | REVISION | | | |
| 53 | REVISION | | | |
| 54 | REVISION | | | |
| 55 | REVISION | | | |
| 56 | REVISION | | | |
| 57 | REVISION | | | |
| 58 | REVISION | | | |
| 59 | REVISION | | | |
| 60 | REVISION | | | |
| 61 | REVISION | | | |
| 62 | REVISION | | | |
| 63 | REVISION | | | |
| 64 | REVISION | | | |
| 65 | REVISION | | | |
| 66 | REVISION | | | |
| 67 | REVISION | | | |
| 68 | REVISION | | | |
| 69 | REVISION | | | |
| 70 | REVISION | | | |
| 71 | REVISION | | | |
| 72 | REVISION | | | |
| 73 | REVISION | | | |
| 74 | REVISION | | | |
| 75 | REVISION | | | |
| 76 | REVISION | | | |
| 77 | REVISION | | | |
| 78 | REVISION | | | |
| 79 | REVISION | | | |
| 80 | REVISION | | | |
| 81 | REVISION | | | |
| 82 | REVISION | | | |
| 83 | REVISION | | | |
| 84 | REVISION | | | |
| 85 | REVISION | | | |
| 86 | REVISION | | | |
| 87 | REVISION | | | |
| 88 | REVISION | | | |
| 89 | REVISION | | | |
| 90 | REVISION | | | |
| 91 | REVISION | | | |
| 92 | REVISION | | | |
| 93 | REVISION | | | |
| 94 | REVISION | | | |
| 95 | REVISION | | | |
| 96 | REVISION | | | |
| 97 | REVISION | | | |
| 98 | REVISION | | | |
| 99 | REVISION | | | |
| 100 | REVISION | | | |

FSV CUSTOM FIRE CHASSIS
US COMMUNITIES
D :24 15989 A.1

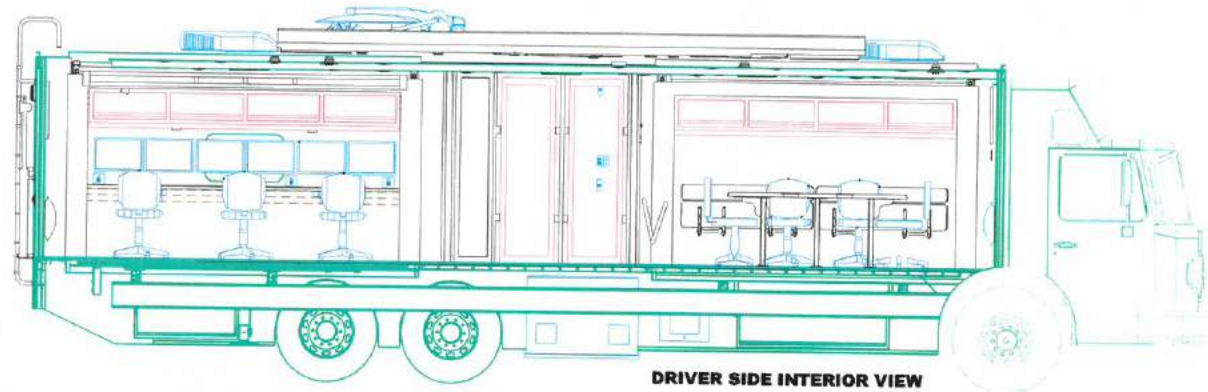

DRIVER SIDE INTERIOR VIEW

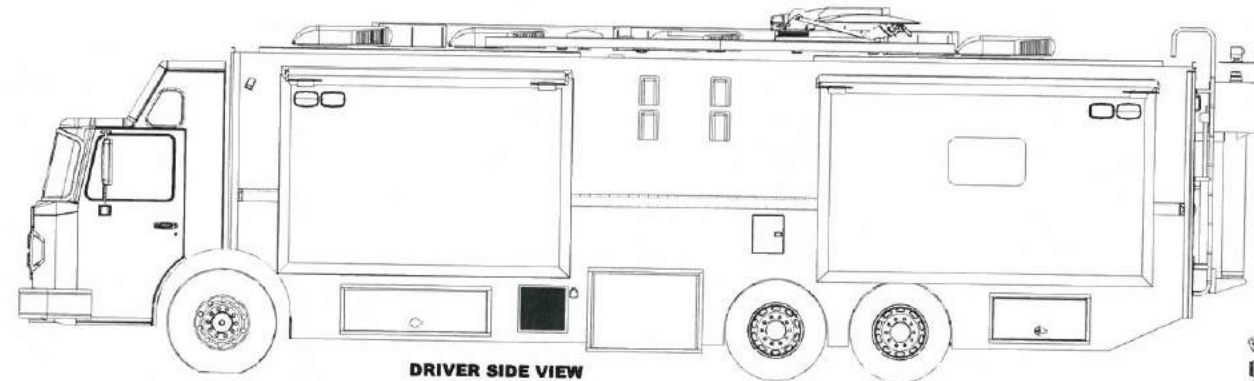

DRIVER SIDE VIEW

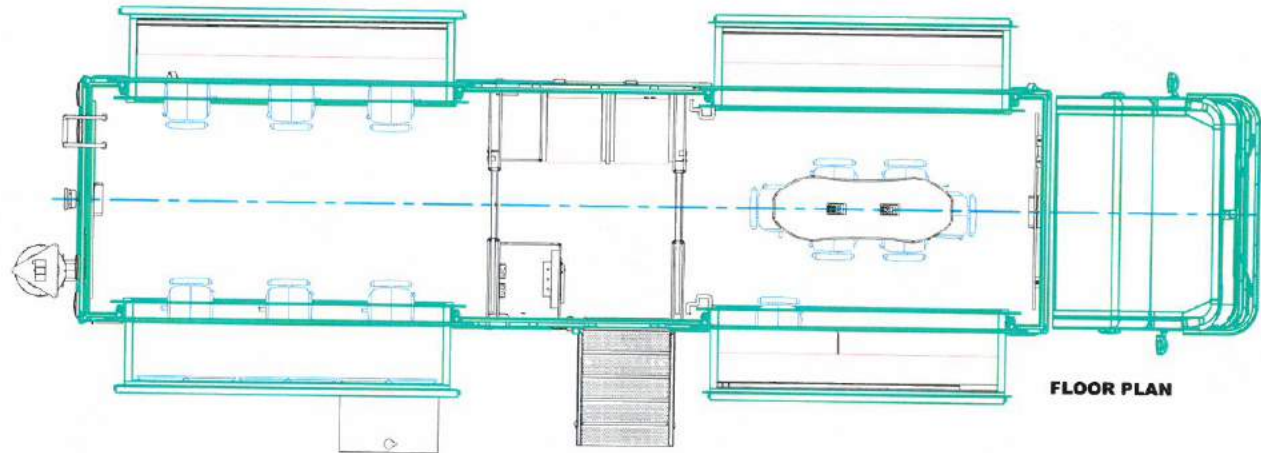

FLOOR PLAN

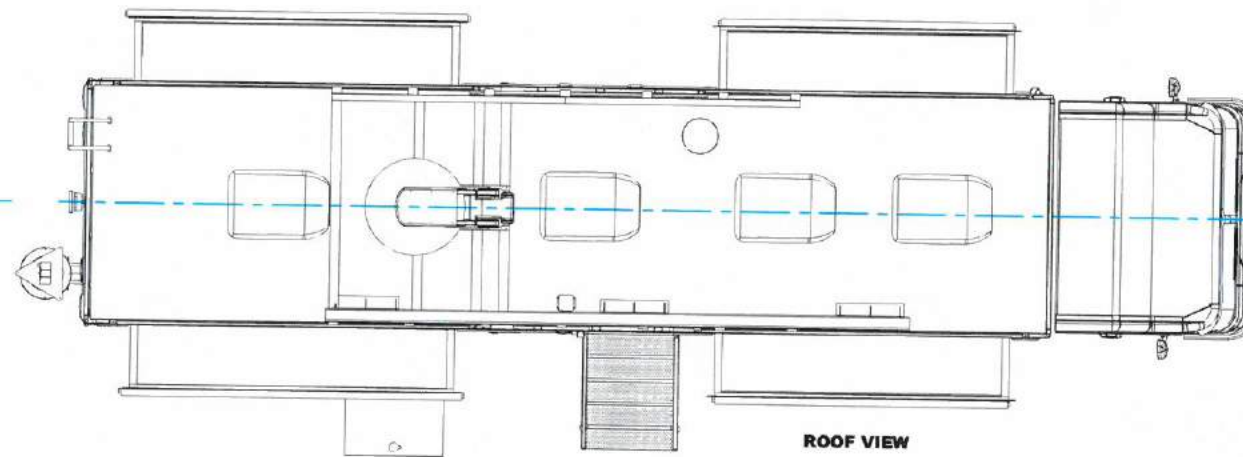

ROOF VIEW

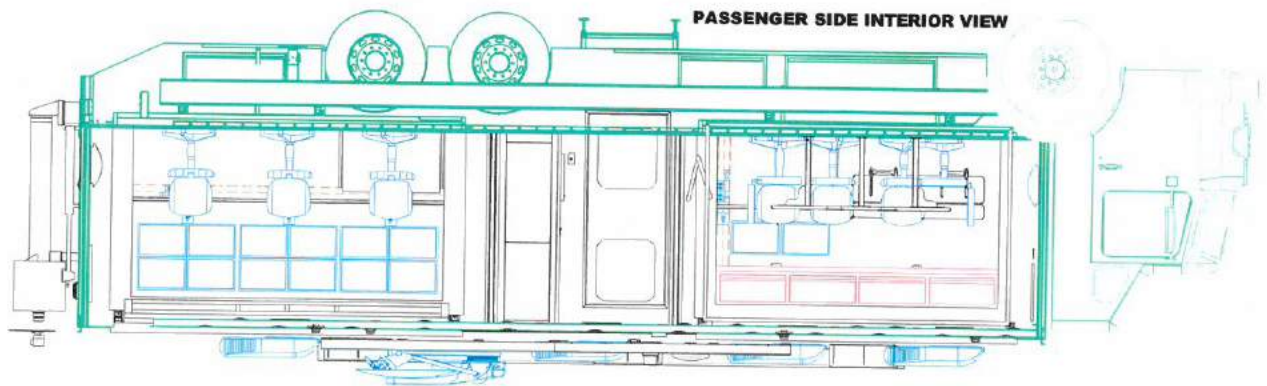
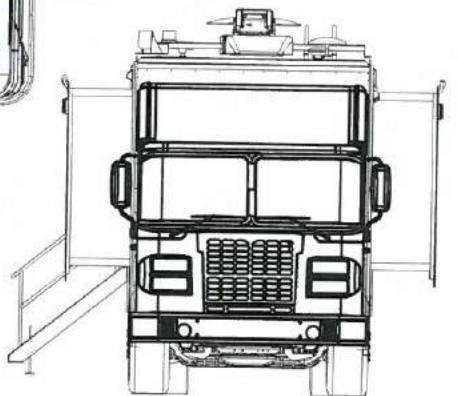
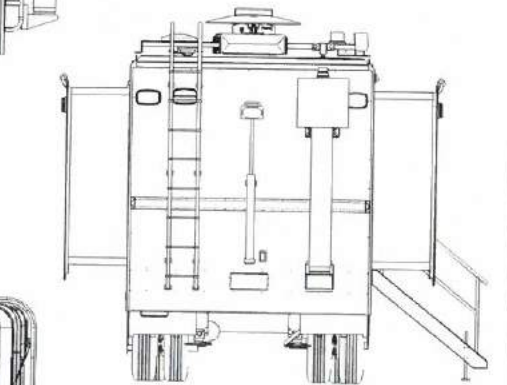

PASSENGER SIDE INTERIOR VIEW



PASSENGER SIDE VIEW

FARBER
SPECIALTY VEHICLES
7052 AMERICANA PARKWAY
COLUMBUS, OH 43068
USA

| | | | | | |
|-----|----------|------|------|-------|-------------|
| REV | DATE | BY | CHKD | APP'D | DESCRIPTION |
| 1 | 11/14/14 | HAAG | DEE | | ISSUE |
| 2 | 11/14/14 | HAAG | DEE | | REVISION |
| 3 | 11/14/14 | HAAG | DEE | | REVISION |
| 4 | 11/14/14 | HAAG | DEE | | REVISION |
| 5 | 11/14/14 | HAAG | DEE | | REVISION |
| 6 | 11/14/14 | HAAG | DEE | | REVISION |
| 7 | 11/14/14 | HAAG | DEE | | REVISION |
| 8 | 11/14/14 | HAAG | DEE | | REVISION |
| 9 | 11/14/14 | HAAG | DEE | | REVISION |
| 10 | 11/14/14 | HAAG | DEE | | REVISION |
| 11 | 11/14/14 | HAAG | DEE | | REVISION |
| 12 | 11/14/14 | HAAG | DEE | | REVISION |
| 13 | 11/14/14 | HAAG | DEE | | REVISION |
| 14 | 11/14/14 | HAAG | DEE | | REVISION |
| 15 | 11/14/14 | HAAG | DEE | | REVISION |
| 16 | 11/14/14 | HAAG | DEE | | REVISION |
| 17 | 11/14/14 | HAAG | DEE | | REVISION |
| 18 | 11/14/14 | HAAG | DEE | | REVISION |
| 19 | 11/14/14 | HAAG | DEE | | REVISION |
| 20 | 11/14/14 | HAAG | DEE | | REVISION |
| 21 | 11/14/14 | HAAG | DEE | | REVISION |
| 22 | 11/14/14 | HAAG | DEE | | REVISION |
| 23 | 11/14/14 | HAAG | DEE | | REVISION |
| 24 | 11/14/14 | HAAG | DEE | | REVISION |
| 25 | 11/14/14 | HAAG | DEE | | REVISION |
| 26 | 11/14/14 | HAAG | DEE | | REVISION |
| 27 | 11/14/14 | HAAG | DEE | | REVISION |
| 28 | 11/14/14 | HAAG | DEE | | REVISION |
| 29 | 11/14/14 | HAAG | DEE | | REVISION |
| 30 | 11/14/14 | HAAG | DEE | | REVISION |
| 31 | 11/14/14 | HAAG | DEE | | REVISION |
| 32 | 11/14/14 | HAAG | DEE | | REVISION |
| 33 | 11/14/14 | HAAG | DEE | | REVISION |
| 34 | 11/14/14 | HAAG | DEE | | REVISION |
| 35 | 11/14/14 | HAAG | DEE | | REVISION |
| 36 | 11/14/14 | HAAG | DEE | | REVISION |
| 37 | 11/14/14 | HAAG | DEE | | REVISION |
| 38 | 11/14/14 | HAAG | DEE | | REVISION |
| 39 | 11/14/14 | HAAG | DEE | | REVISION |
| 40 | 11/14/14 | HAAG | DEE | | REVISION |
| 41 | 11/14/14 | HAAG | DEE | | REVISION |
| 42 | 11/14/14 | HAAG | DEE | | REVISION |
| 43 | 11/14/14 | HAAG | DEE | | REVISION |
| 44 | 11/14/14 | HAAG | DEE | | REVISION |
| 45 | 11/14/14 | HAAG | DEE | | REVISION |
| 46 | 11/14/14 | HAAG | DEE | | REVISION |
| 47 | 11/14/14 | HAAG | DEE | | REVISION |
| 48 | 11/14/14 | HAAG | DEE | | REVISION |
| 49 | 11/14/14 | HAAG | DEE | | REVISION |
| 50 | 11/14/14 | HAAG | DEE | | REVISION |
| 51 | 11/14/14 | HAAG | DEE | | REVISION |
| 52 | 11/14/14 | HAAG | DEE | | REVISION |
| 53 | 11/14/14 | HAAG | DEE | | REVISION |
| 54 | 11/14/14 | HAAG | DEE | | REVISION |
| 55 | 11/14/14 | HAAG | DEE | | REVISION |
| 56 | 11/14/14 | HAAG | DEE | | REVISION |
| 57 | 11/14/14 | HAAG | DEE | | REVISION |
| 58 | 11/14/14 | HAAG | DEE | | REVISION |
| 59 | 11/14/14 | HAAG | DEE | | REVISION |
| 60 | 11/14/14 | HAAG | DEE | | REVISION |
| 61 | 11/14/14 | HAAG | DEE | | REVISION |
| 62 | 11/14/14 | HAAG | DEE | | REVISION |
| 63 | 11/14/14 | HAAG | DEE | | REVISION |
| 64 | 11/14/14 | HAAG | DEE | | REVISION |
| 65 | 11/14/14 | HAAG | DEE | | REVISION |
| 66 | 11/14/14 | HAAG | DEE | | REVISION |
| 67 | 11/14/14 | HAAG | DEE | | REVISION |
| 68 | 11/14/14 | HAAG | DEE | | REVISION |
| 69 | 11/14/14 | HAAG | DEE | | REVISION |
| 70 | 11/14/14 | HAAG | DEE | | REVISION |
| 71 | 11/14/14 | HAAG | DEE | | REVISION |
| 72 | 11/14/14 | HAAG | DEE | | REVISION |
| 73 | 11/14/14 | HAAG | DEE | | REVISION |
| 74 | 11/14/14 | HAAG | DEE | | REVISION |
| 75 | 11/14/14 | HAAG | DEE | | REVISION |
| 76 | 11/14/14 | HAAG | DEE | | REVISION |
| 77 | 11/14/14 | HAAG | DEE | | REVISION |
| 78 | 11/14/14 | HAAG | DEE | | REVISION |
| 79 | 11/14/14 | HAAG | DEE | | REVISION |
| 80 | 11/14/14 | HAAG | DEE | | REVISION |
| 81 | 11/14/14 | HAAG | DEE | | REVISION |
| 82 | 11/14/14 | HAAG | DEE | | REVISION |
| 83 | 11/14/14 | HAAG | DEE | | REVISION |
| 84 | 11/14/14 | HAAG | DEE | | REVISION |
| 85 | 11/14/14 | HAAG | DEE | | REVISION |
| 86 | 11/14/14 | HAAG | DEE | | REVISION |
| 87 | 11/14/14 | HAAG | DEE | | REVISION |
| 88 | 11/14/14 | HAAG | DEE | | REVISION |
| 89 | 11/14/14 | HAAG | DEE | | REVISION |
| 90 | 11/14/14 | HAAG | DEE | | REVISION |
| 91 | 11/14/14 | HAAG | DEE | | REVISION |
| 92 | 11/14/14 | HAAG | DEE | | REVISION |
| 93 | 11/14/14 | HAAG | DEE | | REVISION |
| 94 | 11/14/14 | HAAG | DEE | | REVISION |
| 95 | 11/14/14 | HAAG | DEE | | REVISION |
| 96 | 11/14/14 | HAAG | DEE | | REVISION |
| 97 | 11/14/14 | HAAG | DEE | | REVISION |
| 98 | 11/14/14 | HAAG | DEE | | REVISION |
| 99 | 11/14/14 | HAAG | DEE | | REVISION |
| 100 | 11/14/14 | HAAG | DEE | | REVISION |

FSV CUSTOM FIRE CHASSIS
US COMMUNITIES

D 124 16438 A.1

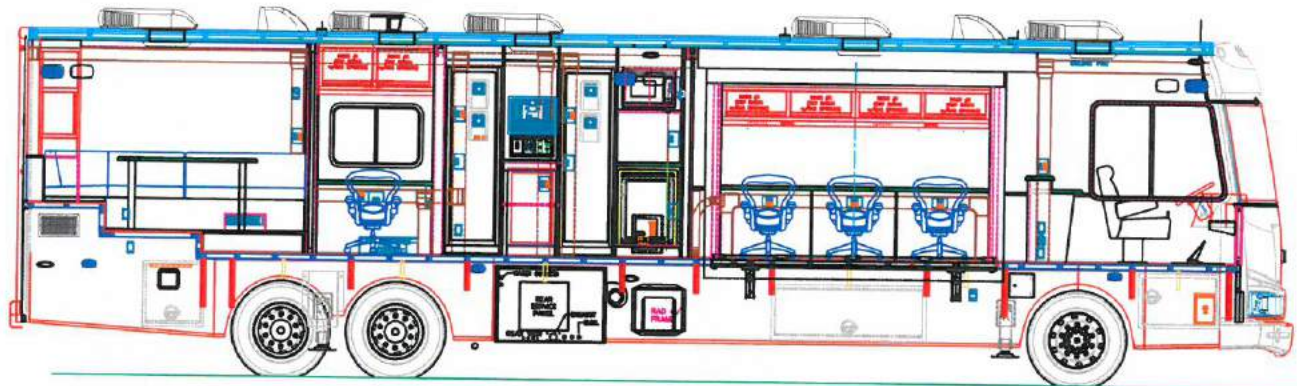

DRIVER SIDE INTERIOR VIEW

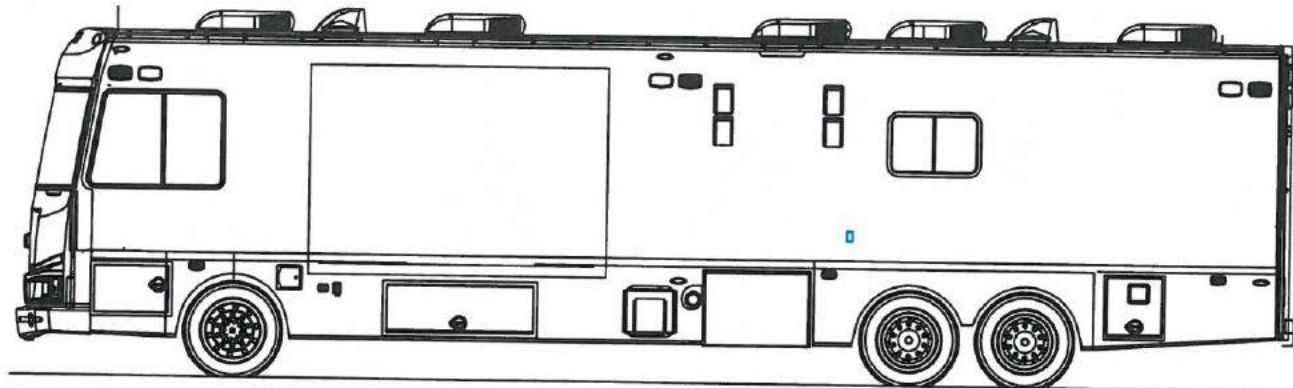

DRIVER SIDE VIEW



FRONT VIEW

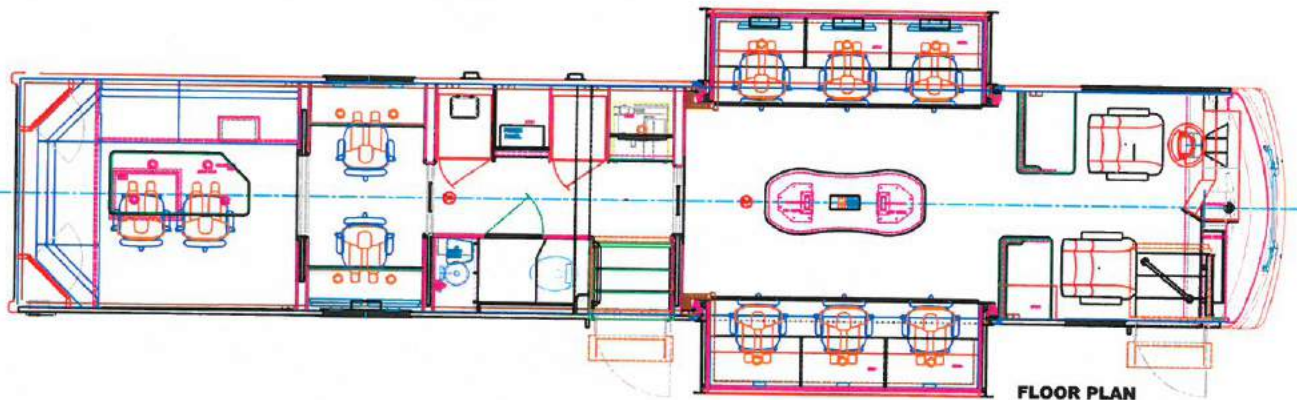

FLOOR PLAN

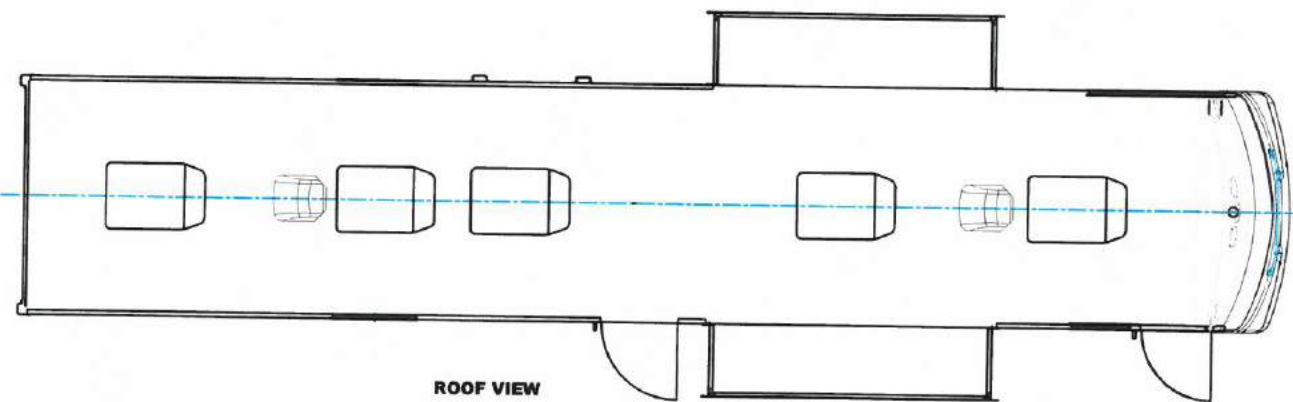

ROOF VIEW

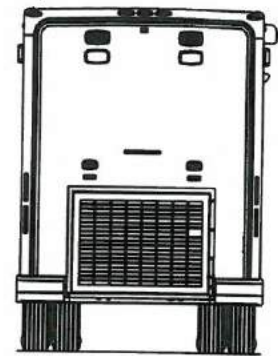

REAR VIEW

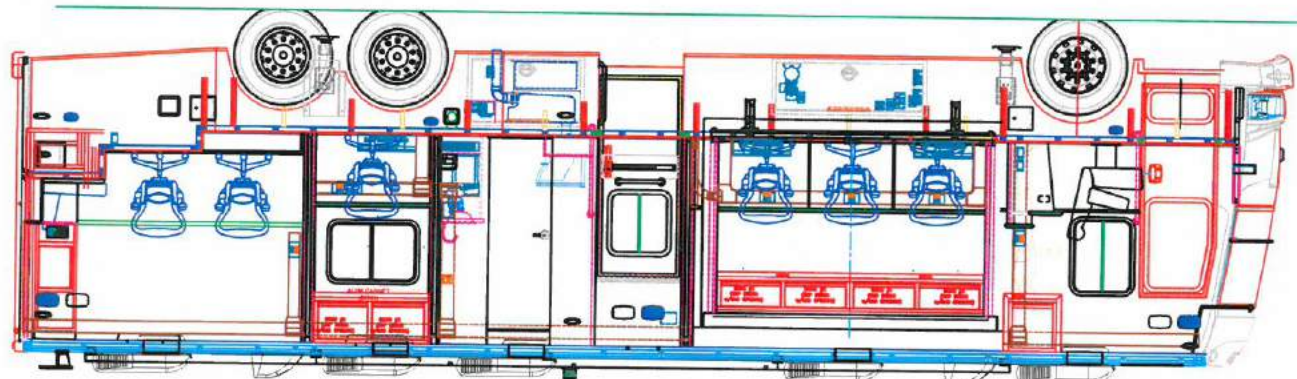

PASSENGER SIDE INTERIOR VIEW

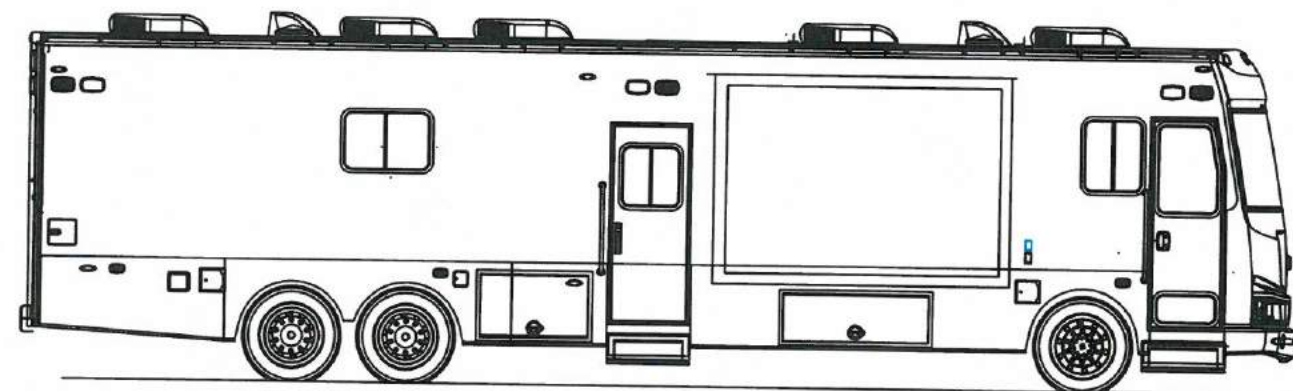

PASSENGER SIDE VIEW

CUSTOMER APPROVAL

PRINT NAME _____
SIGNATURE _____ DATE _____

FARBER
SPECIALTY VEHICLES
795 AMERICANA PARKWAY
COLUMBUS, OH 43068
USA

| | | |
|--------|--|----------------------------|
| REV | DESIGN ENGINEER: GIBBART, INC. 1-16-08 | CUSTOMER: |
| CHANGE | DATE ENGINEER: T. DINDOS DATE WFL APPROVAL: | FSV CUSTOM COACH STYLE 45' |
| | MADE BY: GOODYEAR | TITLE: |
| | PROPRIETARY AND CONFIDENTIAL | US COMMUNITIES |
| | | SHEET NO. E |
| | | SCALE: 1:24 |
| | | UNIT NO. 16225 |
| | | REV. A.5 |

FARBER SPECIALTY VEHICLES, INC.

LIMITED WARRANTY

Thank you for choosing to purchase a FARBER MOBILE UNIT, a fine product in which design and construction have received the care that quality demands. This important warranty covers many items and is indicative of our desire to stand behind our products and assure our customers' complete satisfaction.

WARRANTY COVERAGE:

Farber Specialty Vehicles, 7052 Americana Parkway, Reynoldsburg (Columbus), Ohio 43068 (Warrantor) warrants the original consumer (Purchaser) for a period of (1) one year from date of delivery to the purchaser (Warranty Period), that the interior structure of the vehicle, plumbing, heating, electrical systems, and all appliances and equipment installed by the warrantor, is warranted under normal use to be free of substantial defects in materials and workmanship attributable to Warrantor.

THIS WARRANTY DOES NOT COVER:

1. The automotive system (including the chassis and drive train), tires and batteries, which are covered by the separate warranties of the respective manufacturers of these components.
2. Defects caused by or related to:
 - a. Abuse, misuse, negligence or accident;
 - b. Failure to comply with instructions contained in the owner's manual;
 - c. Alteration or modification of the mobile unit;
 - d. Environmental conditions (salt, hail, chemicals in the atmosphere, etc.)
3. Normal deterioration due to wear or exposure, such as fading of fabrics or drapes, carpet wear, etc.
4. Normal maintenance and service items, such as light bulbs, fuses, wiper blades, lubricants, etc.
5. Transportation to and from dealer or manufacturing plant location, loss of time, inconvenience, commercial loss, loss of use, towing charges.

OWNER'S OBLIGATIONS:

If a problem occurs which the owner believes is covered by this warranty, the owner shall contact the manufacturer by calling the toll free number with sufficient information to resolve the matter. Authorization will be given to repair or replace the defective material.

TWO (2) YEAR LIMITED WARRANTY

Thank you for choosing
FARBER SPECIALTY VEHICLES, INC.

Thank you for choosing to purchase a FARBER MOBILE UNIT, a fine product in which design and construction have received the care that quality demands. This important warranty covers many items and is indicative of our desire to stand behind our products and assure our customers' complete satisfaction.

WARRANTY COVERAGE:

Farber Specialty Vehicles, 7052 Americana Parkway, Reynoldsburg (Columbus), Ohio 43068 (Warrantor) warrants the original consumer (Purchaser) for a period of (2) two years from date of delivery to the purchaser (Warranty Period), that the interior structures of the vehicle, plumbing, heating, electrical systems, and all cabinetry and hardware installed by the warrantor, is warranted under normal use to be free of substantial defects in materials and workmanship attributable to Warrantor.

THIS WARRANTY DOES NOT COVER:

1. The automotive system (including the chassis and drive train), tires and batteries, which are covered by the separate warranties of the respective manufacturers of these components.
2. Any part or component covered by a written warranty issued by its manufacturer. Including but not limited to; auxiliary generator, refrigerator, microwave oven, satellite systems, emergency equipment and lighting.
3. Defects caused by or related to:
 - a. Abuse, misuse, negligence or accident;
 - b. Failure to comply with instructions contained in the owner's manual;
 - c. Alteration or modification of the mobile unit;
 - d. Environmental conditions (salt, hail, chemicals in the atmosphere, etc.)
4. Normal deterioration due to wear or exposure, such as fading of fabrics or drapes, carpet wear, etc.
5. Normal maintenance and service items, such as light bulbs, fuses, wiper blades, lubricants, etc.
6. Transportation to and from dealer or manufacturing plant location, loss of time, inconvenience, commercial loss, loss of use, towing charges.

OWNER'S OBLIGATIONS:

If a problem occurs which the owner believes is covered by this warranty, the owner shall contact the manufacturer by calling the toll free number with sufficient information to resolve the matter. Authorization will be given to repair or replace the defective material.

THREE (3) YEAR LIMITED WARRANTY

Thank you for choosing
FARBER SPECIALTY VEHICLES, INC.

Thank you for choosing to purchase a FARBER MOBILE UNIT, a fine product in which design and construction have received the care that quality demands. This important warranty covers many items and is indicative of our desire to stand behind our products and assure our customers' complete satisfaction.

WARRANTY COVERAGE:

Farber Specialty Vehicles, 7052 Americana Parkway, Reynoldsburg (Columbus), Ohio 43068 (Warrantor) warrants the original consumer (Purchaser) for a period of (3) three years from date of delivery to the purchaser (Warranty Period), that the interior structures of the vehicle, plumbing, heating, electrical systems, and all cabinetry and hardware installed by the warrantor, is warranted under normal use to be free of substantial defects in materials and workmanship attributable to Warrantor.

THIS WARRANTY DOES NOT COVER:

1. The automotive system (including the chassis and drive train), tires and batteries, which are covered by the separate warranties of the respective manufacturers of these components.
2. Defects caused by or related to:
 - a. Abuse, misuse, negligence or accident;
 - b. Failure to comply with instructions contained in the owner's manual;
 - c. Alteration or modification of the mobile unit;
 - d. Environmental conditions (salt, hail, chemicals in the atmosphere, etc.)
3. Normal deterioration due to wear or exposure, such as fading of fabrics or drapes, carpet wear, etc.
4. Normal maintenance and service items, such as light bulbs, fuses, wiper blades, lubricants, etc.
5. Transportation to and from dealer or manufacturing plant location, loss of time, inconvenience, commercial loss, loss of use, towing charges.

OWNER'S OBLIGATIONS:

If a problem occurs which the owner believes is covered by this warranty, the owner shall contact the manufacturer by calling the toll free number with sufficient information to resolve the matter. Authorization will be given to repair or replace the defective material.



Tab 6



Tab 7

11-15-23

EXCEPTIONS FOR CONTRACT

Farber Specialty Vehicles requests the following changes or exceptions be allowed in the contract as proposed:

- 1. Farber reserves the right to sell used units under the contract. Retrofitting and upfitting of used units that are in good shape are a big part of our business and clients like it to be on the contract.***
- 2. Farber reserves the right to expand our upfitting section during the contract negotiation phase with the approval of Henrico County and GOVMVMT.***
- 3. Farber requests that our MSRP pricing contract be presented on December 15th and May 15th, of every year if any updates or additions are needed, for annual effective dates of 1/1 and 6/1 . All price increases will include detailed information and back up.***
- 4. Farber is in current negation with suppliers that would expand their options and product line. Henrico County and GOVMVMT would agree to allow those items, with discount, to be allowed to be added to the Farber Contract with review.***
- 5. Our goal is to have a fluid and up to date offering and not let the length of the contract hinder growth or have to deal with outdated options packages.***



Tab 8



Tab 9

UNITED STATES OF AMERICA
STATE OF OHIO
OFFICE OF THE SECRETARY OF STATE

I, Frank LaRose, do hereby certify that I am the duly elected, qualified and present acting Secretary of State for the State of Ohio, and as such have custody of the records of Ohio and Foreign business entities; that said records show FARBER SPECIALTY VEHICLES, INC., an Ohio corporation, Charter No. 1321655, having its principal location in Columbus, County of Franklin, was incorporated on May 30, 2002 and is currently in GOOD STANDING upon the records of this office.



Witness my hand and the seal of the Secretary of State at Columbus, Ohio this 21st day of November, A.D. 2023.

A handwritten signature in blue ink that reads "Frank LaRose".

Ohio Secretary of State

Validation Number: 202332500956

“Rick Armstrong was amazingly professional and responsive to our needs from the very first query. Your employees are GEMS!”

Shelly Backlar
Friends of the Los Angeles River

| | |
|--|-------------------------|
| Overall Product Functionality: | ✓ Excellent |
| Overall Attention to Detail-Exterior: | ✓ Excellent |
| Overall Attention to Detail-Interior: | ✓ Excellent |
| Product was delivered on time: | ✓ Agree |
| Response to your requirements and concerns: | ✓ Strongly Agree |
| Received everything you ordered/expected: | ✓ Strongly Agree |
| Easy to do business with: | ✓ Strongly Agree |
| Describing and/or training the product: | ✓ Agree |
| Pricing is competitive: | ✓ Strongly Agree |
| Overall quality of your relationship with FSV: | ✓ Excellent |

“Our salesman Rick Armstrong was very interested in our needs and was willing to help in anyway possible to ensure we received a functional and quality product...”

Billy Rhoads

Ft Hood Fire Department

Overall Product Functionality:

✓ **Excellent**

Overall Attention to Detail-Exterior:

✓ **Excellent**

Overall Attention to Detail-Interior:

✓ **Excellent**

Product was delivered on time:

✓ **Strongly Agree**

Response to your requirements and concerns:

✓ **Strongly Agree**

Received everything you ordered/expected:

✓ **Strongly Agree**

Easy to do business with:

✓ **Strongly Agree**

Describing and/or training the product:

✓ **Strongly Agree**

Pricing is competitive:

✓ **Strongly Agree**

Overall quality of your relationship with FSV:

✓ **Excellent**

“Staff was very knowledgeable and helped guide us through the design phase to ensure functionality and ease of use of our required components.”

Colonel Steve Gerould

New York State Environmental Conservation Police

Overall Product Functionality:

✓ **Excellent**

Overall Attention to Detail-Exterior:

✓ **Excellent**

Overall Attention to Detail-Interior:

✓ **Excellent**

Product was delivered on time:

✓ **Strongly Agree**

Response to your requirements and concerns:

✓ **Strongly Agree**

Received everything you ordered/expected:

✓ **Agree**

Easy to do business with:

✓ **Strongly Agree**

Describing and/or training the product:

✓ **Strongly Agree**

Pricing is competitive:

✓ **Strongly Agree**

Overall quality of your relationship with FSV:

✓ **Excellent**

“The company desire to satisfy the customer was very evident.”

Timothy L. Fischer
New York State Police

- | | |
|--|-------------------------|
| Overall Product Functionality: | ✓ Excellent |
| Overall Attention to Detail-Exterior: | ✓ Excellent |
| Overall Attention to Detail-Interior: | ✓ Excellent |
| Product was delivered on time: | ✓ Strongly Agree |
| Response to your requirements and concerns: | ✓ Strongly Agree |
| Received everything you ordered/expected: | ✓ Strongly Agree |
| Easy to do business with: | ✓ Strongly Agree |
| Describing and/or training the product: | ✓ Strongly Agree |
| Pricing is competitive: | ✓ Strongly Agree |
| Overall quality of your relationship with FSV: | ✓ Excellent |

“The time frame was very tight yet FSV came through... exceptionally thorough. FSV did a superb job. Their radio and antenna work was exceptional. FSV is an impressive company.”

Major Donn Herindeen
University of CT Police Department

- | | |
|--|-------------------------|
| Overall Product Functionality: | ✓ Excellent |
| Overall Attention to Detail-Exterior: | ✓ Excellent |
| Overall Attention to Detail-Interior: | ✓ Excellent |
| Product was delivered on time: | ✓ Strongly Agree |
| Response to your requirements and concerns: | ✓ Strongly Agree |
| Received everything you ordered/expected: | ✓ Strongly Agree |
| Easy to do business with: | ✓ Strongly Agree |
| Describing and/or training the product: | ✓ Strongly Agree |
| Pricing is competitive: | ✓ Strongly Agree |
| Overall quality of your relationship with FSV: | ✓ Excellent |

“Farber was able to complete and deliver a quality vehicle in a very tight time frame. Steve Goodyear listened to our needs and handled all we have asked for.”

David Houghton
Department of Fire Service

- | | |
|--|-------------------------|
| Overall Product Functionality: | ✓ Excellent |
| Overall Attention to Detail-Exterior: | ✓ Very Good |
| Overall Attention to Detail-Interior: | ✓ Very Good |
| Product was delivered on time: | ✓ Strongly Agree |
| Response to your requirements and concerns: | ✓ Strongly Agree |
| Received everything you ordered/expected: | ✓ Strongly Agree |
| Easy to do business with: | ✓ Strongly Agree |
| Describing and/or training the product: | ✓ Strongly Agree |
| Pricing is competitive: | ✓ Agree |
| Overall quality of your relationship with FSV: | ✓ Excellent |

“Enjoyed customer service received from the time of the bid to the time I took delivery. Excellent product, service and price.”

William J. Goggins
Vermont Department of Liquor Control

- | | |
|--|-------------------------|
| Overall Product Functionality: | ✓ Excellent |
| Overall Attention to Detail-Exterior: | ✓ Excellent |
| Overall Attention to Detail-Interior: | ✓ Excellent |
| Product was delivered on time: | ✓ Strongly Agree |
| Response to your requirements and concerns: | ✓ Strongly Agree |
| Received everything you ordered/expected: | ✓ Strongly Agree |
| Easy to do business with: | ✓ Strongly Agree |
| Describing and/or training the product: | ✓ Strongly Agree |
| Pricing is competitive: | ✓ Strongly Agree |
| Overall quality of your relationship with FSV: | ✓ Excellent |

**“Enjoyed working with the Farber team members.
You will be receiving a letter thanking you for
your great work and patriotism.”**

Mel Potts
NASA

| | |
|--|-------------------------|
| Overall Product Functionality: | ✓ Excellent |
| Overall Attention to Detail-Exterior: | ✓ Excellent |
| Overall Attention to Detail-Interior: | ✓ Excellent |
| Product was delivered on time: | ✓ Strongly Agree |
| Response to your requirements and concerns: | ✓ Strongly Agree |
| Received everything you ordered/expected: | ✓ Strongly Agree |
| Easy to do business with: | ✓ Strongly Agree |
| Describing and/or training the product: | ✓ N/A |
| Pricing is competitive: | ✓ Strongly Agree |
| Overall quality of your relationship with FSV: | ✓ Excellent |

“All of your staff was friendly and went the extra mile to ensure our satisfaction”

Jay Eppel
City of Carlsbad

- | | |
|--|-------------------------|
| Overall Product Functionality: | ✓ Excellent |
| Overall Attention to Detail-Exterior: | ✓ Excellent |
| Overall Attention to Detail-Interior: | ✓ Excellent |
| Product was delivered on time: | ✓ Strongly Agree |
| Response to your requirements and concerns: | ✓ Strongly Agree |
| Received everything you ordered/expected: | ✓ Strongly Agree |
| Easy to do business with: | ✓ Strongly Agree |
| Describing and/or training the product: | ✓ Strongly Agree |
| Pricing is competitive: | ✓ Strongly Agree |
| Overall quality of your relationship with FSV: | ✓ Excellent |

“I thought being able to work with the owner of the company on a personal level was a strong point of our relationship.”

John Asher

State of Indiana/IPSC

Overall Product Functionality:

✓ **Excellent**

Overall Attention to Detail-Exterior:

✓ **Excellent**

Overall Attention to Detail-Interior:

✓ **Excellent**

Product was delivered on time:

✓ **Strongly Agree**

Response to your requirements and concerns:

✓ **Strongly Agree**

Received everything you ordered/expected:

✓ **Strongly Agree**

Easy to do business with:

✓ **Strongly Agree**

Describing and/or training the product:

✓ **Agree**

Pricing is competitive:

✓ **Agree**

Overall quality of your relationship with FSV:

✓ **Excellent**

“Your salesman Bruce Potter went over the top to assist me in designing the vehicle. He helped me maximize the capabilities and ensure the vehicle could be upgraded for future use.”

Jason Millett

Dugway Proving Ground

Overall Product Functionality:

✓ **Excellent**

Overall Attention to Detail-Exterior:

✓ **Very Good**

Overall Attention to Detail-Interior:

✓ **Very Good**

Product was delivered on time:

✓ **Strongly Agree**

Response to your requirements and concerns:

✓ **Strongly Agree**

Received everything you ordered/expected:

✓ **Agree**

Easy to do business with:

✓ **Strongly Agree**

Describing and/or training the product:

✓ **Strongly Agree**

Pricing is competitive:

✓ **Strongly Agree**

Overall quality of your relationship with FSV:

✓ **Excellent**

“The companys desire to satisfy the customer was very evident...we are 100% satisfied! Thanks to Steve Goodyear and all the staff!”

Timothy L. Fischer
New York State Police

- | | |
|--|-------------------------|
| Overall Product Functionality: | ✓ Excellent |
| Overall Attention to Detail-Exterior: | ✓ Excellent |
| Overall Attention to Detail-Interior: | ✓ Excellent |
| Product was delivered on time: | ✓ Strongly Agree |
| Response to your requirements and concerns: | ✓ Strongly Agree |
| Received everything you ordered/expected: | ✓ Strongly Agree |
| Easy to do business with: | ✓ Strongly Agree |
| Describing and/or training the product: | ✓ Strongly Agree |
| Pricing is competitive: | ✓ Strongly Agree |
| Overall quality of your relationship with FSV: | ✓ Excellent |

“Very impressed with the positive attitude expressed by all we had contact with. All experiences with staff were pleasant and professional.”

Larry W. Shifflett
Harrisonburg Fire Department

| | |
|--|-------------------------|
| Overall Product Functionality: | ✓ Excellent |
| Overall Attention to Detail-Exterior: | ✓ Excellent |
| Overall Attention to Detail-Interior: | ✓ Excellent |
| Product was delivered on time: | ✓ Agree |
| Response to your requirements and concerns: | ✓ Strongly Agree |
| Received everything you ordered/expected: | ✓ Strongly Agree |
| Easy to do business with: | ✓ Strongly Agree |
| Describing and/or training the product: | ✓ Strongly Agree |
| Pricing is competitive: | ✓ Strongly Agree |
| Overall quality of your relationship with FSV: | ✓ Excellent |

“It was wonderful to work with a professional business who cares about the customer! We would do a Farber vehicle again and highly recommend them to anyone who asks.”

Dave Todd
SCCMO

| | |
|--|-------------------------|
| Overall Product Functionality: | ✓ Excellent |
| Overall Attention to Detail-Exterior: | ✓ Excellent |
| Overall Attention to Detail-Interior: | ✓ Excellent |
| Product was delivered on time: | ✓ Strongly Agree |
| Response to your requirements and concerns: | ✓ Strongly Agree |
| Received everything you ordered/expected: | ✓ Strongly Agree |
| Easy to do business with: | ✓ Strongly Agree |
| Describing and/or training the product: | ✓ Strongly Agree |
| Pricing is competitive: | ✓ Strongly Agree |
| Overall quality of your relationship with FSV: | ✓ Excellent |

“I am extremely satisfied and would recommend FSV to anybody if you want a quality product and a quality TEAM. We will be calling back to work on our regional command trailer.”

Jack VanZile
Chautauqua County Sheriff's Office

- | | |
|--|-------------------------|
| Overall Product Functionality: | ✓ Excellent |
| Overall Attention to Detail-Exterior: | ✓ Excellent |
| Overall Attention to Detail-Interior: | ✓ Excellent |
| Product was delivered on time: | ✓ Strongly Agree |
| Response to your requirements and concerns: | ✓ Strongly Agree |
| Received everything you ordered/expected: | ✓ Strongly Agree |
| Easy to do business with: | ✓ Strongly Agree |
| Describing and/or training the product: | ✓ Strongly Agree |
| Pricing is competitive: | ✓ Strongly Agree |
| Overall quality of your relationship with FSV: | ✓ Excellent |

“Enjoyed the personal attention we received at all stages dealing with Farber. Dave Chapman is an outstanding representative for your company”

Jim Stowell
Cayuga County

- | | |
|--|-------------------------|
| Overall Product Functionality: | ✓ Excellent |
| Overall Attention to Detail-Exterior: | ✓ Excellent |
| Overall Attention to Detail-Interior: | ✓ Excellent |
| Product was delivered on time: | ✓ Strongly Agree |
| Response to your requirements and concerns: | ✓ Strongly Agree |
| Received everything you ordered/expected: | ✓ Strongly Agree |
| Easy to do business with: | ✓ Strongly Agree |
| Describing and/or training the product: | ✓ Strongly Agree |
| Pricing is competitive: | ✓ Strongly Agree |
| Overall quality of your relationship with FSV: | ✓ Excellent |

**“You do more than you are asked to do!
And deliver more than we required!”**

Tucker Viemeister
Rockwell Group

| | |
|--|-------------------------|
| Overall Product Functionality: | ✓ Excellent |
| Overall Attention to Detail-Exterior: | ✓ Excellent |
| Overall Attention to Detail-Interior: | ✓ Excellent |
| Product was delivered on time: | ✓ Strongly Agree |
| Response to your requirements and concerns: | ✓ Strongly Agree |
| Received everything you ordered/expected: | ✓ Strongly Agree |
| Easy to do business with: | ✓ Strongly Agree |
| Describing and/or training the product: | ✓ Strongly Agree |
| Pricing is competitive: | ✓ Strongly Agree |
| Overall quality of your relationship with FSV: | ✓ Excellent |

“The personal involvement from the entire team was excellent, and created a great environment to work in. It felt like a very collaborative process”

Liz McMullan
Jamie Oliver

| | |
|--|-------------------------|
| Overall Product Functionality: | ✓ Excellent |
| Overall Attention to Detail-Exterior: | ✓ Excellent |
| Overall Attention to Detail-Interior: | ✓ Excellent |
| Product was delivered on time: | ✓ Strongly Agree |
| Response to your requirements and concerns: | ✓ Strongly Agree |
| Received everything you ordered/expected: | ✓ Strongly Agree |
| Easy to do business with: | ✓ Strongly Agree |
| Describing and/or training the product: | ✓ N/A |
| Pricing is competitive: | ✓ N/A |
| Overall quality of your relationship with FSV: | ✓ Excellent |

“The professionalism and patience displayed by the Farber team throughout the entire planning and purchasing phase. Working with the Farber staff was an enjoyable experience.”

Robert Clay
Robins AFB

- | | |
|--|-------------------------|
| Overall Product Functionality: | ✓ Excellent |
| Overall Attention to Detail-Exterior: | ✓ Excellent |
| Overall Attention to Detail-Interior: | ✓ Excellent |
| Product was delivered on time: | ✓ Strongly Agree |
| Response to your requirements and concerns: | ✓ Strongly Agree |
| Received everything you ordered/expected: | ✓ Strongly Agree |
| Easy to do business with: | ✓ Strongly Agree |
| Describing and/or training the product: | ✓ Strongly Agree |
| Pricing is competitive: | ✓ Strongly Agree |
| Overall quality of your relationship with FSV: | ✓ Excellent |

“Dave Chapman was easy to work with, easy to get ahold of and quick responses.”

Jeremy Jensen
Dubuque Police Dept.

| | |
|--|-------------------------|
| Overall Product Functionality: | ✓ Excellent |
| Overall Attention to Detail-Exterior: | ✓ Very Good |
| Overall Attention to Detail-Interior: | ✓ Excellent |
| Product was delivered on time: | ✓ Strongly Agree |
| Response to your requirements and concerns: | ✓ Neutral |
| Received everything you ordered/expected: | ✓ Disagree |
| Easy to do business with: | ✓ Strongly Agree |
| Describing and/or training the product: | ✓ Strongly Agree |
| Pricing is competitive: | ✓ Strongly Agree |
| Overall quality of your relationship with FSV: | ✓ Very Good |

“Cooperation and knowledge Creativity and friendliness.”

Diane Russell
IECC

- | | |
|--|-------------------------|
| Overall Product Functionality: | ✓ Excellent |
| Overall Attention to Detail-Exterior: | ✓ Excellent |
| Overall Attention to Detail-Interior: | ✓ Excellent |
| Product was delivered on time: | ✓ Strongly Agree |
| Response to your requirements and concerns: | ✓ Strongly Agree |
| Received everything you ordered/expected: | ✓ Strongly Agree |
| Easy to do business with: | ✓ Strongly Agree |
| Describing and/or training the product: | ✓ Strongly Agree |
| Pricing is competitive: | ✓ Strongly Agree |
| Overall quality of your relationship with FSV: | ✓ Excellent |

“Rick Armstrong is accessible, personable and responsive.”

E Flowers-Fields
TCCSMD

Overall Product Functionality:

✓ **Very Good**

Overall Attention to Detail-Exterior:

✓ **Excellent**

Overall Attention to Detail-Interior:

✓ **Very Good**

Product was delivered on time:

✓ **Strongly Agree**

Response to your requirements and concerns:

✓ **Strongly Agree**

Received everything you ordered/expected:

✓ **Strongly Agree**

Easy to do business with:

✓ **Strongly Agree**

Describing and/or training the product:

✓ **Strongly Agree**

Pricing is competitive:

✓ **Strongly Agree**

Overall quality of your relationship with FSV:

✓ **Excellent**

“Any public safety agency in the market for a command or specialty vehicle should take a very close look at FSV. Their quality craftsmanship and competitive pricing are hard to beat.”

Lou Vargo
Ohio County EMA

| | |
|--|-------------------------|
| Overall Product Functionality: | ✓ Excellent |
| Overall Attention to Detail-Exterior: | ✓ Excellent |
| Overall Attention to Detail-Interior: | ✓ Excellent |
| Product was delivered on time: | ✓ Strongly Agree |
| Response to your requirements and concerns: | ✓ Strongly Agree |
| Received everything you ordered/expected: | ✓ Strongly Agree |
| Easy to do business with: | ✓ Strongly Agree |
| Describing and/or training the product: | ✓ Strongly Agree |
| Pricing is competitive: | ✓ Strongly Agree |
| Overall quality of your relationship with FSV: | ✓ Excellent |

“Best experience that I’ve had with a vendor in my 29 year law enforcement career”

Captain Dwayne B. Arceneaux
Lafayette Police Department

- | | |
|--|-------------------------|
| Overall Product Functionality: | ✓ Excellent |
| Overall Attention to Detail-Exterior: | ✓ Excellent |
| Overall Attention to Detail-Interior: | ✓ Excellent |
| Product was delivered on time: | ✓ Strongly Agree |
| Response to your requirements and concerns: | ✓ Strongly Agree |
| Received everything you ordered/expected: | ✓ Strongly Agree |
| Easy to do business with: | ✓ Strongly Agree |
| Describing and/or training the product: | ✓ Strongly Agree |
| Pricing is competitive: | ✓ Strongly Agree |
| Overall quality of your relationship with FSV: | ✓ Excellent |

“Farber is an incredible company with amazing employees”

Richard Rees
Lafayette Police Department

| | |
|--|-------------------------|
| Overall Product Functionality: | ✓ Excellent |
| Overall Attention to Detail-Exterior: | ✓ Excellent |
| Overall Attention to Detail-Interior: | ✓ Excellent |
| Product was delivered on time: | ✓ Strongly Agree |
| Response to your requirements and concerns: | ✓ Strongly Agree |
| Received everything you ordered/expected: | ✓ Strongly Agree |
| Easy to do business with: | ✓ Strongly Agree |
| Describing and/or training the product: | ✓ Strongly Agree |
| Pricing is competitive: | ✓ Strongly Agree |
| Overall quality of your relationship with FSV: | ✓ Excellent |

“Enjoyed professionalism of the staff”

Lt. Melvin D. Howard
New Orleans Police Department

- | | |
|--|-------------------------|
| Overall Product Functionality: | ✓ Excellent |
| Overall Attention to Detail-Exterior: | ✓ Excellent |
| Overall Attention to Detail-Interior: | ✓ Excellent |
| Product was delivered on time: | ✓ Agree |
| Response to your requirements and concerns: | ✓ Strongly Agree |
| Received everything you ordered/expected: | ✓ Strongly Agree |
| Easy to do business with: | ✓ Strongly Agree |
| Describing and/or training the product: | ✓ Strongly Agree |
| Pricing is competitive: | ✓ Strongly Agree |
| Overall quality of your relationship with FSV: | ✓ Excellent |

“I am extremely satisfied with my Dental coach and would highly recomend FSV. Donavin made the entire process very easy”

Kelli Johnson
Suncoast

- | | |
|--|-------------------------|
| Overall Product Functionality: | ✓ Excellent |
| Overall Attention to Detail-Exterior: | ✓ Excellent |
| Overall Attention to Detail-Interior: | ✓ Excellent |
| Product was delivered on time: | ✓ Strongly Agree |
| Response to your requirements and concerns: | ✓ Strongly Agree |
| Received everything you ordered/expected: | ✓ Strongly Agree |
| Easy to do business with: | ✓ Strongly Agree |
| Describing and/or training the product: | ✓ Strongly Agree |
| Pricing is competitive: | ✓ Strongly Agree |
| Overall quality of your relationship with FSV: | ✓ Excellent |

“Very personable sales personnel. Very quick response to all questions and concerns, even after delivery”

Laura Medows
IHC Inc.

- | | |
|--|-------------------------|
| Overall Product Functionality: | ✓ Excellent |
| Overall Attention to Detail-Exterior: | ✓ Very Good |
| Overall Attention to Detail-Interior: | ✓ Excellent |
| Product was delivered on time: | ✓ Strongly Agree |
| Response to your requirements and concerns: | ✓ Strongly Agree |
| Received everything you ordered/expected: | ✓ Strongly Agree |
| Easy to do business with: | ✓ Strongly Agree |
| Describing and/or training the product: | ✓ Strongly Agree |
| Pricing is competitive: | ✓ Agree |
| Overall quality of your relationship with FSV: | ✓ Excellent |

“Personalized service. No gimmicks, just pure honesty”

John Day
CHRISTUS Spohn Health Systems

- | | |
|--|-------------------------|
| Overall Product Functionality: | ✓ Excellent |
| Overall Attention to Detail-Exterior: | ✓ Excellent |
| Overall Attention to Detail-Interior: | ✓ Excellent |
| Product was delivered on time: | ✓ Strongly Agree |
| Response to your requirements and concerns: | ✓ Strongly Agree |
| Received everything you ordered/expected: | ✓ Strongly Agree |
| Easy to do business with: | ✓ Strongly Agree |
| Describing and/or training the product: | ✓ Strongly Agree |
| Pricing is competitive: | ✓ Strongly Agree |
| Overall quality of your relationship with FSV: | ✓ Excellent |

**“Looks great, very functional, state of the Art!!
We are very pleased with our vehicle”**

Margie Chavez
CHRISTUS Spohn Health System

| | |
|--|-------------------------|
| Overall Product Functionality: | ✓ Excellent |
| Overall Attention to Detail-Exterior: | ✓ Excellent |
| Overall Attention to Detail-Interior: | ✓ Excellent |
| Product was delivered on time: | ✓ Strongly Agree |
| Response to your requirements and concerns: | ✓ Strongly Agree |
| Received everything you ordered/expected: | ✓ Agree |
| Easy to do business with: | ✓ Strongly Agree |
| Describing and/or training the product: | ✓ Neutral |
| Pricing is competitive: | ✓ Agree |
| Overall quality of your relationship with FSV: | ✓ Very Good |

“The flexibility and creativity involed with talented, experienced staff”

Christine Lightfoot
KC VA Med Center

- | | |
|--|-------------------------|
| Overall Product Functionality: | ✓ Excellent |
| Overall Attention to Detail-Exterior: | ✓ Excellent |
| Overall Attention to Detail-Interior: | ✓ Excellent |
| Product was delivered on time: | ✓ Strongly Agree |
| Response to your requirements and concerns: | ✓ Strongly Agree |
| Received everything you ordered/expected: | ✓ Strongly Agree |
| Easy to do business with: | ✓ Strongly Agree |
| Describing and/or training the product: | ✓ Strongly Agree |
| Pricing is competitive: | ✓ Strongly Agree |
| Overall quality of your relationship with FSV: | ✓ Excellent |

“Your personnel were very friendly, helpful, knowledgeable about our service (law enforcement) and responsive to our calls and email questions”

Richard Mulhall
Newington Police/CRCOG

- | | |
|--|-------------------------|
| Overall Product Functionality: | ✓ Excellent |
| Overall Attention to Detail-Exterior: | ✓ Excellent |
| Overall Attention to Detail-Interior: | ✓ Excellent |
| Product was delivered on time: | ✓ Agree |
| Response to your requirements and concerns: | ✓ Strongly Agree |
| Received everything you ordered/expected: | ✓ Strongly Agree |
| Easy to do business with: | ✓ Strongly Agree |
| Describing and/or training the product: | ✓ Strongly Agree |
| Pricing is competitive: | ✓ Agree |
| Overall quality of your relationship with FSV: | ✓ Excellent |

“Quick followup and level of detail provided during delivery and training.”

Samantha Kirby
Saint Thomas Health

- Overall Product Functionality: ✓ **Excellent**
- Overall Attention to Detail-Exterior: ✓ **Excellent**
- Overall Attention to Detail-Interior: ✓ **Excellent**
- Product was delivered on time: ✓ **Strongly Agree**
- Response to your requirements and concerns: ✓ **Strongly Agree**
- Received everything you ordered/expected: ✓ **Strongly Agree**
- Easy to do business with: ✓ **Strongly Agree**
- Describing and/or training the product: ✓ **Strongly Agree**
- Pricing is competitive: ✓ **Strongly Agree**
- Overall quality of your relationship with FSV: ✓ **Excellent**

“David Chapman’s suggestions improved our design concepts and the quality of the vehicle. Very impressed with the management by Farber supported by the tenure of their employees.”

John Morrow
Arkansas State Police

- | | |
|--|-------------------------|
| Overall Product Functionality: | ✓ Excellent |
| Overall Attention to Detail-Exterior: | ✓ Excellent |
| Overall Attention to Detail-Interior: | ✓ Excellent |
| Product was delivered on time: | ✓ Strongly Agree |
| Response to your requirements and concerns: | ✓ Strongly Agree |
| Received everything you ordered/expected: | ✓ Strongly Agree |
| Easy to do business with: | ✓ Strongly Agree |
| Describing and/or training the product: | ✓ Strongly Agree |
| Pricing is competitive: | ✓ Strongly Agree |
| Overall quality of your relationship with FSV: | ✓ Excellent |

“It was extremely helpful working with a fellow law enforcement officer. David Chapman could answer the ‘cop’ questions and knew what we were talking about and what we were thinking”

Chris Simmons

Utah Department of Public Safety

Overall Product Functionality:

✓ **Excellent**

Overall Attention to Detail-Exterior:

✓ **Excellent**

Overall Attention to Detail-Interior:

✓ **Very Good**

Product was delivered on time:

✓ **Agree**

Response to your requirements and concerns:

✓ **Strongly Agree**

Received everything you ordered/expected:

✓ **Strongly Agree**

Easy to do business with:

✓ **Strongly Agree**

Describing and/or training the product:

✓ **Strongly Agree**

Pricing is competitive:

✓ **Strongly Agree**

Overall quality of your relationship with FSV:

✓ **Very Good**

“David Chapman was very responsive and always ensured that we were receiving what we were requesting. Employees were always responsive when I called and had a question”

Roger E. Triplett
Redstone Arsenal PD

| | |
|--|-------------------------|
| Overall Product Functionality: | ✓ Excellent |
| Overall Attention to Detail-Exterior: | ✓ Excellent |
| Overall Attention to Detail-Interior: | ✓ Excellent |
| Product was delivered on time: | ✓ Strongly Agree |
| Response to your requirements and concerns: | ✓ Strongly Agree |
| Received everything you ordered/expected: | ✓ Strongly Agree |
| Easy to do business with: | ✓ Strongly Agree |
| Describing and/or training the product: | ✓ Strongly Agree |
| Pricing is competitive: | ✓ Strongly Agree |
| Overall quality of your relationship with FSV: | ✓ Excellent |

“David Chapman is personable, knowledgeable about the product line and with his police experience he brings a special touch as he understands exactly what are concerns were throughout the process”

Charles Bailey
Alexandria Police CSI

| | |
|--|-------------------------|
| Overall Product Functionality: | ✓ Excellent |
| Overall Attention to Detail-Exterior: | ✓ Excellent |
| Overall Attention to Detail-Interior: | ✓ Excellent |
| Product was delivered on time: | ✓ Strongly Agree |
| Response to your requirements and concerns: | ✓ Strongly Agree |
| Received everything you ordered/expected: | ✓ Strongly Agree |
| Easy to do business with: | ✓ Strongly Agree |
| Describing and/or training the product: | ✓ Strongly Agree |
| Pricing is competitive: | ✓ Strongly Agree |
| Overall quality of your relationship with FSV: | ✓ Excellent |