

REQUEST FOR LEGISLATIVE ACTION



Completed by County Counselor's Office:

~~Res~~/Ord No.: 4914

Sponsor(s): Dennis Waits

Date: October 17, 2016

<p>SUBJECT</p>	<p>Action Requested <input type="checkbox"/> Resolution <input checked="" type="checkbox"/> Ordinance</p> <p>Project/Title: <u>Appropriation of Funds from the 2016 Undesignated Fund Balance to Special Obligation Bond C/P Account 58020 (Building Improvement Account)</u></p>														
<p>BUDGET INFORMATION <i>To be completed By Requesting Department and Finance</i></p>	<table border="1" data-bbox="310 552 1195 1052"> <tr> <td>Amount authorized by this legislation this fiscal year:</td> <td>\$51,768.82</td> </tr> <tr> <td>Amount previously authorized this fiscal year:</td> <td>\$</td> </tr> <tr> <td>Total amount authorized after this legislative action:</td> <td>\$51,768.82</td> </tr> <tr> <td>Amount budgeted for this item * (including transfers):</td> <td>\$</td> </tr> <tr> <td>Source of funding (name of fund) and account code number; FROM / TO</td> <td>FROM ACCT 014 Account 32810 \$51,768.82</td> </tr> <tr> <td>FROM 014-32810 Undesignated Fund Balance Special Obligation Bond Capital Project Fund</td> <td>TO ACCT Fund Account 58020 \$51,768.82</td> </tr> <tr> <td>TO 014-1522-58020 Special Obligation Bond Capital Project Fund Buildings and Improvements</td> <td></td> </tr> </table> <p>* If account includes additional funds for other expenses, total budgeted in the account is: \$</p> <p>OTHER FINANCIAL INFORMATION:</p> <p><input type="checkbox"/> No budget impact (no fiscal note required) <input type="checkbox"/> Term and Supply Contract (funds approved in the annual budget); estimated value and use of contract: Department: Estimated Use: \$</p> <p>Prior Year Budget (if applicable): Prior Year Actual Amount Spent (if applicable):</p>	Amount authorized by this legislation this fiscal year:	\$51,768.82	Amount previously authorized this fiscal year:	\$	Total amount authorized after this legislative action:	\$51,768.82	Amount budgeted for this item * (including transfers):	\$	Source of funding (name of fund) and account code number; FROM / TO	FROM ACCT 014 Account 32810 \$51,768.82	FROM 014-32810 Undesignated Fund Balance Special Obligation Bond Capital Project Fund	TO ACCT Fund Account 58020 \$51,768.82	TO 014-1522-58020 Special Obligation Bond Capital Project Fund Buildings and Improvements	
Amount authorized by this legislation this fiscal year:	\$51,768.82														
Amount previously authorized this fiscal year:	\$														
Total amount authorized after this legislative action:	\$51,768.82														
Amount budgeted for this item * (including transfers):	\$														
Source of funding (name of fund) and account code number; FROM / TO	FROM ACCT 014 Account 32810 \$51,768.82														
FROM 014-32810 Undesignated Fund Balance Special Obligation Bond Capital Project Fund	TO ACCT Fund Account 58020 \$51,768.82														
TO 014-1522-58020 Special Obligation Bond Capital Project Fund Buildings and Improvements															
<p>PRIOR LEGISLATION</p>	<p>Prior ordinances and (date): Ordinances 4187 (1/25/10), 4222 (8/2/10)</p> <p>Prior resolutions and (date):</p>														
<p>CONTACT INFORMATION</p>	<p>RLA drafted by (name, title, & phone): Joseph Tomlinson, Facilities Management Administrator, 881-3748</p>														
<p>REQUEST SUMMARY</p>	<p>Transfer of remainder of Bond Proceed funds for the Great Plains SPCA Animal Shelter to the Building Improvement Account listed above to be used for building improvement tasks, to include surgical tables, canine play yard canopies, surgical lights, and electronic surgical faucets. These tasks will be done through Term and Supply contracts. These items and prices are listed as attachments to this RLA.</p>														

CLEARANCE	<input type="checkbox"/> Tax Clearance Completed (Purchasing & Department) <input type="checkbox"/> Business License Verified (Purchasing & Department) <input type="checkbox"/> Chapter 6 Compliance - Affirmative Action/Prevailing Wage (County Auditor's Office)	
ATTACHMENTS	1. Proposal to construct and install two (2) outdoor canopies for canine play yards. 2. Proposal to provide two (2) surgical steel countertops and one (1) shelf for the Shelter's surgical center. 3. Proposal to provide two (2) LED Medical Illumination Lights for the Shelter's surgical center. 4. Proposal to provide two (2) electronic Medical Faucets for the Shelter's surgical center.	
REVIEW	Department Director: 	Date: 10.6.2016
	Finance (Budget Approval): <i>If applicable</i> 	Date: 10/6/16
	Division Manager: <i>Marylou Brown</i>	Date: 10/13/16
	County Counselor's Office:	Date:

Fiscal Information (to be verified by Budget Office in Finance Department)

- This expenditure was included in the annual budget.
- Funds for this were encumbered from the _____ Fund in ____.
- There is a balance otherwise unencumbered to the credit of the appropriation to which the expenditure is chargeable and there is a cash balance otherwise unencumbered in the treasury to the credit of the fund from which payment is to be made each sufficient to provide for the obligation herein authorized.
- Funds sufficient for this expenditure will be/were appropriated by Ordinance #
- Funds sufficient for this appropriation are available from the source indicated below.

Account Number:	Account Title:	Amount Not to Exceed:
014-2810	Special Obligation Bond Capital Project Fund	\$51,768.82

- This award is made on a need basis and does not obligate Jackson County to pay any specific amount. The availability of funds for specific purchases will, of necessity, be determined as each using agency places its order.
- This legislative action does not impact the County financially and does not require Finance/Budget approval.

Architectural / Commercial / Design / Engineering / Fabrication / Industrial / Installation

STANDARD SHEET METAL

405 NORTH OLIVE STREET
KANSAS CITY, MO 64120

office: 816.221.5434

fax: 816.221.8022

WWW.STANDARDSHEETMETAL.COM



Date 5/24/2016

Customer: George Jonas

Reference: S.S. counter tops

Attention : George

SCOPE: Fabrication of the following.

- One Counter top 16 foot long and 25" Deep with welded sink per existing counter. Material will be 18 ga.
- One Counter top 8-foot-long and 24" Deep with welded sink per existing counter. Material will be 18 ga.
- One 24" x 24" Shelf with wall mounting tabs. All side formed down for strength. Material will be 1/8" Stainless Steel.

CLARIFICATIONS: ALL Material will be 304L with 2B finish. Wood will be 3/4" plywood.

Exclusions: Install of any kind.

PRICING: \$6,872.00

Deduct \$ 1,876.00 For no sink just hole.

Lead time: 3 weeks

Bid good for 30 days

26244



SPRINKLE CEILING
XLDE-SC

[Click here to enlarge](#)

Your Price: \$1,979.00

Product Description:

Medical Illumination MI 500 LED Exam/Diagnostic Single Ceiling Light: XLDE-SC. The MI 500 light is part of the "cutting-edge" MI LED SERIES by Medical Illumination International. EFFICIENT: The MI 500's LED life averages 50,000 hours. It uses significantly less electric consumption than standard halogen lights. COOL.

The MI 500 LED Features: The Light beam and head emit very low heat and are part of our LED solution. BRIGHT - The MI 500 light is output rated at 40,000 lux (3,700 foot candles) at a distance of 24". It is whiter, a more color-correct light. COMPACT - Its 6" diameter head design is small but powerful and has great arm articulation. VERSATILE - Comes with a variety of mounting options, wall mount, portable, single and dual ceiling mounts, and ceiling track mounting. CONVENIENT - Available with optional sterilizable handle. See below for more information.

- [Features](#)
 - [Specifications](#)
 - [Brochure](#)
 - [Options](#)
- LED life averages 50,000 hours
 - MI 500's light beam and head emit very low heat
 - Light is output rated at 40,000 lux (3,700 foot candles) at a distance of 24"
 - Whiter, a more color-correct light
 - Its 6" diameter head design is small but powerful and has great arm articulation
 - Comes with a variety of Mounting Options, wall mount, portable, single and dual ceiling mounts, and ceiling track mounting
 - Available with optional sterilizable handle

Camán Construction Company Inc.

5004 Brighton Ave. Kansas City MO 64132

PHONE: 816-471-0410 FAX: 816-472-8401

Date: 7/12/16

Joe Tomlinson
Jackson County Courthouse
415 E. 12th Street, Room G8
Kansas City, Missouri 64106

Project: **Jackson Animal Shelter Canopies.**

PROPOSAL

This letter serves as a summary of the scope of for the above referenced project:

INCLUSIONS AND CLARIFICATIONS :Install Two 20' x 12'canopies at the dog shelter independence, it will be galvanized only, as per sketch previous submitted.

EXCLUSIONS: 1) Paint or stain, electrical.

CLARIFICATIONS: 1) All work to be completed during normal working hours and mutually agreed upon logical sequenced schedule.

TOTAL BID AMOUNT: We acknowledge addenda. Quote is good for 30 days. \$ 39,600.00

If no Galvanized product is need please DEDUCT \$ 2,200.00

Please contact me if any questions at 816-215-5250

Thank you for the opportunity to work with you.:

Juan J. Caman

Sincerely,
Juan Caman
Camán Construction Company Inc.

EQ-C13A-13ABCP

Electronic Faucets



a Geberit company

Architect/Engineer Specification

Chicago Faucets No. EQ-C13A-13ABCP, EQ High Arc Series Lavatory Sink Faucet with hands-free infrared detection, deck-mounted with 8" centers. Chrome plated. 0.5 GPM (1.9 L/min) vandal-proof, pressure compensating, Econo-Flo non-aerating spray outlet. Dual supply for hot and cold water service. Powered by 4 "AA" alkaline batteries (included) - up to 5-year battery life. Includes stainless steel braided hose(s). Includes concealed thermostatic mixing valve. On-demand IR detection for hands-free actuation and maximum water savings. 20 seconds standard maximum run time; drops to 10 seconds in high use environments for additional water savings. ECAST® construction with less than 0.25% lead content by weighted average. CALGreen compliant. This product meets ADA ANSI/ICC A117.1 requirements and is tested and certified to industry standards: ASME A112.18.1/CSA B125.1, Certified to NSF/ANSI 61, Section 9 by CSA, ASSE 1070, California Health and Safety Code 116875 (AB1953-2006), Vermont Bill S.152, NSF/ANSI 372 Low Lead Content, and California Green Building Standards Code (CALGreen).

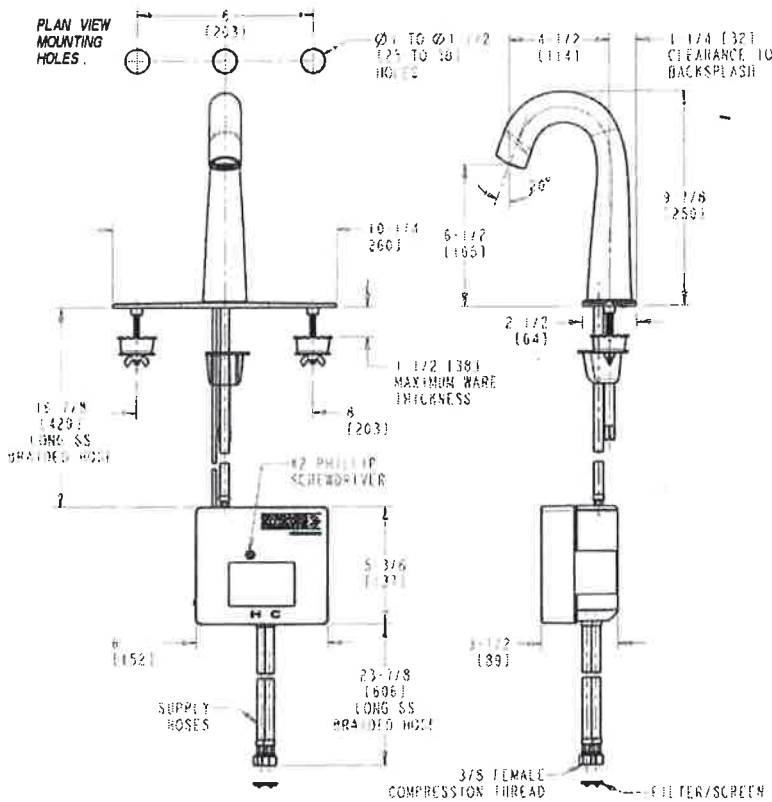

\$550 EA
ANIMAL SHELTER

Operation and Maintenance

Installation should be in accordance with local plumbing codes. Flush all pipes thoroughly before installation. After installation, remove spout outlet or flow control and flush faucet thoroughly to clear any debris. Care should be taken when cleaning the product. Do not use abrasive cleaners, chemicals or solvents as they can result in surface damage. Use mild soap and warm water for cleaning and protecting the life of Chicago Faucet products. For specific operation and maintenance refer to the installation instructions and repair parts documents that are located at www.chicagofaucets.com.

Chicago Faucets, member of the Geberit Group, is the leading brand of commercial faucets and fittings in the United States, offering a complete range of products for schools, laboratories, hospitals, office buildings, food service, airports and sport facilities. Call 1.800.TECTRUE or 1.847.803.5000 Option 1 for installation or other technical assistance.



2100 South Clearwater Drive
Des Plaines, IL
P: 847/803-5000
F: 847/803-5454
Technical: 800/TEC-TRUE
www.chicagofaucets.com